



3 BURNER CAMP STOVE WITH FOLDING SIDE TABLE

IMPORTANT, READ CAREFULLY, RETAIN FOR FUTURE
REFERENCE. MANUAL MUST BE READ BEFORE OPERATING!



TH3BCMP

58211

MANUAL

THIESSSENS.COM

**FOR OUTDOOR AND HOUSEHOLD USE ONLY. NOT FOR COMMERCIAL USE.
FUEL AND ACCESSORIES NOT INCLUDED.**

WARNING: PLEASE READ THE ENTIRE MANUAL BEFORE INSTALLATION AND USE OF THIS GAS APPLIANCE. FAILURE TO FOLLOW THESE INSTRUCTIONS COULD RESULT IN PROPERTY DAMAGE, BODILY INJURY OR EVEN DEATH. CONTACT LOCAL BUILDING OR FIRE OFFICIALS ABOUT RESTRICTIONS AND INSTALLATION INSPECTION REQUIREMENTS IN YOUR AREA.

MAJOR CAUSES OF APPLIANCE FIRES ARE A RESULT OF POOR MAINTENANCE AND A FAILURE TO MAINTAIN REQUIRED CLEARANCE TO COMBUSTIBLE MATERIALS. IT IS OF UTMOST IMPORTANCE THAT THIS PRODUCT BE USED ONLY IN ACCORDANCE WITH THE FOLLOWING INSTRUCTIONS.

PLEASE READ AND UNDERSTAND THIS ENTIRE MANUAL BEFORE ATTEMPTING TO ASSEMBLE, OPERATE OR INSTALL THE PRODUCT. THIS WILL ENSURE YOU RECEIVE THE MOST ENJOYABLE AND TROUBLE-FREE OPERATION OF YOUR NEW GAS CAMP STOVE. WE ALSO ADVISE YOU RETAIN THIS MANUAL FOR FUTURE REFERENCE.

PROPANE GAS WARNINGS

DANGER

IF YOU SMELL GAS:

- SHUT OFF GAS TO THE APPLIANCE.
- EXTINGUISH ANY OPEN FLAME.
- OPEN LID.
- IF ODOR CONTINUES, KEEP AWAY FROM THE APPLIANCE AND IMMEDIATELY CALL YOUR GAS SUPPLIER OR YOUR FIRE DEPARTMENT.

DANGER

NEVER OPERATE THIS APPLIANCE:

- UNATTENDED.
- WITHIN 3.0 M (10 FT) OF ANY STRUCTURE, COMBUSTIBLE MATERIAL OR OTHER GAS CYLINDER.
- WITHIN 7.5 M (25 FT) OF ANY FLAMMABLE LIQUID.

FAILURE TO FOLLOW THESE INSTRUCTIONS COULD RESULT IN FIRE OR EXPLOSION WHICH COULD CAUSE PROPERTY DAMAGE, PERSONAL INJURY OR DEATH.

1. ENSURE THE GAS CYLINDER IS PURCHASED BY A REPUTABLE SUPPLIER. AN INCORRECTLY FILLED OR AN OVERFILLED GAS CYLINDER CAN BE DANGEROUS. THE OVERFILLED CONDITION COMBINED WITH THE WARMING OF THE GAS CYLINDER (A HOT SUMMER DAY, GAS CYLINDER LEFT IN THE SUN, ETC.) CAN CAUSE LP GAS TO BE RELEASED SINCE THE TEMPERATURE INCREASE CAUSES GAS TO EXPAND. GAS RELEASED FROM THE CYLINDER IS FLAMMABLE AND CAN BE EXPLOSIVE.
2. DO NOT USE AN LP GAS CYLINDER IF IT HAS A DAMAGED VALVE OR SHOWS SIGNS OF DENTS, GOUGES, BULGES, FIRE DAMAGE, CORROSION, LEAKAGE, EXCESSIVE RUST, OR OTHER FORMS OF VISUAL EXTERNAL DAMAGE; IT MAY BE HAZARDOUS AND SHOULD BE CHECKED IMMEDIATELY BY A LIQUID PROPANE SUPPLIER.

IF YOU SEE, SMELL, OR HEAR THE HISS OF GAS ESCAPING FROM THE CYLINDER, DO NOT ATTEMPT TO LIGHT APPLIANCE. EXTINGUISH ANY OPEN FLAME. DISCONNECT FROM FUEL SUPPLY.

3. DO NOT CONNECT OR DISCONNECT THE GAS CYLINDER WHILE THE UNIT IS IN USE OR IS STILL HOT. WHEN CAMP STOVE IS NOT IN USE, ENSURE SUPPLY CYLINDER IS TURNED TO OFF AND DISCONNECT THE GAS CYLINDER. NEVER MOVE OR TRANSPORT THE UNIT WHILE THE GAS CYLINDER IS ATTACHED. DO NOT STORE A SPARE LP GAS CYLINDER UNDER OR NEAR THE APPLIANCE.
4. PARTS SEALED BY MANUFACTURER SHALL NOT BE MANIPULATED BY THE USER. DO NOT MOVE THE APPLIANCE DURING USE. TURN OFF THE GAS SUPPLY AT THE GAS CYLINDER AFTER USE. DO NOT MODIFY THE APPLIANCE. THE REPLACEMENT HOSE ASSEMBLY SHALL BE THAT SPECIFIED BY THE MANUFACTURER.
5. OPERATE THIS APPLIANCE USING LIQUEFIED PETROLEUM ONLY, WHICH IS ALSO SPECIFIED ON THE RATING LABEL ON THE UNIT. DO NOT ATTEMPT TO OPERATE YOUR CAMP STOVE ON OTHER GASES. DO NOT ATTEMPT TO CONVERT THIS LP UNIT TO NATURAL GAS. FAILURE TO FOLLOW THIS WARNING COULD LEAD TO FIRE, BODILY HARM, AND WILL VOID YOUR WARRANTY.
6. ALWAYS CHECK FOR GAS LEAKS WHEN YOU CONNECT AND DISCONNECT THE REGULATOR TO THE GAS CYLINDER, ESPECIALLY AFTER A PERIOD OF STORAGE (FOR EXAMPLE, OVER WINTER). CHECK ALL CONNECTIONS FOR LEAKS WITH A SOAPY WATER SOLUTION AND BRUSH. NEVER USE AN OPEN FLAME TO CHECK FOR LEAKS.

DANGERS AND WARNINGS

1. A MINIMUM CLEARANCE OF 3 M (10 FEET) FROM COMBUSTIBLE CONSTRUCTIONS TO ALL SIDES OF THE UNIT MUST BE MAINTAINED. DO NOT USE THIS APPLIANCE INDOORS OR IN AN ENCLOSED, UNVENTILATED AREA. THIS APPLIANCE MUST NOT BE PLACED UNDER OVERHEAD COMBUSTIBLE CEILING OR OVERHANG, INCLUDING ON OR UNDER ANY APARTMENT, OR CONDOMINIUM BALCONY OR DECK. USE THE BURNER ON A STABLE LEVELLED NON-COMBUSTIBLE SURFACE AND IN AN AREA CLEAR OF COMBUSTIBLE MATERIALS. AN ASPHALT SURFACE (BLACKTOP) MAY NOT BE ACCEPTABLE FOR THIS PURPOSE.

SHOULD A GREASE FIRE OCCUR, TURN THE CAMP STOVE OFF UNTIL THE FIRE IS OUT. DO NOT THROW WATER ON. DO NOT TRY TO SMOTHER THE FIRE. USE OF AN ALL-CLASS (CLASS ABC) APPROVED FIRE EXTINGUISHER IS VALUABLE TO KEEP ON SITE. IF AN UNCONTROLLED FIRE DOES OCCUR, CALL THE FIRE DEPARTMENT.

2. THIS OUTDOOR CAMP STOVE IS NOT INTENDED FOR INSTALLATION IN/ON RECREATION VEHICLES OR BOATS.

NEVER USE THIS APPLIANCE IN AN ENCLOSED SPACE, SUCH AS A CAMPER, TENT, CAR, BOAT OR HOME. THIS APPLIANCE IS NOT INTENDED FOR AND SHOULD NEVER BE USED AS A HEATER.

3. THIS APPLIANCE IS NOT RECOMMENDED FOR CHILDREN, PERSONS WITH REDUCED PHYSICAL, SENSORY OR MENTAL CAPABILITIES, OR LACK OF EXPERIENCE AND KNOWLEDGE, UNLESS THEY ARE UNDER DIRECT SUPERVISION OR INSTRUCTION BY A PERSON RESPONSIBLE FOR THEIR SAFETY. THE USE OF ALCOHOL, PRESCRIPTION, OR NON-PRESCRIPTION DRUGS MAY IMPAIR THE CONSUMER'S ABILITY TO PROPERLY ASSEMBLE OR SAFELY OPERATE THE APPLIANCE.
4. DO NOT PLACE AN EMPTY COOKING VESSEL ON THE APPLIANCE WHILE IN OPERATION. USE CAUTION WHEN PLACING ANYTHING IN COOKING VESSEL WHILE THE APPLIANCE IS IN OPERATION. NEVER USE A COOKING VESSEL LARGER THAN 220 MM / 8.66 INCHES.
5. PARTS OF THE CAMP STOVE MAY BE VERY HOT, AND SERIOUS INJURY MAY OCCUR. KEEP YOUNG CHILDREN AND PETS AWAY WHILE IN USE. DO NOT TOUCH HOT SURFACES. USE HEAT-RESISTANT GLOVES, LONG-HANDLED TONGS, OR COOKING MITTS AT ALL TIMES, SINCE THE CAMP STOVE WILL BECOME VERY HOT.
6. DO NOT OBSTRUCT THE FLOW OF COMBUSTION AND VENTILATION AIR TO THIS APPLIANCE. KEEP THE BURNER TUBE AND PORTHOLES CLEAN AND FREE FROM DEBRIS. CLEAN BEFORE USE. REGULAR CARE AND MAINTENANCE IS REQUIRED TO PROLONG THE LIFESPAN OF YOUR UNIT. KEEP THE FUEL SUPPLY HOSE AWAY FROM ANY HEATED SURFACE(S).
7. CLEAN AND INSPECT THE GAS REGULATOR BEFORE EACH USE OF THE OUTDOOR COOKING GAS APPLIANCE. REPLACE THE GAS REGULATOR PRIOR TO BEING USED IF THERE IS EVIDENCE OF EXCESSIVE ABRASION OR WEAR.

CARBON MONOXIDE

CARBON MONOXIDE IS A COLORLESS, ODORLESS, TASTELESS GAS PRODUCED BY BURNING GAS, WOOD, PROPANE, CHARCOAL OR ANY OTHER FUELS. CARBON MONOXIDE REDUCES THE BLOOD'S ABILITY TO CARRY OXYGEN. LOW BLOOD OXYGEN LEVELS CAN RESULT IN HEADACHES, DIZZINESS, WEAKNESS, NAUSEA, VOMITING, SLEEPINESS, CONFUSION, LOSS OF CONSCIOUSNESS OR DEATH. FOLLOW THESE GUIDELINES TO PREVENT THIS COLORLESS, ODORLESS GAS FROM POISONING YOU, YOUR FAMILY, OR OTHERS:

- SEE A DOCTOR IF YOU OR OTHERS DEVELOP COLD OR FLU-LIKE SYMPTOMS WHILE COOKING OR IN THE VICINITY OF THE APPLIANCE. CARBON MONOXIDE POISONING, WHICH CAN EASILY BE MISTAKEN FOR A COLD OR FLU, IS OFTEN DETECTED TOO LATE.
- ALCOHOL CONSUMPTION AND DRUG USE INCREASE THE EFFECTS OF CARBON MONOXIDE POISONING.

CARBON MONOXIDE IS ESPECIALLY TOXIC TO MOTHER AND CHILD DURING PREGNANCY, INFANTS, THE ELDERLY, SMOKERS, AND PEOPLE WITH BLOOD OR CIRCULATORY SYSTEM PROBLEMS, SUCH AS ANEMIA, OR HEART DISEASE.



SAFETY LISTING

CONFORMS TO ANS Z21.89-2017, CSA 1.18-2017, OUTDOOR COOKING GAS APPLIANCE. INSTALLATION MUST CONFORM WITH LOCAL CODES OR, IN THE ABSENCE OF LOCAL CODES, WITH THE NATIONAL FUEL GAS CODE, ANS Z223.1/NFPA 54, STORAGE AND HANDLING OF LIQUEFIED PETROLEUM GASES, ANS/NFPA 58; OR NATURAL GAS AND PROPANE INSTALLATION CODE, CSA 8149. 1; PROPANE STORAGE AND HANDLING, CSA 8149.2; OR THE STANDARD FOR RECREATIONAL VEHICLES, ANS A119.2/NFPA 1192, AND RECREATIONAL VEHICLE CODE, CSA Z240 RV SERIES, AS APPLICABLE.



COPYRIGHT NOTICE

COPYRIGHT 2021. ALL RIGHT RESERVED.
NO PART OF THIS MANUAL MAY BE
COPIED, TRANSMITTED, TRANSCRIBED,
STORED IN A RETRIEVAL SYSTEM, IN
ANY FORM OR BY ANY MEANS WITHOUT
EXPRESSED WRITTEN PERMISSION OF,

MANUFACTURED BY:
DANSONS, 3411 NORTH 5TH AVENUE,
SUITE 500, PHOENIX, AZ, USA 85013

CUSTOMER CARE
TOLL-FREE: 1-877-972-5742

TABLE OF CONTENTS

PROPANE GAS WARNINGS	2
DANGERS & WARNINGS.....	3
CARBON MONOXIDE	3
PARTS AND SPECS.....	5
ASSEMBLY PREPARATION	6
ASSEMBLY INSTRUCTIONS.....	6
GAS CYLINDER REQUIREMENTS.....	8
CONNECTING THE GAS CYLINDER.....	8
PREPARATION FOR USE - LEAK TESTING	9
DISCONNECTING THE GAS CYLINDER	9
AUTOMATIC LIGHTING PROCEDURE.....	10
MANUAL LIGHTING PROCEDURE	10
SHUTTING OFF YOUR UNIT	11
COLLAPSING FOR TRANSPORT	11
CARE AND MAINTENANCE.....	12
TROUBLESHOOTING.....	13
REPLACEMENT PARTS.....	14
WARRANTY	15

PARTS AND SPECS

MODEL	TH3BCMP
ASSEMBLED (L x W x H)	78.3 x 24.8 x 36.9 in. (199 x 63.2 x 93.8 cm)
WEIGHT	68.3 lb (31.0 kg)
COOKING AREA	486.2 in ² (3,136 cm ²)
BTU	90,000

PART	DESCRIPTION
1	Support Frame (x1)
2	Bracket A (x1)
3	Bracket B (x1)
4	Side Table (x1)
5	Side Table Bracket (x1)
6	Stove Body (x1)
A	Screw (x12)
B	Step Screw (x2)

NOTE: Due to ongoing product development, parts are subject to change without notice. Contact Customer care if parts are missing when assembling the unit.

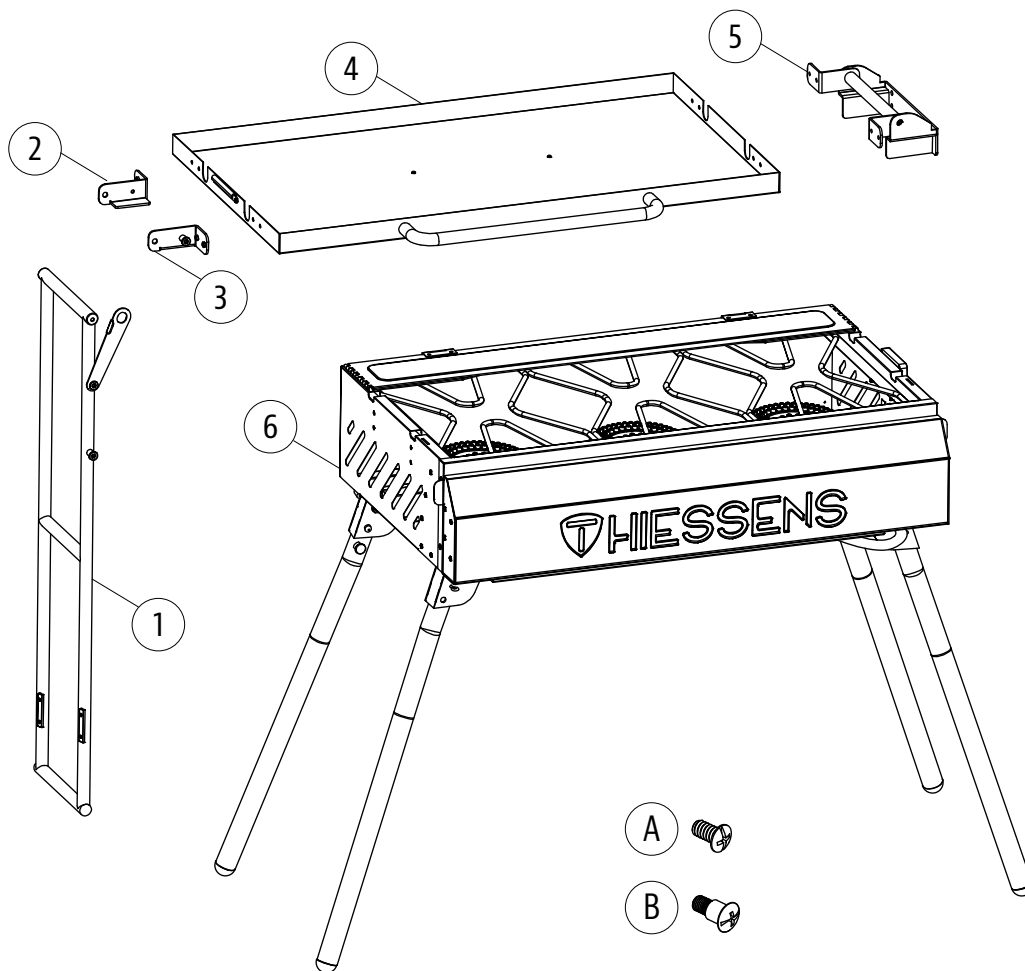

ASSEMBLY PREPARATION

PARTS ARE LOCATED THROUGHOUT THE SHIPPING CARTON. INSPECT THE UNIT, PARTS, AND HARDWARE AFTER REMOVING FROM THE PROTECTIVE SHIPPING CARTON. DISCARD ALL PACKAGING MATERIALS FROM INSIDE AND OUTSIDE OF THE UNIT BEFORE ASSEMBLY, THEN REVIEW AND INSPECT ALL PARTS BY REFERENCING THE PARTS LIST. IF ANY PART IS MISSING OR DAMAGED, DO NOT ATTEMPT TO ASSEMBLE. SHIPPING DAMAGE IS NOT COVERED UNDER WARRANTY. CONTACT CUSTOMER CARE FOR PARTS: MONDAY THROUGH SUNDAY, 4 A.M. – 8 P.M. PST (EN/FR/ES).

- TOOLS REQUIRED FOR ASSEMBLY: PHILLIPS SCREWDRIVER. TOOLS NOT INCLUDED.

TO EASE INSTALLATION, USING TWO PEOPLE IS HELPFUL (BUT NOT NECESSARY) WHEN ASSEMBLING THIS UNIT.

ASSEMBLY INSTRUCTIONS

PLACE A PIECE OF CARDBOARD ON THE FLOOR TO PREVENT SCRATCHING THE UNIT AND PARTS DURING ASSEMBLY.

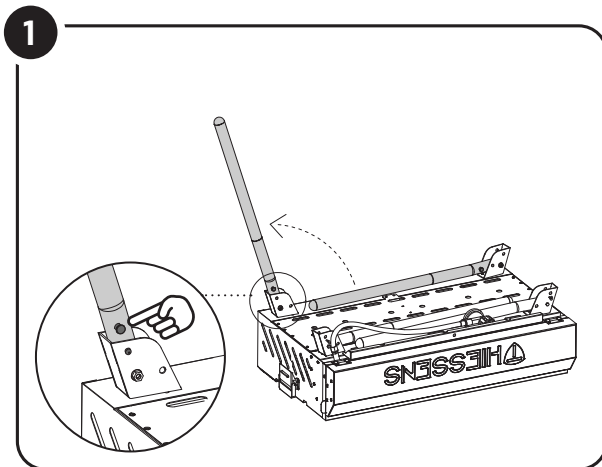

Turn over the Stove Body so it lies flat-side down on the cardboard. Push down the Locking Pin to release each Support Leg. Extend each of the four Support Legs until the Locking Pins lock at full extension.

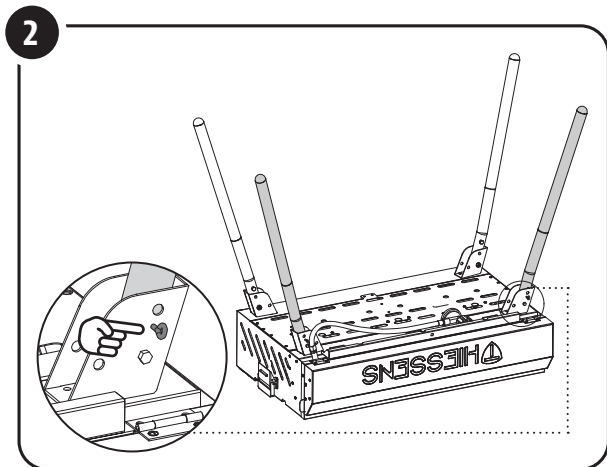

On the front Support Legs only, tighten the Support Leg fixing screws to lock all Support Legs in place.

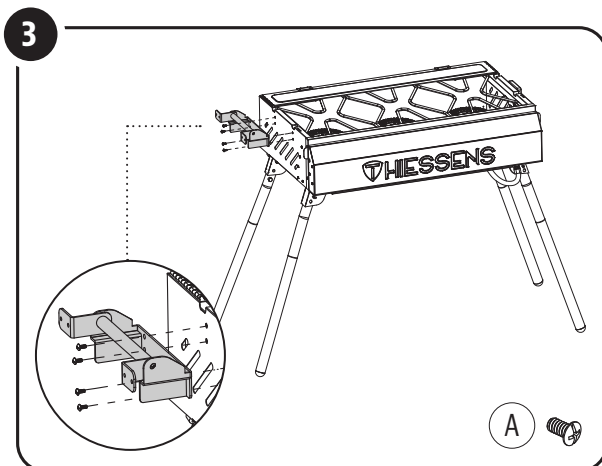

Turn over the Stove Body so it stands on the Support Legs. Install Bracket A and Bracket B to the left side of the Stove Body using four screws, as shown.

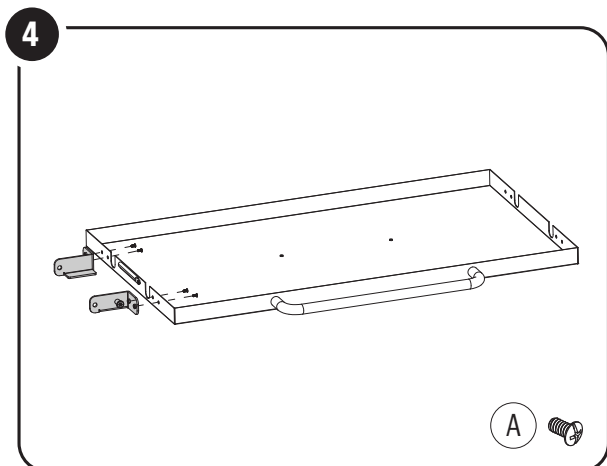

Mount Bracket A and Bracket B to the left side of the Side Table (handle faces the front) using two screws in each Bracket, as shown.

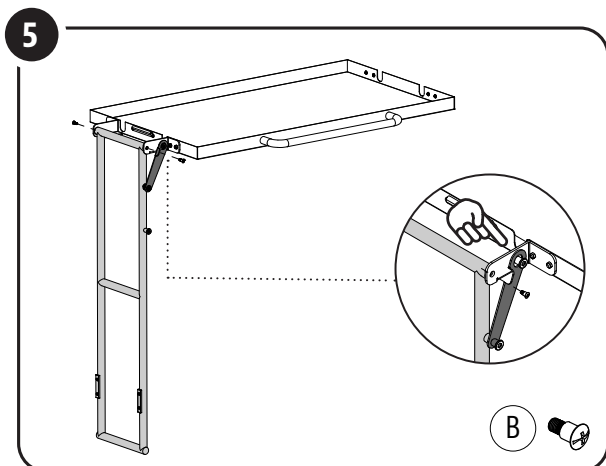

Fasten the Support Frame to the Side Table using two step screws. To secure the Support Frame in expanded position, swing the Locking Plate onto the Locking Pin.

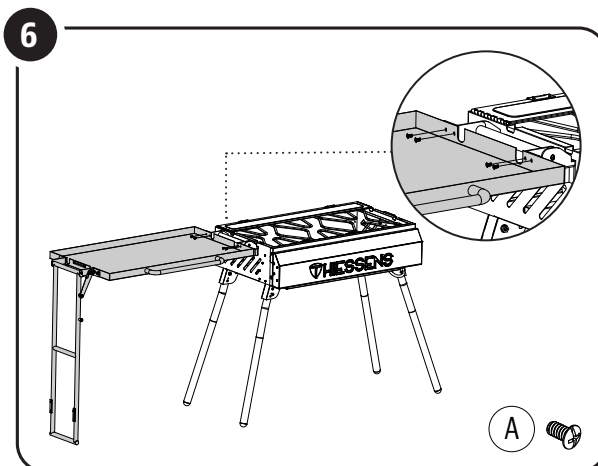

Fasten the Side Table to the Stove Body using four screws.

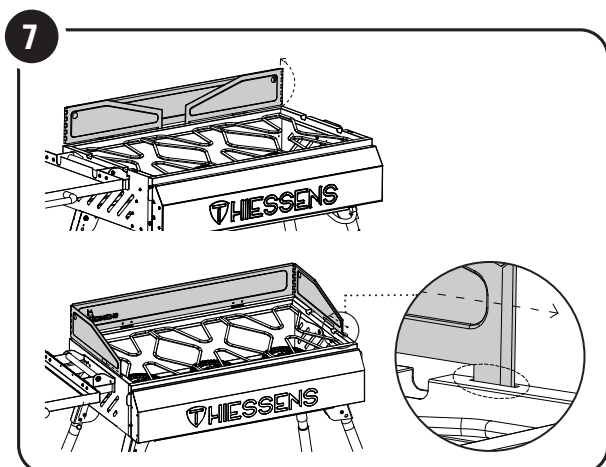

Lift the Wind Shield upright and expand the Wind Shield Side Wings. Place the tabs of the Wind Shield Side Wings into the small tab openings near the front two corners of the Stove Body top.

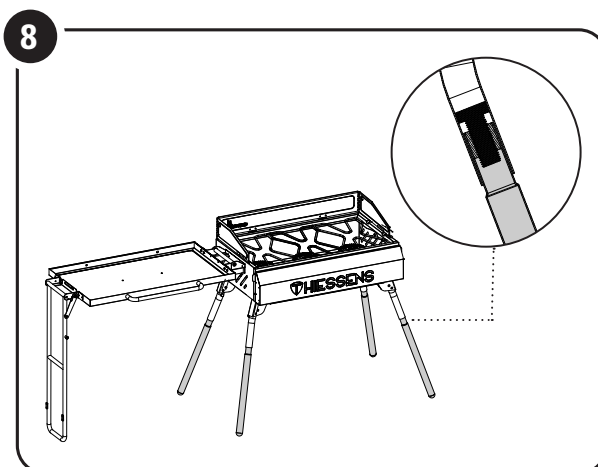

If ground is uneven, rotate the bottom half of each Support Leg to adjust the height. Adjustment variant is up to 1.5 inches / 38 mm. Assembly of unit is now complete.

GAS CYLINDER REQUIREMENTS

THE CAMP STOVE IS SET AND TESTED WITH LIQUID PROPANE (LP) GAS ONLY. THE REGULATOR SUPPLIED IS SET FOR 27.94 CM (11 INCH) WATER COLUMN (WC) AND IS FOR USE WITH LP GAS ONLY. THE FACTORY-SUPPLIED REGULATOR AND HOSE MUST BE USED WITH A 9 KG (20 LB) LP GAS TANK. CONTACT YOUR GAS SUPPLIER FOR A SPECIAL REGULATOR FOR BULK GAS THAT FUELS OTHER APPLIANCES.

CAUTION: IT IS IMPORTANT TO INSPECT THE FULL LENGTH OF THE GAS LINE HOSE. IF IT IS EVIDENT THERE IS EXCESSIVE ABRASION OR WEAR, OR THE HOSE IS CUT, THE HOSE MUST BE REPLACED PRIOR TO THE APPLIANCE BEING USED.

THE LP-GAS SUPPLY CYLINDER TO BE USED MUST BE CONSTRUCTED AND MARKED IN ACCORDANCE WITH THE SPECIFICATIONS FOR LP-GAS CYLINDERS, U.S. DEPARTMENT OF TRANSPORTATION (DOT) OR THE STANDARD FOR CYLINDERS, SPHERES AND TUBES FOR THE TRANSPORTATION OF DANGEROUS GOODS, CAN/CSA-B339. CYLINDER SYSTEM MUST BE ARRANGED FOR VAPOR WITHDRAWAL.

1. DO NOT STORE A SPARE LP GAS CYLINDER UNDER OR NEAR THIS APPLIANCE.
2. NEVER FILL THE GAS CYLINDER BEYOND 80 PERCENT FULL.
3. IF THE INFORMATION IN 1) AND 2) IS NOT FOLLOWED EXACTLY A FIRE CAUSING DEATH OR SERIOUS INJURY MAY OCCUR.
4. PLACE DUST CAP ON CYLINDER VALVE OUTLET WHENEVER THE CYLINDER IS NOT IN USE. ONLY INSTALL THE TYPE OF DUST CAP ON THE CYLINDER VALVE OUTLET THAT IS PROVIDED WITH THE CYLINDER VALVE. OTHER TYPES OF CAPS OR PLUGS MAY RESULT IN LEAKAGE OF PROPANE.
5. THE LP GAS CYLINDER USED MUST HAVE A COLLAR TO PROTECT THE GAS CYLINDER VALVE.
6. ALWAYS KEEP THE LP CYLINDER AT 90 DEGREES (UPRIGHT) ORIENTATION TO PROVIDE VAPOR WITHDRAWAL.

NOTE: THE NORMAL FLOW OF GAS THROUGH THE REGULATOR AND HOSE ASSEMBLY CAN CREATE A HUMMING NOISE. A LOW VOLUME OF NOISE IS PERFECTLY NORMAL AND WILL NOT INTERFERE WITH OPERATION OF THE CAMP STOVE. IF HUMMING NOISE IS LOUD AND EXCESSIVE YOU MAY NEED TO PURGE AIR FROM THE GAS LINE OR RESET THE REGULATOR EXCESS GAS FLOW DEVICE. THIS PURGING PROCEDURE SHOULD BE DONE EVERY TIME A NEW LP GAS TANK IS CONNECTED TO YOUR CAMP STOVE.

CONNECTING THE GAS CYLINDER

IMPORTANT: IF THE MANIFOLD REQUIRES A CONNECTOR, FOLLOW THE CONNECTOR INSTALLATION INSTRUCTIONS PRIOR TO CONNECTING THE UNIT TO A GAS CYLINDER.

1. BEFORE CONNECTING, ENSURE THERE IS NO DEBRIS CAUGHT IN THE HEAD OF THE LP GAS CYLINDER, HEAD OF THE REGULATOR VALVE, OR IN THE HEAD OF THE BURNER AND BURNER PORTS.
2. CONNECT THE TUBE LINE TO THE MANIFOLD BY TURNING THE KNOB CLOCKWISE UNTIL IT STOPS. MAKE SURE THAT THE TUBE IS NOT TWISTED IN ANY WAY.
3. PLACE A GAS CYLINDER NEXT TO THE CAMP STOVE ON THE RIGHT SIDE. MAKE SURE THE GAS CYLINDER VALVE IS IN THE CLOSED POSITION. IT IS IMPORTANT TO ENSURE THE GAS CYLINDER IS COMPLETELY UPRIGHT, AS IT IS UNSAFE TO OPERATE THE CAMP STOVE IF THE GAS CYLINDER IS NOT PROPERLY LEVEL OR ON A STABLE SURFACE.
4. ENSURE THE CONTROL KNOBS ON THE CAMP STOVE ARE COMPLETELY CLOSED BY TURNING THE KNOB CLOCKWISE TO THE "OFF" POSITION.
5. REMOVE THE PROTECTIVE CAPS FROM THE REGULATOR VALVE OPENING AND THE TOP OF THE GAS CYLINDER. SAVE THE CAPS.
6. INSERT THE GAS CYLINDER VALVE INTO THE THREADED OPENING OF THE REGULATOR VALVE. TURN THE QUICK COUPLING NUT CLOCKWISE UNTIL FIRM. HAND-TIGHTEN ONLY.
7. GAS CYLINDER IS NOW INSTALLED. PERFORM A LEAK TEST.

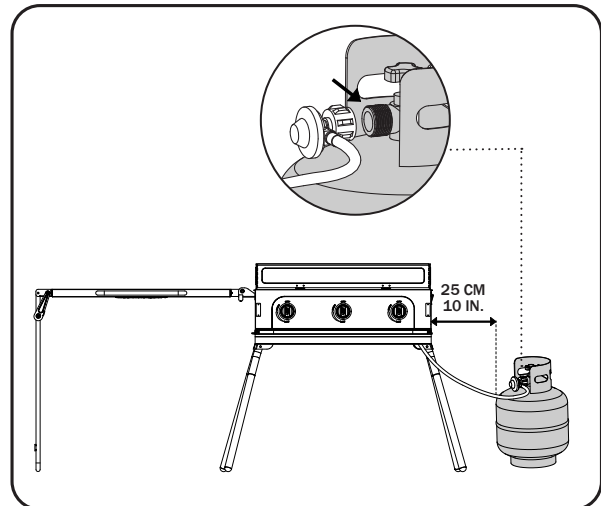

WARNING: SHUT OFF THE GAS CYLINDER IF YOU SMELL GAS. ATTEMPT TO RE-INSTALL THE GAS CYLINDER TO ENSURE THAT TUBE IS CONNECTED PROPERLY. PERFORM A LEAK TEST.

NOTE: THE NORMAL FLOW OF GAS THROUGH THE REGULATOR AND HOSE ASSEMBLY CAN CREATE A HUMMING NOISE. A LOW VOLUME OF NOISE IS PERFECTLY NORMAL AND WILL NOT INTERFERE WITH OPERATION OF THE CAMP STOVE. IF HUMMING NOISE IS LOUD AND EXCESSIVE YOU MAY NEED TO PURGE AIR FROM THE GAS LINE OR RESET THE REGULATOR EXCESS GAS FLOW DEVICE. THIS PURGING PROCEDURE SHOULD BE DONE EVERY TIME A NEW GAS CYLINDER IS CONNECTED TO YOUR CAMP STOVE.

PREPARATION FOR USE – LEAK TESTING

A LEAK TEST IS USED TO DETERMINE THE INTEGRITY OF A SEAL. BEFORE USING YOUR CAMP STOVE, PERFORM A LEAK TEST ON THE CONNECTION BETWEEN THE REGULATOR AND THE GAS CYLINDER TO REDUCE THE RISK OF SERIOUS BODILY INJURY OR DEATH FROM FIRE OR EXPLOSION. A LEAK TEST SHOULD BE PERFORMED A MINIMUM OF ONCE A SEASON, AS WELL AS:

- BEFORE LIGHTING YOUR CAMP STOVE FOR THE FIRST TIME,
- EVERY TIME THE GAS CYLINDER HAS BEEN CHANGED,
- AFTER TRAVEL, ESPECIALLY OVER ROUGH OR BUMPY ROADS,
- AFTER A PROLONGED PERIOD OF STORAGE OR NON-USE.

HOW TO PERFORM A LEAK TEST

BEFORE YOU USE THE BURNER FOR THE FIRST TIME, AND ALSO PERIODICALLY, CHECK THE WHOLE SYSTEM FOR LEAKS FOLLOWING THE PROCEDURE LISTED BELOW. ALTERNATIVELY, IF THE SMELL OF GAS IS DETECTED AT ANYTIME DURING USE OF THE UNIT, TURN OFF GAS SUPPLY AND IMMEDIATELY CHECK THE ENTIRE SYSTEM FOR LEAKS.

LEAK TEST PROCEDURE

1. PREPARE A SOAPY SOLUTION IN A 30/70% PROPORTION OF DISH LIQUID DETERGENT AND WATER.
2. MAKE SURE ALL CONTROL KNOBS ARE AT THE OFF POSITION.
3. OPEN GAS CYLINDER VALVE.
4. USING A SPRAY BOTTLE OR APPLICATOR BRUSH, APPLY THE SOLUTION TO THE FITTINGS, ALL CONNECTIONS AND GAS HOSES. FOR THE INITIAL LEAK TEST, MAKE SURE THE LP CYLINDER IS FULL.
5. FORMATION OF BUBBLES INDICATE A LEAK. IF A LEAK IS IDENTIFIED, CLOSE GAS CYLINDER VALVE, RE-TIGHTEN LOOSE FITTINGS AND TEST AGAIN. IF LEAK PERSISTS OR REQUIRES REPLACEMENT OF A PART, CONTACT YOUR RESELLER OR A QUALIFIED GAS TECHNICIAN.

ONLY THOSE PARTS RECOMMENDED BY THE MANUFACTURER SHOULD BE USED ON THIS APPLIANCE. SUBSTITUTION WILL VOID THE WARRANTY. DO NOT USE THIS APPLIANCE UNTIL ALL CONNECTIONS HAVE BEEN CHECKED AND DO NOT LEAK.

DISCONNECTING THE GAS CYLINDER

1. TURN ALL CONTROL KNOBS TO "OFF" POSITION ON THE CAMP STOVE. ENSURE THE REGULATOR VALVE ON THE GAS CYLINDER IS COMPLETELY CLOSED BY TURNING THE KNOB TO THE CLOSED POSITION.
2. TURN THE QUICK COUPLING NUT COUNTER-CLOCKWISE (BY HAND) TO DISCONNECT FROM THE REGULATOR VALVE OPENING. REPLACE THE PROTECTIVE CAPS ON THE REGULATOR VALVE OPENING AND THE TOP OF THE GAS CYLINDER FOR STORAGE (IF NOT EMPTY).

WARNING: IF STORING THE UNIT INDOORS, LEAVE THE GAS CYLINDER OUTDOORS. DO NOT FOLD UP OR TRANSPORT UNIT WITH GAS CYLINDER ATTACHED. THE CYLINDER MAY LOOSEN OFF THE VALVE AND CAUSE A GAS LEAK, POSSIBLY RESULTING IN AN EXPLOSION, FIRE, OR SEVERE BODILY HARM. DISCONNECT GAS CYLINDER FIRST BEFORE TRAVEL OR STORAGE.

AUTOMATIC LIGHTING PROCEDURE

WITH ALL OUTDOOR APPLIANCES, OUTSIDE WEATHER CONDITIONS PLAY A BIG PART IN THE PERFORMANCE OF YOUR UNIT AND THE COOKING TIME NEEDED TO PREPARE YOUR MEALS. ALL THIESSENS UNITS SHOULD KEEP A MINIMUM CLEARANCE OF 3 M (10 FEET) FROM COMBUSTIBLE CONSTRUCTIONS, AND THIS CLEARANCE MUST BE MAINTAINED WHILE THE UNIT IS OPERATIONAL. THIS APPLIANCE MUST NOT BE PLACED UNDER OVERHEAD COMBUSTIBLE CEILING OR OVERHANG. KEEP YOUR UNIT IN AN AREA CLEAR FROM COMBUSTIBLE MATERIALS, OR OTHER FLAMMABLE VAPORS AND LIQUIDS.

1. OPEN WIND SHIELD PANELS DURING LIGHTING.
2. SET ALL CONTROL KNOBS TO THE "OFF" POSITION.
3. OPEN THE CYLINDER/GAS VALVE ACCORDING TO THE OPERATING INSTRUCTIONS ON TANK.
4. PUSH IN THE REGULATOR KNOB AND TURN COUNTER-CLOCKWISE TO HIGH UNTIL YOU HEAR A "CLICK" SOUND TO INDICATE A SPARK FROM THE IGNITER, AND LOOK FOR FLAME TO ENSURE THE BURNER IS LIT.
5. AFTER THE BURNER HAS CAUGHT FIRE, YOU ARE READY TO ENJOY YOUR CAMP STOVE AT YOUR DESIRED TEMPERATURE!

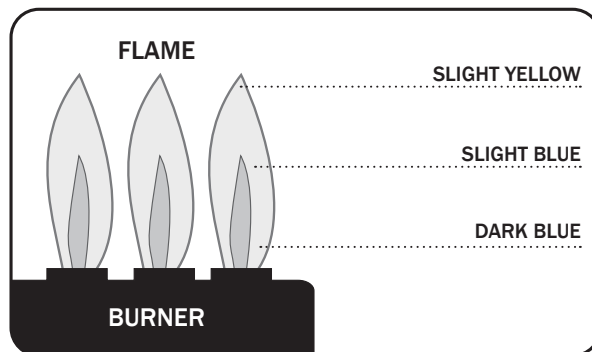

NOTE: DO NOT USE SPIRIT, LIGHTER-FLUID OR KEROSENE FOR LIGHTING.

6. IF THE BURNER DOES NOT LIGHT WITHIN 5 SECONDS, TURN BURNER CONTROL KNOB TO "OFF", WAIT 5 MINUTES, AND REPEAT LIGHTING INSTRUCTION. AFTER LIGHTING, OBSERVE THE BURNER FLAME. MAKE SURE ALL BURNER PORTS ARE LIT AND FLAME HEIGHT MATCHES ILLUSTRATION SHOWN ABOVE.

WARNING: NEVER LEAN OVER THE COOKING AREA WHILE LIGHTING YOUR CAMP STOVE. KEEP YOUR FACE AND BODY A SAFE DISTANCE (AT LEAST 18 INCHES / 457 MM) FROM THE COOKING SURFACE WHEN LIGHTING YOUR STOVE BY MATCH.

7. IF THE ABOVE POINTS DO NOT WORK, SEE MANUAL LIGHTING PROCEDURE.

MANUAL LIGHTING PROCEDURE

1. OPEN WIND SHIELD PANELS DURING LIGHTING.
2. SET ALL CONTROL KNOBS TO THE "OFF" POSITION.
3. OPEN THE CYLINDER/GAS VALVE ACCORDING TO THE OPERATING INSTRUCTIONS ON TANK.
4. QUICKLY AND CAREFULLY, USE A LONG MATCH OR LONG-NOSED LIGHTER TO LIGHT THE BURNER. POSITION LIT MATCH NEAR THE SIDE OF THE BURNER.

CAUTION: DO NOT ATTEMPT TO LIGHT ANOTHER AREA OF THE BURNER. THIS CAN CAUSE INJURY.

5. PUSH AND TURN THE BURNER CONTROL KNOB COUNTER-CLOCKWISE TO HIGH, HOLD THIS KNOB IN FOR 10 SECONDS AFTER THE BURNER IS LIT. YOU WILL HEAR THE "SNAPPING" SOUND OF THE SPARK UNTIL AFTER THE KNOB IS RELEASED.
6. REPEAT SAME STEPS FOR OTHER BURNERS, AS EACH BURNER LIGHTS INDEPENDENTLY.

NOTE: DO NOT USE SPIRIT, LIGHTER-FLUID OR KEROSENE FOR LIGHTING.

7. IF THE BURNER DOES NOT LIGHT WITHIN 5 SECONDS, TURN BURNER CONTROL KNOB TO "O", WAIT 5 MINUTES, AND REPEAT LIGHTING INSTRUCTION. AFTER LIGHTING, OBSERVE THE BURNER FLAME. MAKE SURE ALL BURNER PORTS ARE LIT AND FLAME HEIGHT MATCHES ILLUSTRATION SHOWN PREVIOUSLY.

WARNING: NEVER LEAN OVER THE COOKING AREA WHILE LIGHTING YOUR CAMP STOVE. KEEP YOUR FACE AND BODY A SAFE DISTANCE (AT LEAST 18 INCHES / 457 MM) FROM THE COOKING SURFACE WHEN LIGHTING YOUR STOVE BY MATCH.

8. IF THE BURNER GOES OUT DURING OPERATION, TURN THE CONTROL KNOBS TO THE "OFF" POSITION. WAIT FIVE MINUTES BEFORE ATTEMPTING TO RELIGHT TO ALLOW ANY ACCUMULATED GAS TO DISSIPATE. IF THE BURNER DOES NOT LIGHT OR IF THE ABOVE POINTS DO NOT WORK, SEE TROUBLESHOOTING.

SHUTTING OFF YOUR UNIT

1. WHEN FINISHED COOKING, TURN GAS CYLINDER VALVE TO THE CLOSED POSITION, AND ALLOW THE REGULATOR KNOB TO POP OUT. THIS SAFETY FEATURE LOCKS THE REGULATOR KNOB TO ENSURE THAT THE GAS IS NO LONGER FLOWING.
2. TURN CONTROL KNOBS TO THE "OFF" POSITION.

NOTE: A "POOF" SOUND IS NORMAL AS THE LAST OF THE LP GAS IS BURNED.

3. DISCONNECT GAS SUPPLY BY FOLLOWING THE DISCONNECT A GAS CYLINDER INSTRUCTIONS.

WARNING: ALLOW THE STOVE TO COOL COMPLETELY, AND REMOVE THE GAS CYLINDER, BEFORE MOVING, TRAVEL, OR FOR STORAGE.

COLLAPSING FOR TRANSPORT

YOUR STOVE CAN QUICKLY AND EASILY BE COLLAPSED FOR STORAGE AND EASY TRANSPORTATION. TO FOLD AND SECURELY TRANSPORT YOUR STOVE, SIMPLY FOLLOW THE BELOW INSTRUCTIONS.

IMPORTANT: ALWAYS ENSURE THE STOVE IS COMPLETELY COOLED, DISCONNECTED FROM A GAS SUPPLY, AND THAT ALL ACCESSORIES ARE REMOVED FROM THE STOVETOP AND SIDE TABLE SURFACES.

1. FOLD IN THE WIND SHIELD SIDE WINGS, THEN FOLD DOWN ALL WIND SHIELD PANELS SO THEY ARE FLAT ON THE STOVETOP.
2. HOLDING THE SIDE TABLE WITH ONE HAND, UNHOOK THE LOCKING PLATE FROM THE LOCKIN PIN ON THE SUPPORT FRAME. SWING THE SUPPORT FRAME OUTWARD, THEN LAY FLAT ONTO THE SIDE TABLE.
3. FLIP THE SIDE TABLE/SUPPORT FRAME OVER AND ONTO THE STOVE TOP, AND FASTEN THE BRACKET WITH THE DRAW LATCH. THE BRACKET IS SECURE ONCE THE SAFETY CATCH OF THE DRAW LATCH IS LOCKED. THE SAFETY CATCH PREVENTS THE DRAW LATCH FROM OPENING.
4. FOLD IN THE FRONT COVER.

NOTE: THE FRONT COVER WILL ONLY CLOSE IF THE BURNER CONTROL KNOBS ARE IN THE "OFF" POSITION.

5. CAREFULLY, TIP AND PLACE THE CAMP STOVE ON ITS SIDE (HORIZONTAL) TO FOLD IN THE SUPPORT LEGS. PUSH DOWN ON THE LOCKING PIN TO RELEASE EACH SUPPORT LEG. FOLD IN EACH OF THE FOUR SUPPORT LEGS UNTIL THE LOCKING PINS LOCK.
6. MOVE THE CAMP STOVE TO DESIRED LOCATION, OR TO VEHICLE FOR TRANSPORT, IMMEDIATELY TO AVOID INJURY TO YOURSELF OR DAMAGE TO THE UNIT.

IMPORTANT: TAKE SPECIAL CARE OF THE REGULATOR AND HOISING AS YOU COLLAPSE AND TRANSPORT THIS UNIT.

CARE AND MAINTENANCE

CHECKING THE GAS LEVEL

- TO CHECK THE AMOUNT OF FUEL IN A GAS CYLINDER, THE CAMP STOVE MUST BE IN OPERATION. PLACE YOUR HAND AT THE TOP OF THE GAS CYLINDER AND SLOWLY MOVE DOWN THE SIDE UNTIL THE GAS CYLINDER FEELS COOL TO THE TOUCH. THIS WILL INDICATE THE APPROXIMATE AMOUNT OF GAS IN YOUR GAS CYLINDER; IF $\frac{3}{4}$ EMPTY, REPLACE WITH A FULL GAS CYLINDER.

IMPORTANT: DO NOT USE CHARCOAL BRIQUETTES OR ANY FLAMMABLE MATERIAL WITH YOUR CAMP STOVE. USE OF SUCH MATERIAL WILL VOID YOUR WARRANTY AND MAY LEAD TO A FIRE, EXPLOSION AND BODILY HARM.

BURNER COMPONENTS

- CLEAN THE BURNER WHENEVER HEAVY BUILD-UP IS FOUND, TO ENSURE THAT THERE ARE NO SIGNS OF BLOCKAGE (DEBRIS, INSECTS) ON THE BURNER TUBE OR IN THE BURNER PORTHOLES. AFTER PERIODS OF STORAGE, SPIDERS OR SMALL INSECTS CAN BUILD NESTS, WEBS, AND LAY EGGS IN THE BURNER TUBE, OBSTRUCTING THE FLOW OF GAS TO THE BURNER. A CLOGGED TUBE CAN LEAD TO A FIRE BENEATH THE APPLIANCE. IF STORING THE CAMP STOVE, OR BEFORE AN EXTENDED PERIOD OF NON-USE, REMOVE THE BURNER AND WRAP WITH ALUMINUM FOIL TO REDUCE THE RISK OF INSECTS ENTERING THE BURNER HOLES.
- THE BURNER HAS BEEN PRESET FOR OPTIMAL FLAME PERFORMANCE. A BLUE FLAME, POSSIBLY WITH A SMALL YELLOW TIP, IS THE RESULT OF THE OPTIMAL AIR AND GAS MIXTURE. IF FLAMES ARE EXCESSIVELY YELLOW, ORANGE OR IRREGULAR, CLEAN THE OIL AND FOOD DEPOSITS ON THE BURNER SURFACE AND THE BURNER PORTHOLES TO INCREASE AIRFLOW.
- IF THE BURNER IS REMOVED DURING CLEANING OR MAINTENANCE, ENSURE THAT BURNER IS REPLACED IN THE PROPER POSITION WITH THE BURNER PORTHOLES FACING UPWARD. NOTE ILLUSTRATION SHOWN. WRONG PLACEMENT WILL LEAD TO FIRE, EXPLOSION AND BODILY HARM.

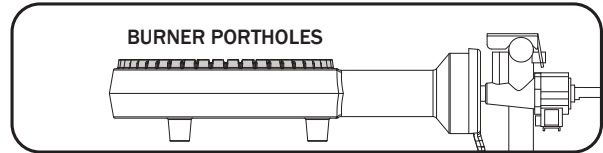

STOVE EXTERIOR & SIDE TABLE

- USE A COVER TO PROTECT YOUR CAMP STOVE FOR COMPLETE PROTECTION! A COVER IS YOUR BEST PROTECTION AGAINST WEATHER AND OUTSIDE POLLUTANTS. WHEN NOT IN USE OR FOR LONG-TERM STORAGE, KEEP THE UNIT UNDER A COVER IN A GARAGE OR SHED, WITH THE GAS CYLINDER REMOVED (CYLINDERS MUST BE STORED OUTDOORS).

CLEANING TIME TABLE (NORMAL USE)

COMPONENT PART	CLEANING FREQUENCY	CLEANING METHOD
BURNER TUBE, PORTHOLES	EVERY 5-6 USES	DUST, SCRUB PAD & SOAPY WATER
BURNERS	EVERY 5-6 USES	SCRUB PAD & SOAPY WATER
SIDE TABLE, SUPPORT FRAME, SUPPORT LEGS	AS NEEDED	NON-ABRASIVE CLOTH & SOAPY WATER

TROUBLESHOOTING

PROPER CLEANING AND MAINTENANCE WILL PREVENT COMMON OPERATIONAL PROBLEMS. WHEN YOUR CAMP STOVE IS OPERATING POORLY, OR ON A LESS FREQUENT BASIS, THE FOLLOWING TROUBLESHOOTING TIPS MAY BE HELPFUL.

WARNING: ALWAYS ENSURE THE STOVE IS COMPLETELY COOLED TO AVOID INJURY.

PROBLEM	CAUSE	SOLUTION
BURNER WILL NOT LIGHT	THE IGNITION WIRE IS BROKEN	CONTACT Customer care FOR ASSISTANCE OR A REPLACEMENT PART.
	NO IGNITER SPARK ON ELECTRODE	ADJUST THE ELECTRODE. CONTACT Customer care FOR ASSISTANCE OR A REPLACEMENT PART.
	NO GAS SUPPLIED	CHECK THE REGULATOR VALVE. CHECK CONNECTION FOR LEAK.
GREASE FIRE / FREQUENT FLARE-UPS	GRILLING FATTY MEATS	GRILL FATTY MEATS WHEN THE COOKING SURFACE IS COLD, AND THE KNOBS ARE ON THE "LOW" SETTING.
	COOKING TEMPERATURE	ATTEMPT COOKING AT A LOWER TEMPERATURE. GREASE DOES HAVE A FLASH POINT. KEEP THE TEMPERATURE UNDER 176°C / 350°F WHEN COOKING HIGHLY GREASY FOOD.
	WATER SPRAYED ON GAS FLAMES	DO NOT SPRAY WATER ON GAS FLAMES.
BURNER BLOWS OUT	NO GAS FLOW	CHECK GAS FUEL CONNECTION, AND ENSURE IT IS OPEN. REPLACE GAS CYLINDER IF EMPTY.
	GUSTING OR HIGH WINDS	TURN FRONT OF CAMP STOVE AWAY FROM WIND OR INCREASE FLAME HEIGHT.
LOW HEAT ON "HIGH"	PORTS BLOCKED	CLEAR PORTS OF ANY OBSTRUCTIONS.
	GAS CYLINDER EMPTY	REFILL THE GAS CYLINDER.
GAS LEAKAGE	IMPROPER INSTALLATION	TURN THE REGULATOR KNOB TO THE OFF POSITION, AND ALLOW THE REGULATOR KNOB TO POP OUT. REMOVE THE GAS CYLINDER. RE-INSTALL AND TIGHTEN. PERFORM LEAK TEST TO ENSURE PROPER SEAL. REPLACE GAS CYLINDER IF DAMAGED.
	SEAL FAILURE	GAS CYLINDER HAS CORRODED, RUSTED, OR HAS BEEN MISHANDLED. REPLACE GAS CYLINDER.
	REGULATOR FAILURE	REGULATOR NEEDS TO BE REPLACED. CONTACT Customer care FOR A REPLACEMENT PART.
BURNER FLAMES ARE YELLOW OR ORANGE	POOR AIR FLOW	CHECK BURNER TUBE AND BURNER PORTS FOR SPIDER WEBS OR OTHER OBSTRUCTIONS. FOLLOW CARE AND MAINTENANCE INSTRUCTIONS TO CLEAN THE BURNER TUBE.
	BURNER OBSTRUCTION	
	GREASE CUP IS FULL, SPILLING	EMPTY GREASE CUP AND RE-INSTALL. FOLLOW CARE AND MAINTENANCE INSTRUCTIONS.
	REGULATOR VALVE IS OFF	CHECK THE REGULATOR VALVE CONNECTION TO THE GAS CYLINDER. REMOVE, THEN REINSTALL. PERFORM LEAK TEST.
	BURNER IS DIRTY	TURN REGULATOR KNOB TO HIGH FOR FIVE MINUTES, AND BURN-OFF THE UNIT. FOLLOW CARE AND MAINTENANCE INSTRUCTIONS.

REPLACEMENT PARTS

PART	DESCRIPTION
1	Support Frame B (x1)
2	Bracket A (x1)
3	Bracket B (x1)
4	Side Table (x1)
5	Side Table Handle (x1)
6	Side Table Bracket (x1)
7	Wind Shield Assembly (x1)
8	Stove Firebox (x1)
9	Clasp (x1)
10	Fixed Leg (x4)
11	Adjustable Leg (x4)
12	Burner (x3)
13	Air Handle (x3)
14	Valve Assembly (x1)
15	Regulator With Hose (x1)
16	Control Panel (x1)
17	Control Knob Bezel (x3)
18	Control Knob (x3)
19	Front Cover (x1)
A	Screw (x12)
B	Step Screw (x2)

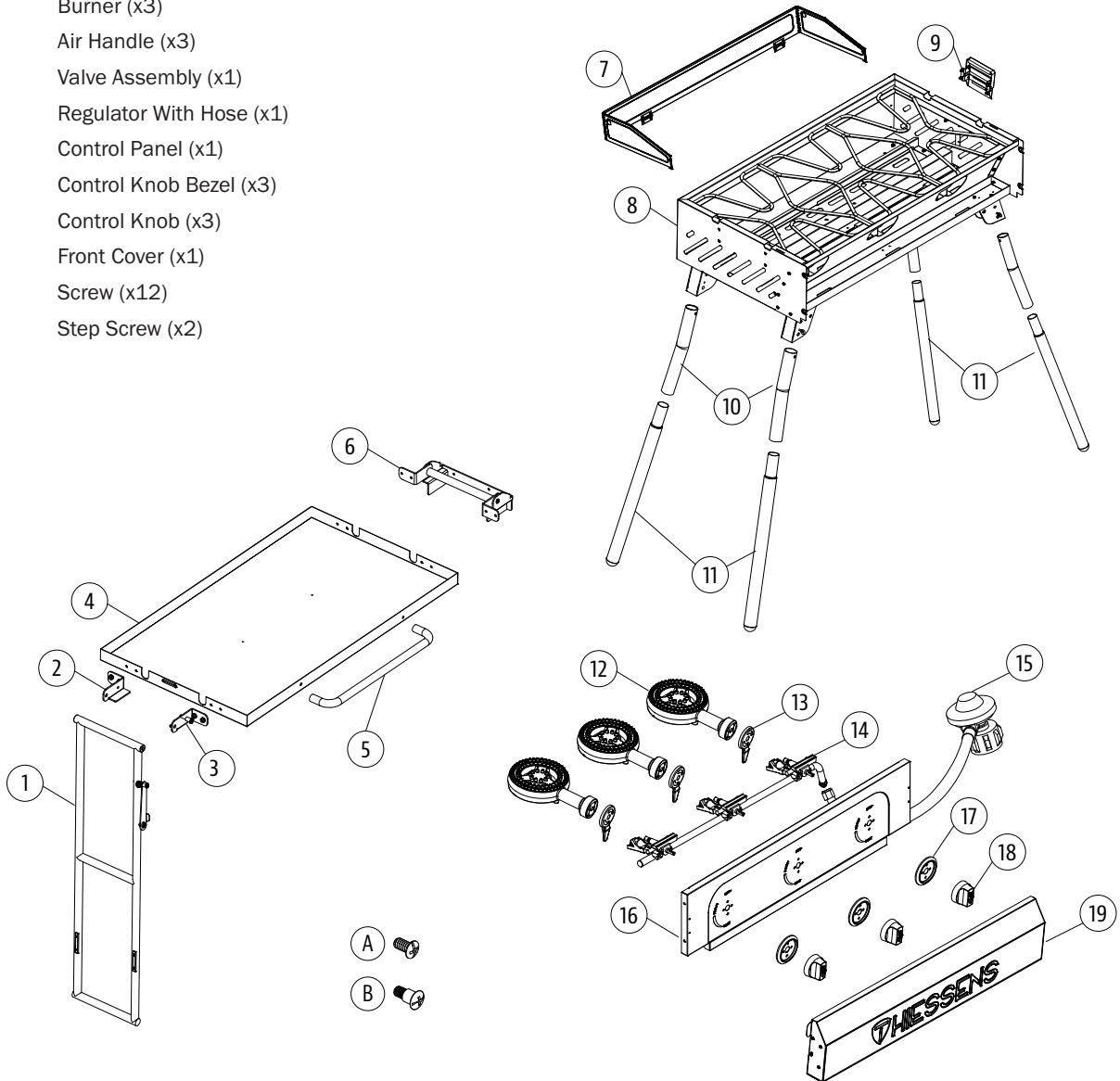

NOTE: Due to ongoing product development, parts are subject to change without notice.

WARRANTY

CONDITIONS

ALL GAS CAMP STOVES BY THIESSSENS, MANUFACTURED BY DANSONS, CARRY A LIMITED WARRANTY FROM THE DATE OF SALE BY THE ORIGINAL OWNER. THE WARRANTY COVERAGE BEGINS ON THE ORIGINAL DATE OF PURCHASE AND PROOF OF DATE OF PURCHASE, OR COPY OF ORIGINAL BILL OF SALE, IS REQUIRED TO VALIDATE THE WARRANTY. CUSTOMERS WILL BE SUBJECT TO PARTS, SHIPPING, AND HANDLING FEES IF UNABLE TO PROVIDE PROOF OF THE PURCHASE OR AFTER THE WARRANTY HAS EXPIRED. DANSONS CARRIES A TWO (2) YEAR WARRANTY AGAINST DEFECTS AND WORKMANSHIP ON ALL PARTS. DANSONS WARRANTS THAT ALL PART(S) ARE FREE OF DEFECTS IN MATERIAL AND WORKMANSHIP, FOR THE LENGTH OF USE AND OWNERSHIP OF THE ORIGINAL PURCHASER. WARRANTY DOES NOT COVER DAMAGE FROM WEAR AND TEAR, SUCH AS SCRATCHES, DENTS, DINGS, CHIPS OR MINOR COSMETIC CRACKS. THESE AESTHETIC CHANGES OF THE CAMP STOVE DO NOT AFFECT ITS PERFORMANCE. REPAIR OR REPLACEMENT OF ANY PART DOES NOT EXTEND PAST THE LIMITED WARRANTY BEYOND THE TWO (2) YEAR FROM DATE OF PURCHASE.

DURING THE TERM OF THE WARRANTY, DANSONS' OBLIGATION SHALL BE LIMITED TO FURNISHING A REPLACEMENT FOR DEFECTIVE AND/OR FAILED COMPONENTS. AS LONG AS IT IS WITHIN THE WARRANTY PERIOD, DANSONS' WILL NOT CHARGE FOR REPAIR OR REPLACEMENT FOR PARTS RETURNED, FREIGHT PREPAID, IF THE PART(S) ARE FOUND BY DANSONS' TO BE DEFECTIVE UPON EXAMINATION. DANSONS' SHALL NOT BE LIABLE FOR TRANSPORTATION CHARGES, LABOR COSTS, OR EXPORT DUTIES. EXCEPT AS PROVIDED IN THESE CONDITIONS OF WARRANTY, REPAIR OR REPLACEMENT OF PARTS IN THE MANNER AND FOR THE PERIOD OF TIME MENTIONED HERETOFORE SHALL CONSTITUTE THE FULFILLMENT OF ALL DIRECT AND DERIVATE LIABILITIES AND OBLIGATIONS FROM DANSONS TO YOU. DANSONS TAKES EVERY PRECAUTION TO UTILIZE MATERIALS THAT RETARD RUST. EVEN WITH THESE SAFEGUARDS, THE PROTECTIVE COATINGS CAN BE COMPROMISED BY VARIOUS SUBSTANCES AND CONDITIONS BEYOND DANSONS' CONTROL. HIGH TEMPERATURES, EXCESSIVE HUMIDITY, CHLORINE, INDUSTRIAL FUMES, FERTILIZERS, LAWN PESTICIDES AND SALT ARE SOME OF THE SUBSTANCES THAT CAN AFFECT METAL COATINGS. FOR THESE REASONS, THE WARRANTY DOES NOT COVER RUST OR OXIDIZATION, UNLESS THERE IS LOSS OF STRUCTURAL INTEGRITY ON THE CAMP STOVE COMPONENTS. SHOULD ANY OF THE ABOVE OCCUR, KINDLY REFER TO THE CARE AND MAINTENANCE SECTION TO PROLONG THE LIFESPAN OF YOUR UNIT. DANSONS RECOMMENDS THE USE OF A COVER WHEN THE CAMP STOVE IS NOT IN USE.

THIS WARRANTY IS BASED ON NORMAL DOMESTIC USE AND SERVICE OF THE CAMP STOVE AND NEITHER LIMITED WARRANTY COVERAGE'S APPLY FOR A CAMP STOVE WHICH IS USED IN COMMERCIAL APPLICATIONS.

EXCEPTIONS

THERE IS NO WRITTEN OR IMPLIED PERFORMANCE WARRANTY ON THIESSSENS PRODUCTS, AS THE MANUFACTURER HAS NO CONTROL OVER THE INSTALLATION, OPERATION, CLEANING, MAINTENANCE OR THE TYPE OF FUEL BURNED. THIS WARRANTY WILL NOT APPLY NOR WILL DANSONS ASSUME RESPONSIBILITY IF YOUR APPLIANCE HAS NOT BEEN INSTALLED, OPERATED, CLEANED AND MAINTAINED IN STRICT ACCORDANCE WITH THIS OWNER'S MANUAL. ANY USE OF GAS NOT OUTLINED IN THIS MANUAL MAY VOID THE WARRANTY. THE WARRANTY DOES NOT COVER DAMAGE OR BREAKAGE DUE TO MISUSE, IMPROPER HANDLING OR MODIFICATIONS. NEITHER DANSONS, OR AUTHORIZED THIESSSENS DEALER, ACCEPTS RESPONSIBILITY, LEGAL OR OTHERWISE, FOR THE INCIDENTAL OR CONSEQUENTIAL DAMAGE TO THE PROPERTY OR PERSONS RESULTING FROM THE USE OF THIS PRODUCT. WHETHER A CLAIM IS MADE AGAINST DANSONS BASED ON THE BREACH OF THIS WARRANTY OR ANY OTHER TYPE OF WARRANTY EXPRESSED OR IMPLIED BY LAW, THE MANUFACTURER SHALL IN NO EVENT BE LIABLE FOR ANY SPECIAL, INDIRECT, CONSEQUENTIAL OR OTHER DAMAGES OF ANY NATURE WHATSOEVER IN EXCESS OF THE ORIGINAL PURCHASE OF THIS PRODUCT. ALL WARRANTIES BY MANUFACTURER ARE SET FORTH HEREIN AND NO CLAIM SHALL BE MADE AGAINST MANUFACTURER ON ANY WARRANTY OR REPRESENTATION. SOME STATES DO NOT ALLOW THE EXCLUSION OR LIMITATION OF INCIDENTAL OR CONSEQUENTIAL DAMAGES, OR LIMITATIONS OF IMPLIED WARRANTIES, SO THE LIMITATIONS OR EXCLUSIONS SET FORTH IN THIS LIMITED WARRANTY MAY NOT APPLY TO YOU. THIS LIMITED WARRANTY GIVES YOU SPECIFIC LEGAL RIGHTS AND YOU MAY HAVE OTHER RIGHTS, WHICH VARY FROM STATE TO STATE.

WARRANTY SERVICE

CONTACT YOUR NEAREST THIESSSENS DEALER FOR REPAIR OR REPLACEMENT PARTS. DANSONS REQUIRES PROOF OF PURCHASE TO ESTABLISH A WARRANTY CLAIM; THEREFORE, RETAIN YOUR ORIGINAL SALES RECEIPT OR INVOICE FOR FUTURE REFERENCE. THE SERIAL AND MODEL NUMBER OF YOUR UNIT CAN BE FOUND ON THE BACK OF THE UNIT. RECORD NUMBERS BELOW AS THE LABEL MAY BECOME WORN OR ILLEGIBLE.

MODEL

SERIAL NUMBER

DATE OF PURCHASE

AUTHORIZED DEALER

CONTACT CUSTOMER CARE

IF YOU HAVE ANY QUESTIONS OR PROBLEMS, CONTACT CUSTOMER CARE.
WWW.THIESSSENS.COM | TOLL-FREE: 1-877-972-5742



CONTACT CUSTOMER CARE

IF YOU HAVE ANY QUESTIONS OR PROBLEMS,
CONTACT CUSTOMER CARE.

WWW.THIESSSENS.COM | TOLL-FREE: 1-877-972-5742

MADE IN CHINA



602210621UMV



WARNING: COMBUSTION OF PROPANE GAS CAN EXPOSE YOU TO CHEMICALS INCLUDING FORMALDEHYDE, WHICH IS KNOWN TO THE STATE OF CALIFORNIA TO CAUSE CANCER, AND CARBON MONOXIDE, WHICH IS KNOWN TO THE STATE OF CALIFORNIA TO CAUSE BIRTH DEFECTS OR OTHER REPRODUCTIVE HARM. FOR MORE INFORMATION GO TO WWW.P65WARNINGS.CA.GOV