

INSTRUCTION MANUAL

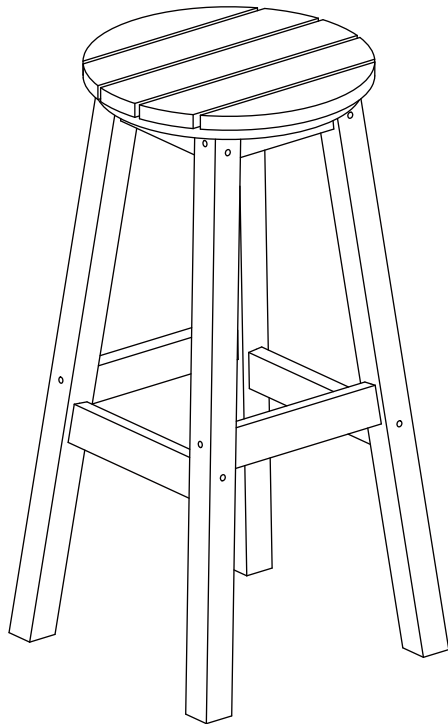

29" Round Bar Stool
SKU: OP7012

V1.0

! NOTICE

Do not overtighten screws. (Insert all screws before tighten screws.)

- Please do not exceed the weight limitations of this item.
- Do not stand on or use any part of this item as a step ladder.
- Firmly secure all bolts, screws and nuts before use.
- Reconfirm that all bolts, screws, and nuts are secure every 90 days.
- Do not use or store this item in the proximity of open flame or flammable/combustible chemicals.
- Be aware that some parts are heavy and have sharp edges.
- Please adjust the speed slowly when you use electric drill for assembling to avoid screw slippage.

TOOLS REQUIRED

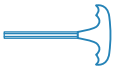

ALLEN WRENCH
(PROVIDED)



TABLE
330 LBS
CAPACITY



1 PERSON
ASSEMBLY



UP TO 20MIN.
ASSEMBLY

HARDWARE

1

M6.3 x70mm
BOLT



16 PCS

2

ALLEN
WRENCH



1 PC

PARTS

A

STOOL TOP

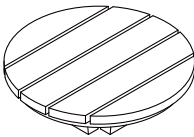

1 PC

B

STOOL LEG I



2 PCS

C

STOOL LEG II



2 PCS

D

SHORT RAIL



2 PCS

E

LONG RAIL



2 PCS

PRODUCT ASSEMBLY-OVERALL VIEW

1

Look at following overall view of this table and exact position of each parts to be assembled.

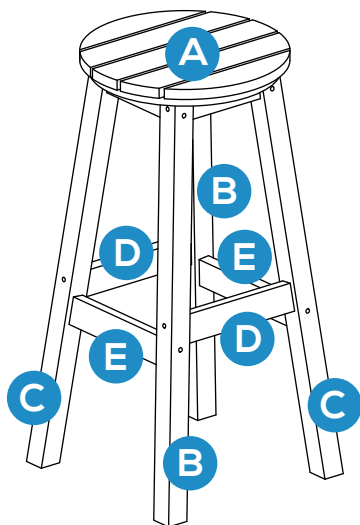

PRODUCT ASSEMBLY

1

Attach part B&C Stool leg to part A Stool top with 8 pcs of Hardware 1 Bolt.

Notice: Please attach the Stool Leg to the right high and low screw hole

Do not tighten screws too much at this step.

Please pay attention to the high and low screw holes before installation

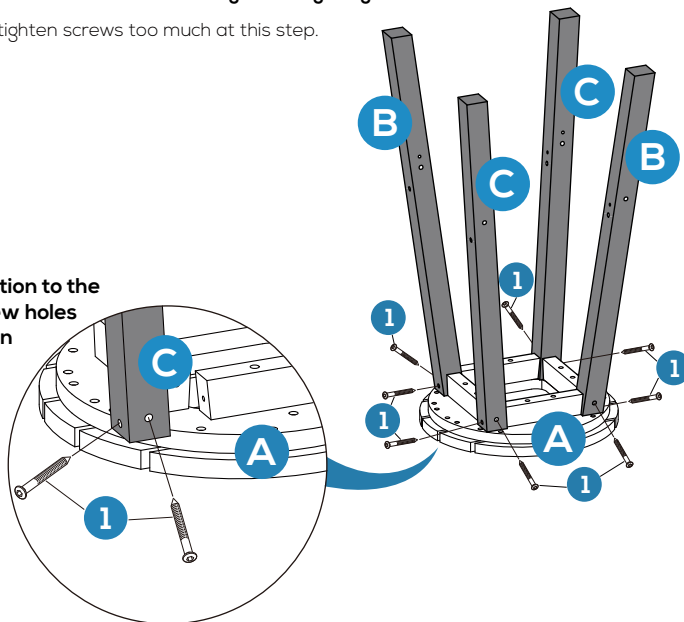

PRODUCT ASSEMBLY

2

Remove the cap from the safety pin before you fix the part D Short Rail to part B & C Stool legs. Attach part D Short Rail to part C and part B Stool Legs with 4 pcs of Hardware 1 Bolt. Do not tighten screws too much at this step.

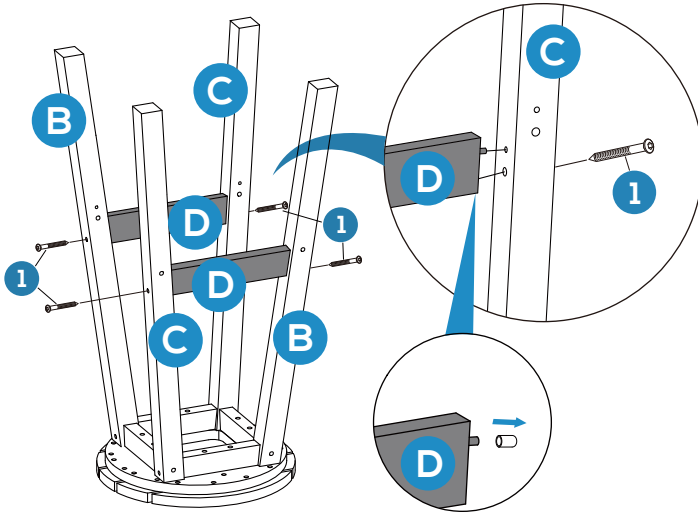

move the cap only.

3

Remove the cap from the safety pin before you fix the Long Rail to Stool legs. Attach part E Long Rail to the combined legs (part C+D+B) as below with 4 PCS of Hardware 1 Bolts. Do not tighten screws too much at this step.

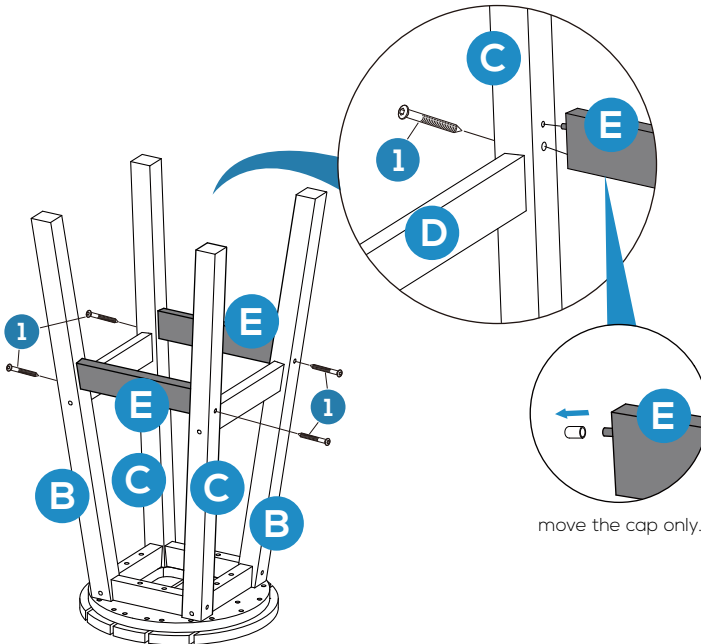

move the cap only.

PRODUCT ASSEMBLY

4

Check and tighten all the bolts and screws again and finish the assembly.

