





Thank you for purchasing this quality product. Be sure to unpack carefully looking for small parts which may have come loose during shipment.
Read all instruction and study the drawing carefully before starting the assembly process:

HARDWARE PACK

NO	DRAWING	DESCRIPTION	SIZE	Q'TY
A		BOLT	Ø ⁵ / ₁₆ " x 1 ⁹ / ₁₆ "	08 pcs
B		LOCK WASHER	Ø ⁵ / ₁₆ "	08 pcs
C		FLAT WASHER	Ø ⁵ / ₁₆ " x ³ / ₄ "	08 pcs
D		ALLEN KEY	⁵ / ₃₂ "	1 pc

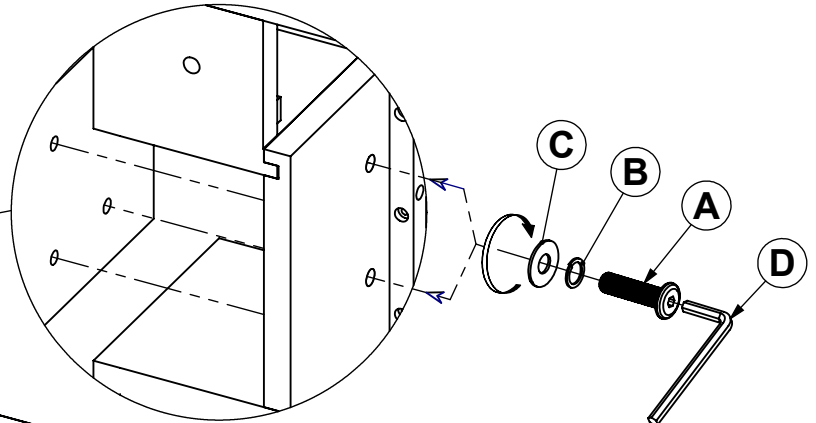

Step 1

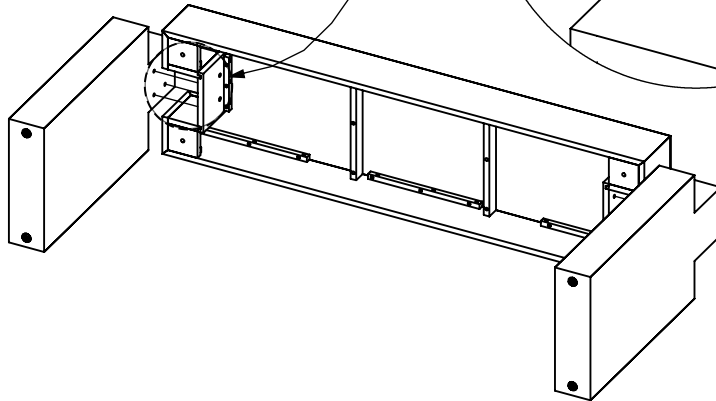

Step 2

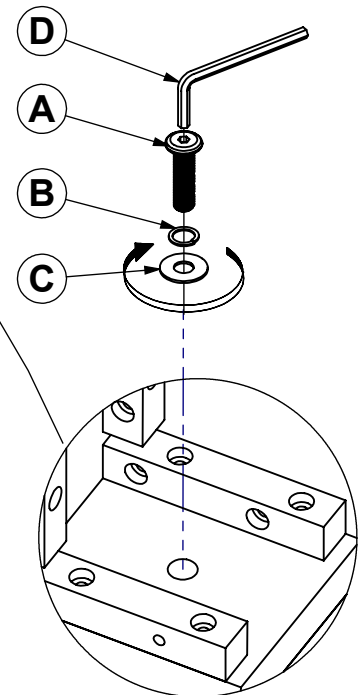
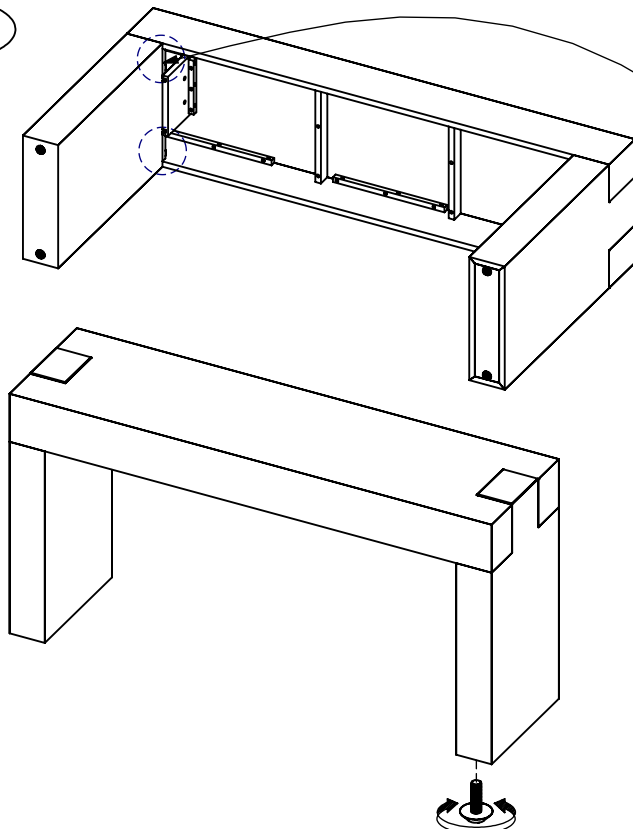

Adjust levelers if needed, to the level case on uneven floor