

# INSTRUCTION MANUAL

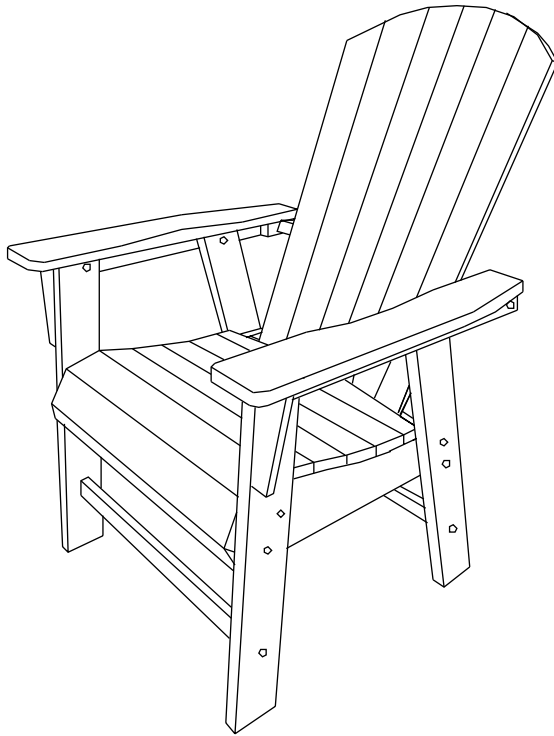

**Seashell Adirondack Dining Chair**  
**SKU: OP2010**

**V1.0**

## ! NOTICE

### Do not overtighten screws. (Insert all screws before tighten screws.)

- Please do not exceed the weight limitations of this item.
- Do not stand on or use any part of this item as a step ladder.
- Firmly secure all bolts, screws and nuts before use.
- Reconfirm that all bolts, screws, and nuts are secure every 90 days.
- Do not use or store this item in the proximity of open flame or flammable/combustible chemicals.
- Be aware that some parts are heavy and have sharp edges.
- Please adjust the speed slowly when you use electric drill for assembling to avoid screw slippage.

## TOOLS REQUIRED



ALLEN WRENCH  
(PROVIDED)



WRENCH  
(PROVIDED)



CHAIR  
330 LBS  
CAPACITY



1 PERSON  
ASSEMBLY



UP TO 30 MIN.  
ASSEMBLY

## HARDWARE

1

M6.3 x 80mm  
SCREW

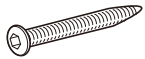

4 PCS

2

M6 x 55mm  
BOLT



10 PCS

3

M6 x 45mm  
BOLT



4 PCS

4

M6 NUT



10 PCS

5

M6 WASHER



10 PCS

6

WRENCH



1 PC

7

ALLEN  
WRENCH

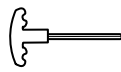

1 PC

## PARTS

A

CHAIR BACKREST

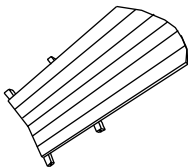

1 PC

B

CHAIR SEAT

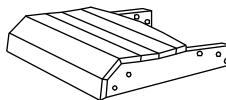

1 PC

C

RIGHT CHAIR ARM

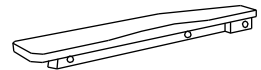

1 PC

## PARTS

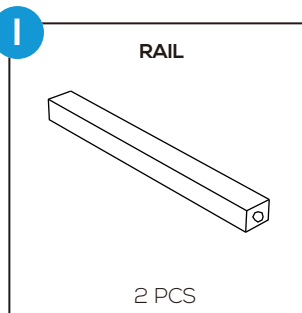
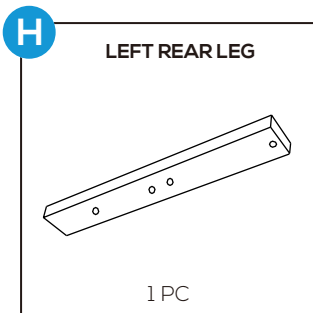
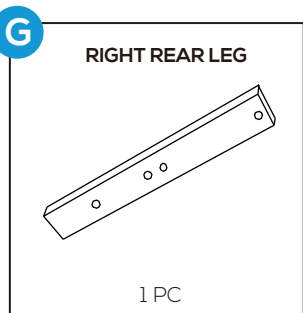
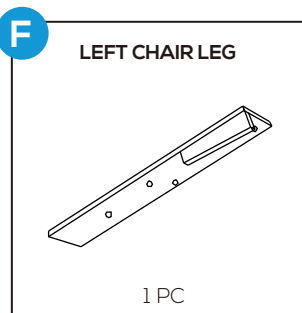
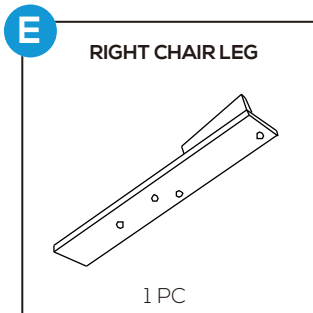
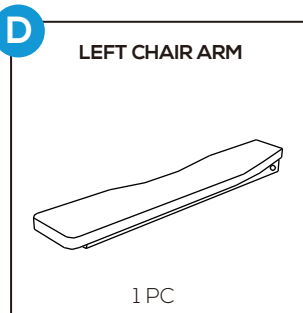

## PRODUCT ASSEMBLY - OVERALL VIEW

Look at the overall view of this chair and learn the exact position of each part to be assembled.

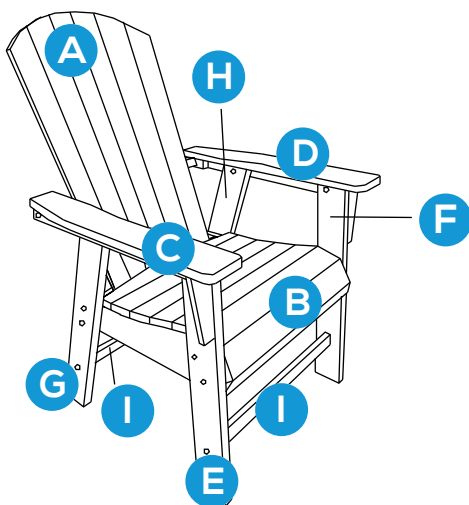

## PRODUCT ASSEMBLY

**1**

Place part A Chair Backrest and part B Chair Seat as below, attach part H Left Rear Leg to part B Chair Seat and part A Chair Backrest with 1 PC of hardware 1 Screw,

Do not tighten screws too much at this stage.

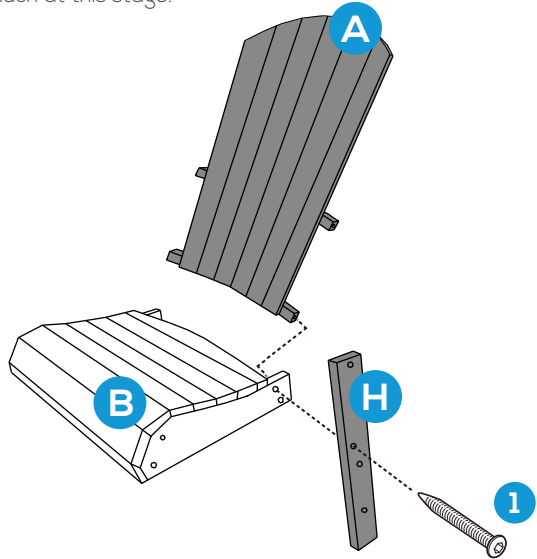

**2**

Attach part H Left Rear Leg to part B Chair Seat with 1 set of hardware 2 Bolt, hardware 5 Washer and hardware 4 Nut.

Attach part I Back Rail to part H Left Rear Leg with 1 PC of hardware 3 Bolt.

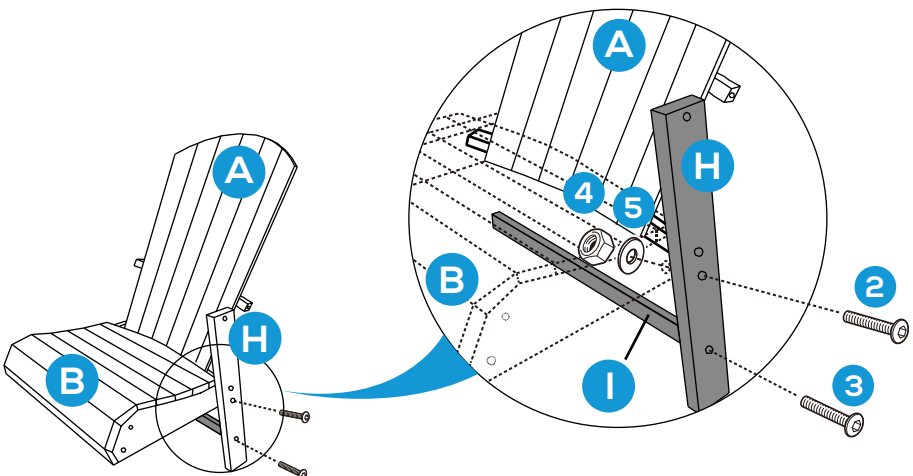

## PRODUCT ASSEMBLY

**3**

Attach part F Left Chair Leg to part B Chair Seat with 2 sets of hardware 2 Bolt, hardware 5 Washer and hardware 4 Nut.

Attach part I Front Rail to part F Left Chair Leg with 1 PC of hardware 3 Bolt.

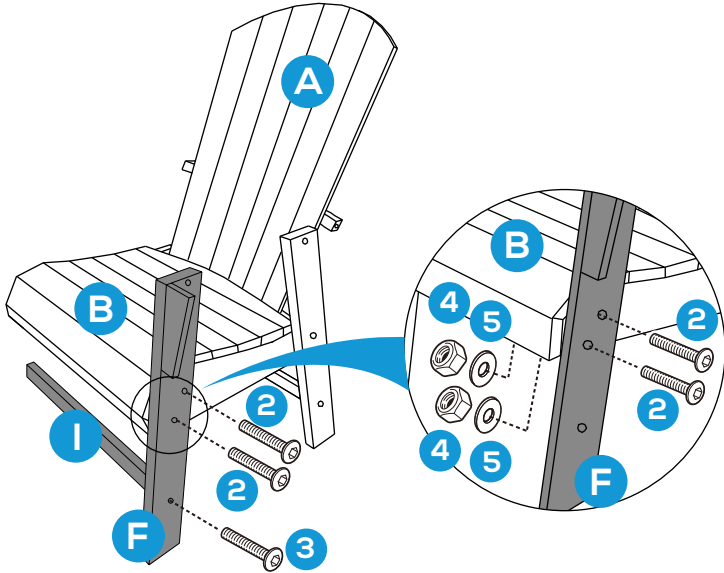

**4**

Do the same to attach part E Right Chair Leg and part G Right Rear Leg to part A and B with 3 sets of hardware 2 Bolt, hardware 5 Washer and hardware 4 Nut as well as 1 PC of hardware 1 Screw.

Attach part E and G to part I Rails with 2 PCS of hardware 3 Bolt.

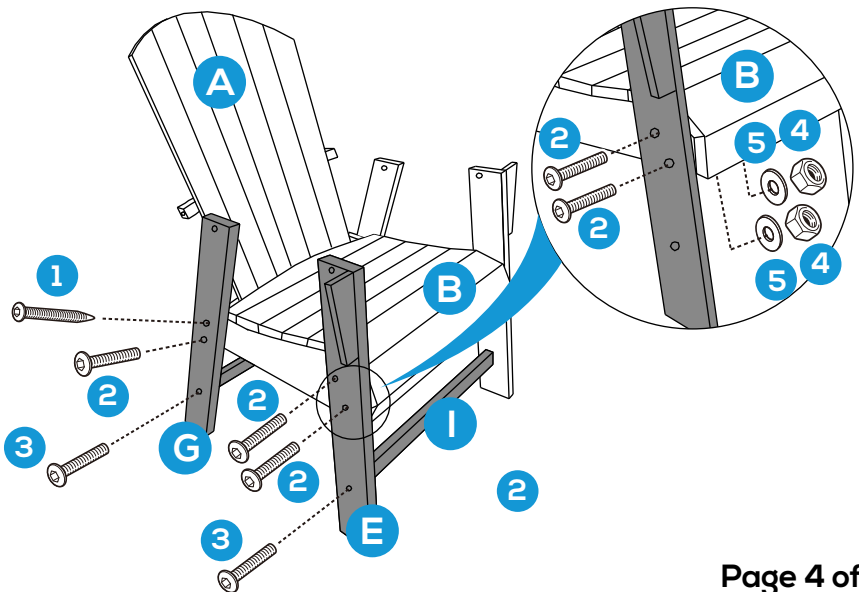

## PRODUCT ASSEMBLY

5

Attach part D Left Chair Arm to part A Chair Backrest with 1 PC of hardware 1 Screw.

Attach part D Left Chair Arm to part F Left Chair Leg and part H Left Rear Leg with 2 sets of hardware 2 Bolt, hardware 5 Washer and hardware 4 Nut.

Do the same to attach part C Right Chair Arm to the chair to finish the assembly.

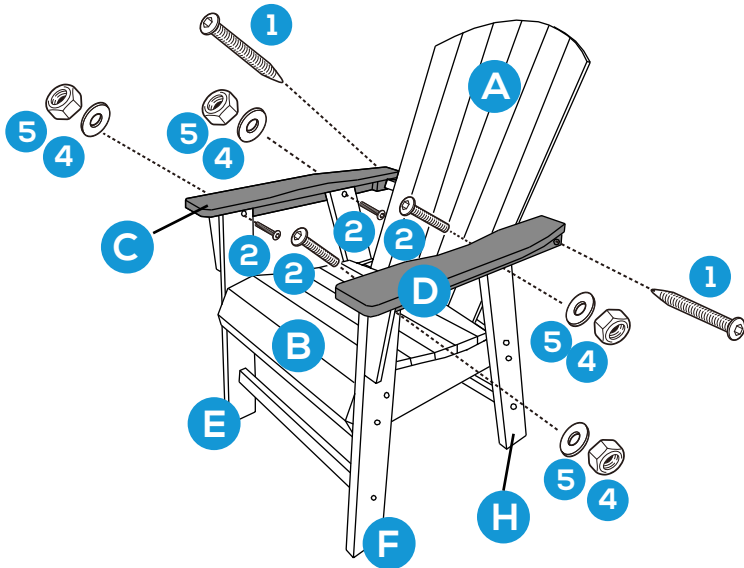

6

Tighten all the bolts and screws again to ensure this chair is steady enough to use.

