

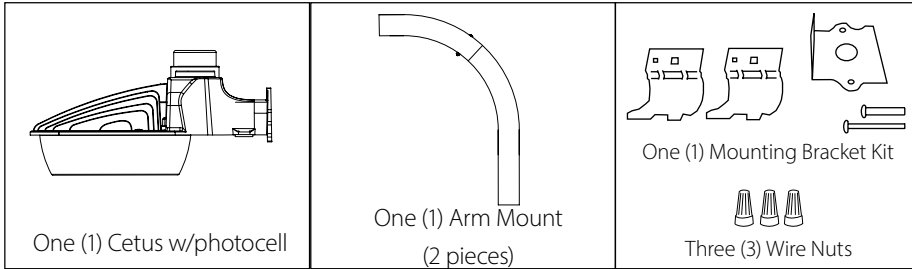

**SAFETY PRECAUTIONS**

- Read instructions carefully before attempting to install fixture. Retain instruction for future reference.
- Disconnect power before installing or servicing. This fixture must be wired in accordance with the National Electrical Code and applicable local codes and ordinances.
- All wiring should be performed by a qualified electrician. This fixture is for outdoor use and should not be used in areas with limited ventilation or high ambient temperatures.

**What's In The Box**



**Tools Needed**

A screwdriver, drill, a pair of wire strippers, and fasteners appropriate for the mounting surface will be needed to install the Cetus.

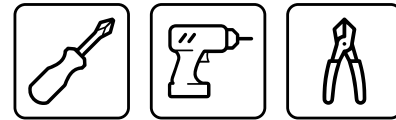

**Installation**

- Carefully unpack fixture from packaging and inspect for any damage caused in shipping
- Turn off power using appropriate switch/breaker
- Locate desired positioning for the fixture on the mounting surface

**Direct Surface Mount**

- See Figures 1 and 2
- Remove pipe clamp from bottom of fixture
- Remove desired knockout on wiring cover
- Pull wires through wiring cover and connect wires per wiring diagram: White to Neutral, Black to Line, Green to Ground
- Install wiring cover on bottom of fixture, tightening two bolts
- Use expansion bolts to secure the fixture to the mounting surface

**Wiring Diagram**

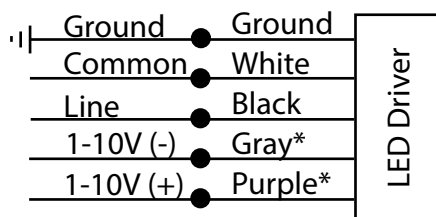

\*Cap if not used. Dimming wires not present on 50W model.

**Fig 1**

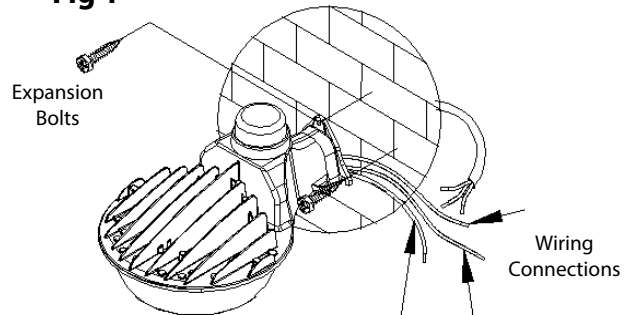

**Fig 2**

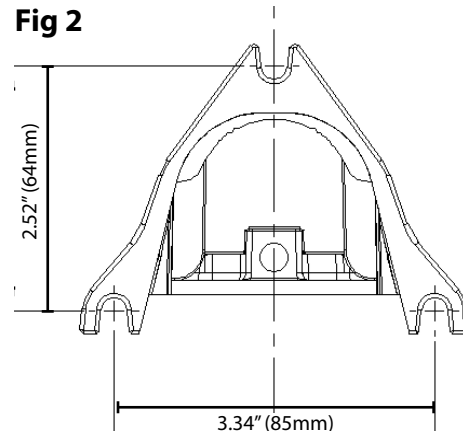

**Surface Mount to Wall**

**5** Attach mounting bracket to lower section of arm opposite of the reduced end. Do not fully tighten clamp to allow for fixture orientation at a later step.

Mount lower arm to wall in desired location using appropriate hardware.

Install top section of arm to lower section of arm and lock in place with bolt, washer and nut.

Pull supply wiring through arm.

Connect fixture and supply wires per the wiring diagram: White to Neutral, Black to Line, Green to Ground.

Loosen clamp on bottom of fixture and insert fixture onto arm. Tighten bolts to firmly clamp fixture to pipe, ensuring it does not rotate.

Position arm in desired orientation and firmly clamp the mounting bracket around the arm.

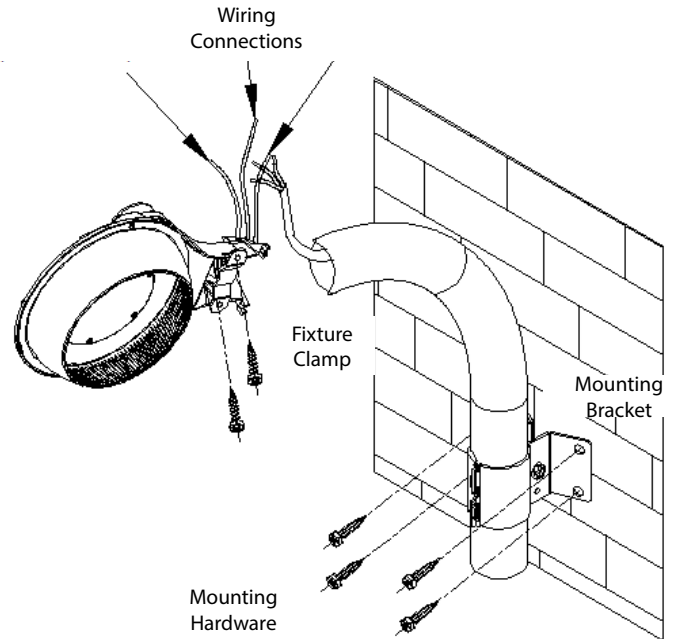

**Wiring Diagram**

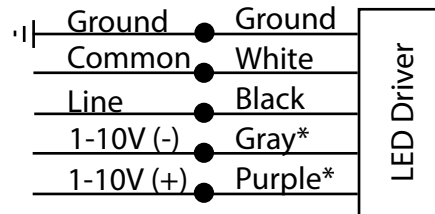

\*Cap if not used.

Dimming wires not present on 50W model.

**NICOR LED Express Limited Warranty**

Subject to the exclusions below, each NICOR LED product, including the LED electronics and components of a property installed NICOR LED product, will be free from defect in materials and workmanship for a period of five (5) years from the original date of purchase. The product shall be considered defective only if 10% or more of the product's LED components fail. NICOR LED product warranty covers the following performance criteria: LED Light Output will be maintained above 70% of initial output; LED color temperature will not shift more than 200K in CCT; LED driver will operate within NICOR specifications; and the fixture finish, excluding natural aluminum or brass products, will not exhibit cracking, peeling, excessive fading, or corrosion during the warranty period. Exceptions apply as defined in NICOR's product specification sheets, which are incorporated by reference herein.

This limited warranty is provided to you, the purchaser of the product identified on Seller's invoice, as your exclusive remedy and applies only to NICOR products that have been purchased from an authorized NICOR Distributor; the product was new and in an unopened NICOR package at the time of installation; and the NICOR product was installed by a licensed electrician or under the supervision of a licensed electrician and used by consumers in the United States or Canada when accompanied with this warranty. This warranty extends only to the first consumer purchaser and is not transferable. A consumer wishing to invoke the terms of this limited warranty must first obtain a RGA number within 30 days of discovery of the defect, and return the product to NICOR for inspection. Once verified to be covered by this limited warranty, NICOR will, at its sole discretion, repair, replace, or refund the purchase price of any product that does not conform to this limited warranty. If NICOR, at its sole discretion, determines that the product should be repaired or replaced, this warranty is limited to the reasonable, customary, and necessary costs and expenses associated with the repair/replacement. This warranty requires that all repair/replacement estimates and costs, including but not limited to equipment rental (if any), and any other cost or expense to be incurred in the repair/replacement of the product, be approved in advance and in writing by NICOR. FAILURE TO OBTAIN NICOR'S ADVANCE WRITTEN APPROVAL OF ALL REPAIR/REPLACEMENT COSTS AND EXPENSES IN WRITING SHALL VOID THIS LIMITED WARRANTY.

**THIS LIMITED WARRANTY DOES NOT COVER THE FOLLOWING:**

- Defects or damages resulting from improper installation, operation, storage, misuse or abuse, accident, or neglect;
- Defects or damages resulting from improper service, testing, adjustment, installation, maintenance, alteration, connection to out-of-specification electrical service, corrosive or damp environments, or connection to incompatible equipment or devices (e.g., connecting non-dimmable lighting products to dimmers);
- Damage which occurs in transit;
- Power surges or overheating due to external conditions
- Acts of nature including but not limited to lightning strikes

ANY IMPLIED WARRANTIES, INCLUDING WITHOUT LIMITATION, THE IMPLIED WARRANTIES OF MERCHANTABILITY AND FITNESS FOR A PARTICULAR PURPOSE SHALL BE LIMITED TO THE DURATION OF THIS LIMITED WARRANTY, OTHERWISE THE REPAIR, REPLACEMENT, OR REFUND AS PROVIDED UNDER THIS EXPRESS LIMITED WARRANTY IS THE EXCLUSIVE REMEDY OF THE CONSUMER, AND IS PROVIDED IN LIEU OF ALL OTHER WARRANTIES, EXPRESS OR IMPLIED. IN NO EVENT SHALL NICOR BE LIABLE, WHETHER IN CONTRACT OR IN TORT (INCLUDING NEGLIGENCE) FOR DAMAGES IN EXCESS OF THE PURCHASE PRICE OF THE PRODUCT, OR FOR ANY INDIRECT, INCIDENTAL, SPECIAL OR CONSEQUENTIAL DAMAGES OF ANY KIND, OR LOSS OF REVENUE OR PROFITS, LOSS OF BUSINESS OR OTHER FINANCIAL LOSS ARISING OUT OF OR IN CONNECTION WITH THE ABILITY OR INABILITY TO USE THE PRODUCT TO THE FULL EXTENT THESE DAMAGES MAY BE DISCLAIMED BY LAW.

This device complies with part 15 of the FCC Rules. Operation is subject to the following two conditions: (1) This device may not cause harmful interference, and (2) this device must accept any interference received, including interference that may cause undesired operation.

NOTE: This equipment has been tested and found to comply with the limits for a Class A digital device, pursuant to part 15 of the FCC Rules. These limits are designed to provide reasonable protection against harmful interference when the equipment is operated in a commercial environment. This equipment generates, uses, and can radiate radio frequency energy and, if not installed and used in accordance with the instruction manual, may cause harmful interference to radio communications. Operation of this equipment in a residential area is likely to cause harmful interference in which case the user will be required to correct the interference at his own expense.

# THANK YOU

## FOR YOUR PURCHASE

**SHARE YOUR EXPERIENCE WITH US****SCAN the QR or visit**[www.nicorlighting.com/support/survey](http://www.nicorlighting.com/support/survey)**FOLLOW US****YouTube**