

Seat shall be Comfort™ Seats

Model Number C2200HPSS

Premium Plastic Toilet Seat

Elongated Closed Front with Cover

Category

LIGHT COMMERCIAL

Features

- Injection molded durable polypropylene plastic UV protection
- Molded in bumpers
- Matching adjustable hinge
- 304 stainless steel bolt, nuts and washers
- Rubberized non-skid pads
- Top mount design

Seat Color/Finish

Specify white or black

Hinge Color/Finish

Specify white or black

Product Specifications

Hinge Design: Heavy duty, large diameter,

Ring Thickness: 5/8"

Ring Thickness with Bumper: 7/8"

Height of Seat with Cover: 2 3/4"

Size: ANSI Standard Toilet - Meets Z124.5 Section 5.1.2

Additional Information

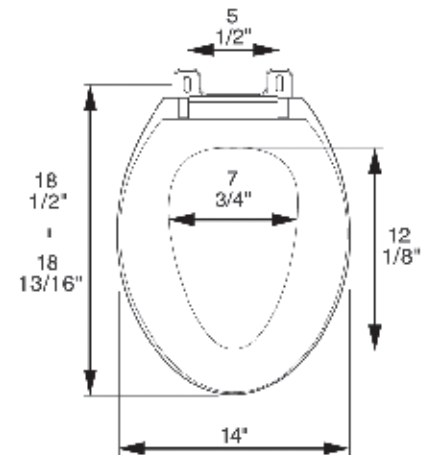

Corrosion proof, self-aligning hardware