

# ChildLife<sup>®</sup>

## Playsets

### Convertible Picnic Table For Leopards Lair

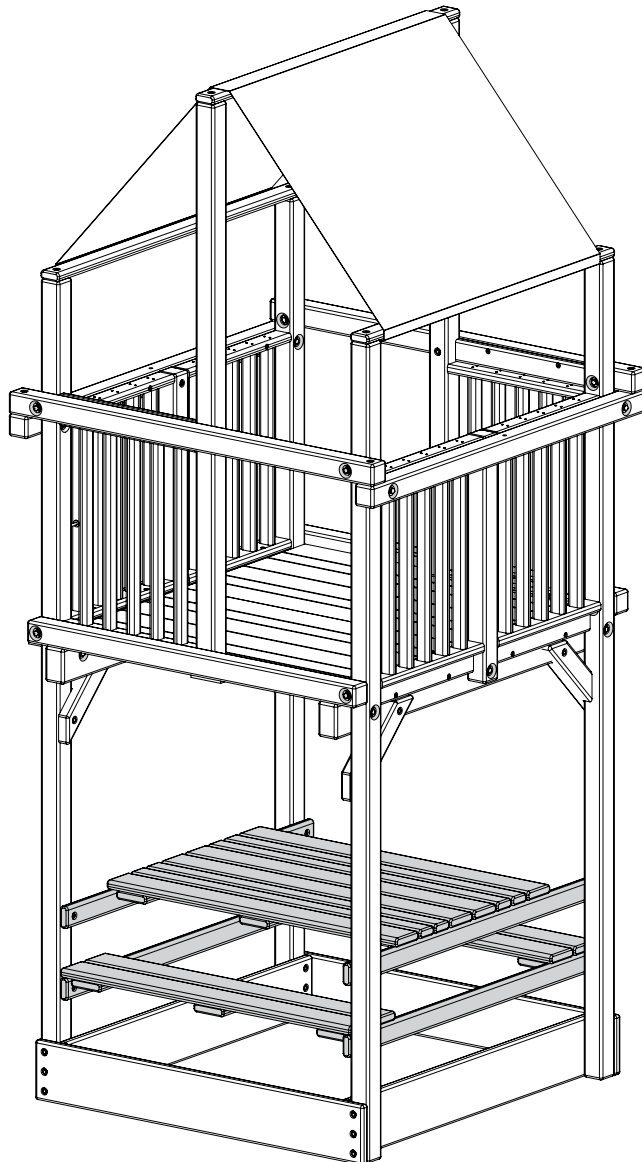

PG-MA-0030-02

## PARTS LIST

#	PART NUMBER	DESCRIPTION	QTY.
1	PG-2X4-054-DEK	2 x 4 x 53 5/8" Deck / Picnic Table Board	4
2	PG-2X6-054-DEK	2 x 6 x 53 5/8" Deck / Picnic Table Board	8
3	PG-2X6-010-BB	2 x 6 x 9 5/8" Picnic Tbl Backboard	6
4	PG-2X6-018-BB	2 x 6 x 17 3/4" Picnic Tbl Backboard	6
5	PG-2X4-061-HRS	2 x 4 x 60 5/8" Horizontal Roof Support	3
6	PG-HW-W004	3/8" Flat Washer	6
7	PG-HW-L011	3/8" x 3" Lag Screw	6
8	PG-HW-S009	#8 X 2-1/2 Wood Screw	72

# Top View

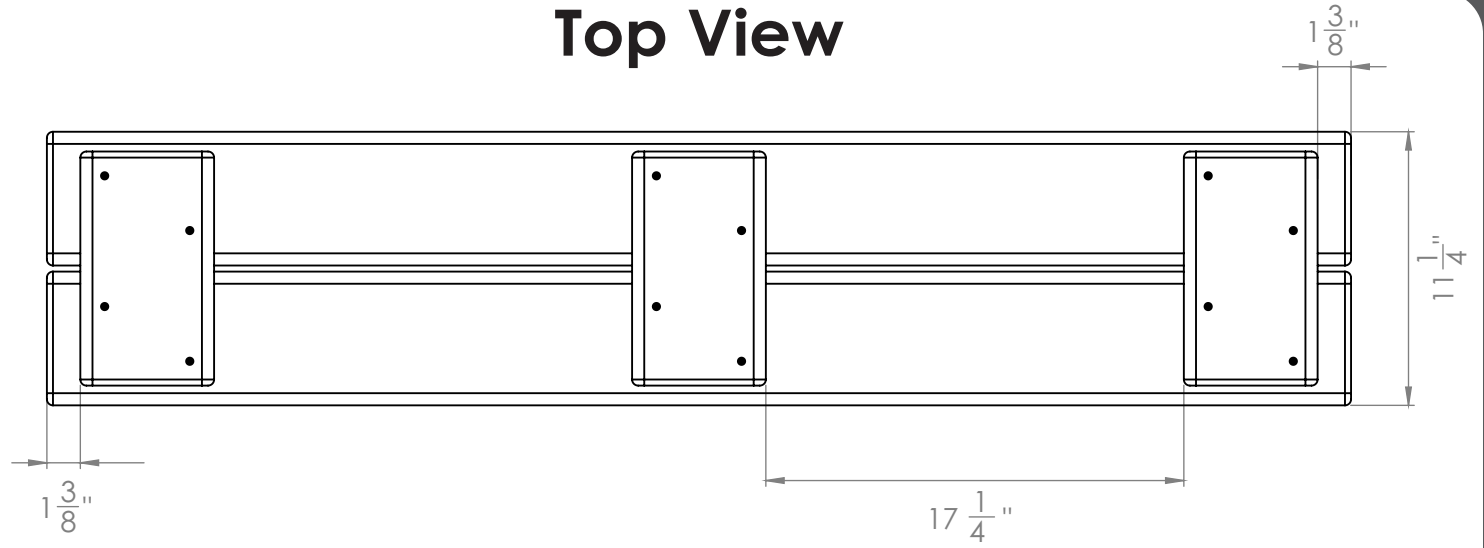

Assemble two Seat section as shown.

2X

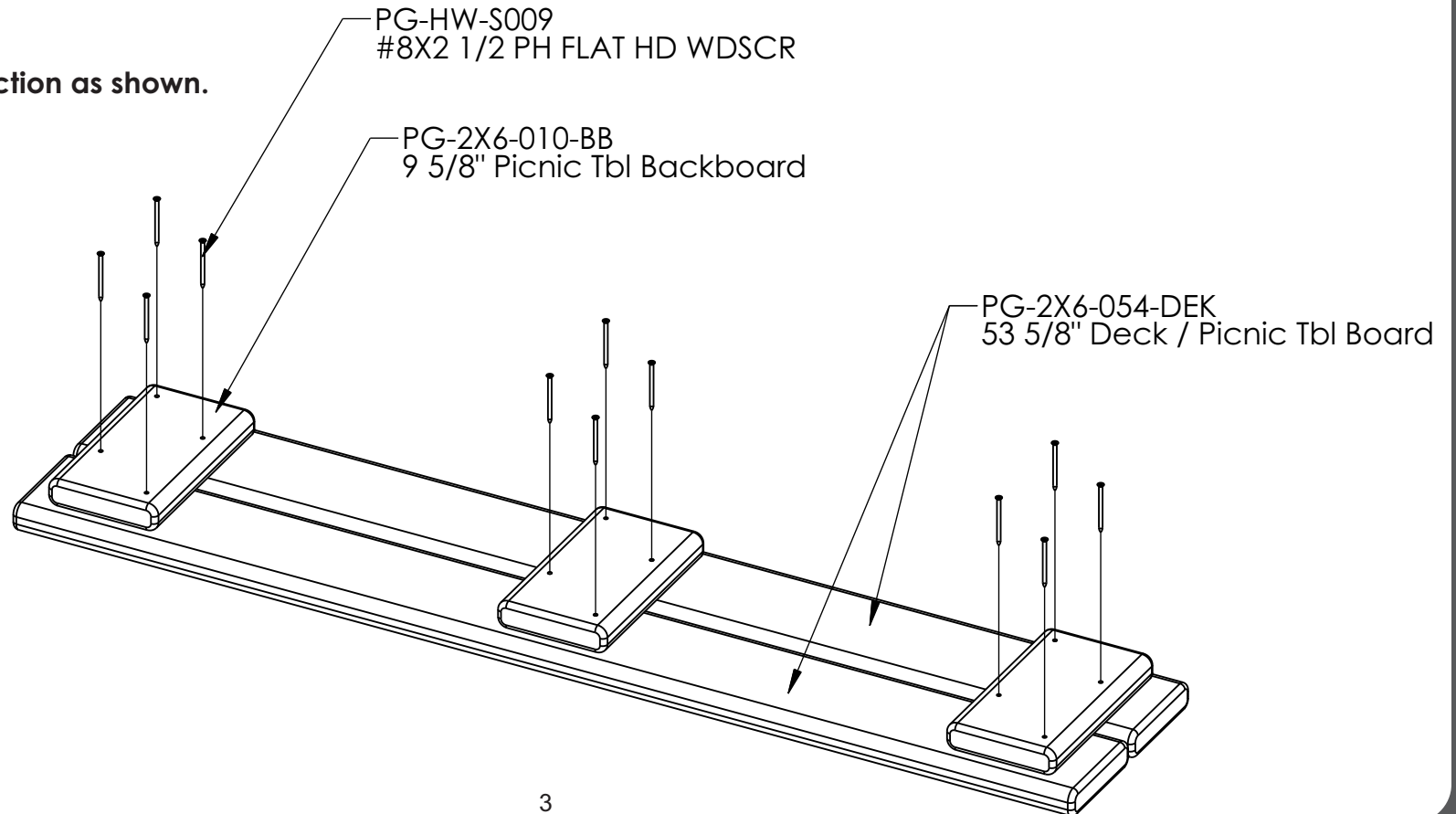

# Top View

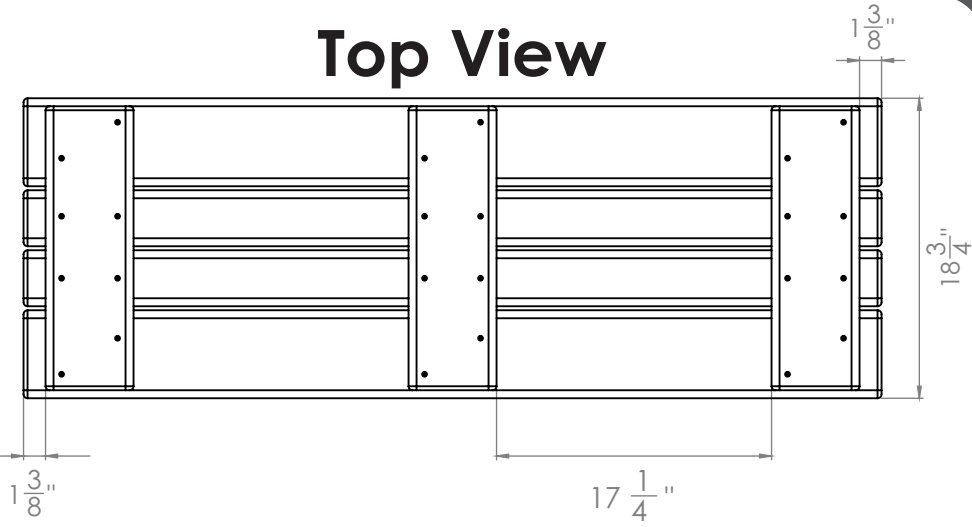

Assemble two Top sections as shown.

2X

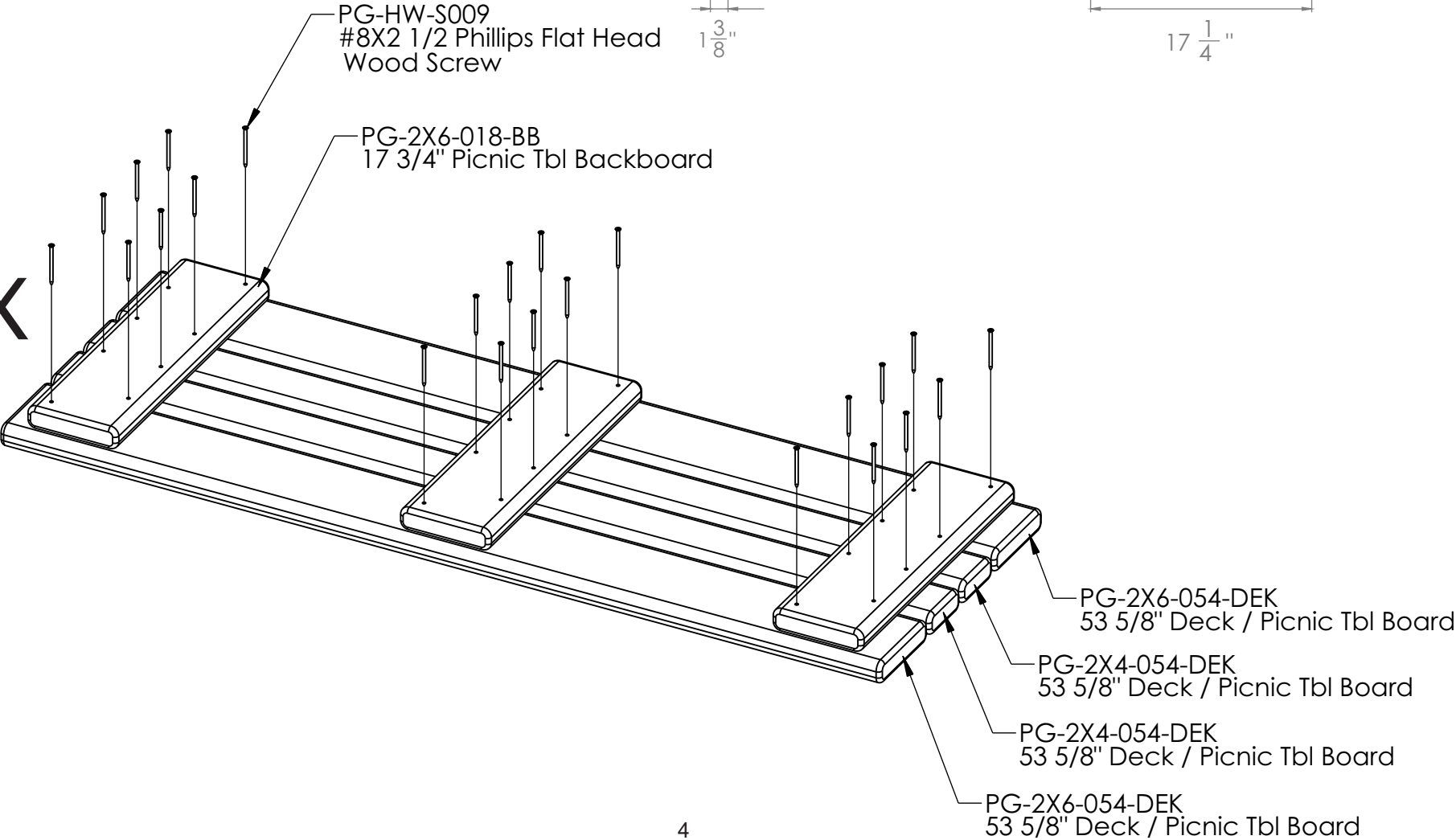

Attach supports as shown. 19" to top of the lower supports and 29" to top of the upper supports.

**REPEAT PROCESS FOR OPPOSITE SIDE OF UNIT.**

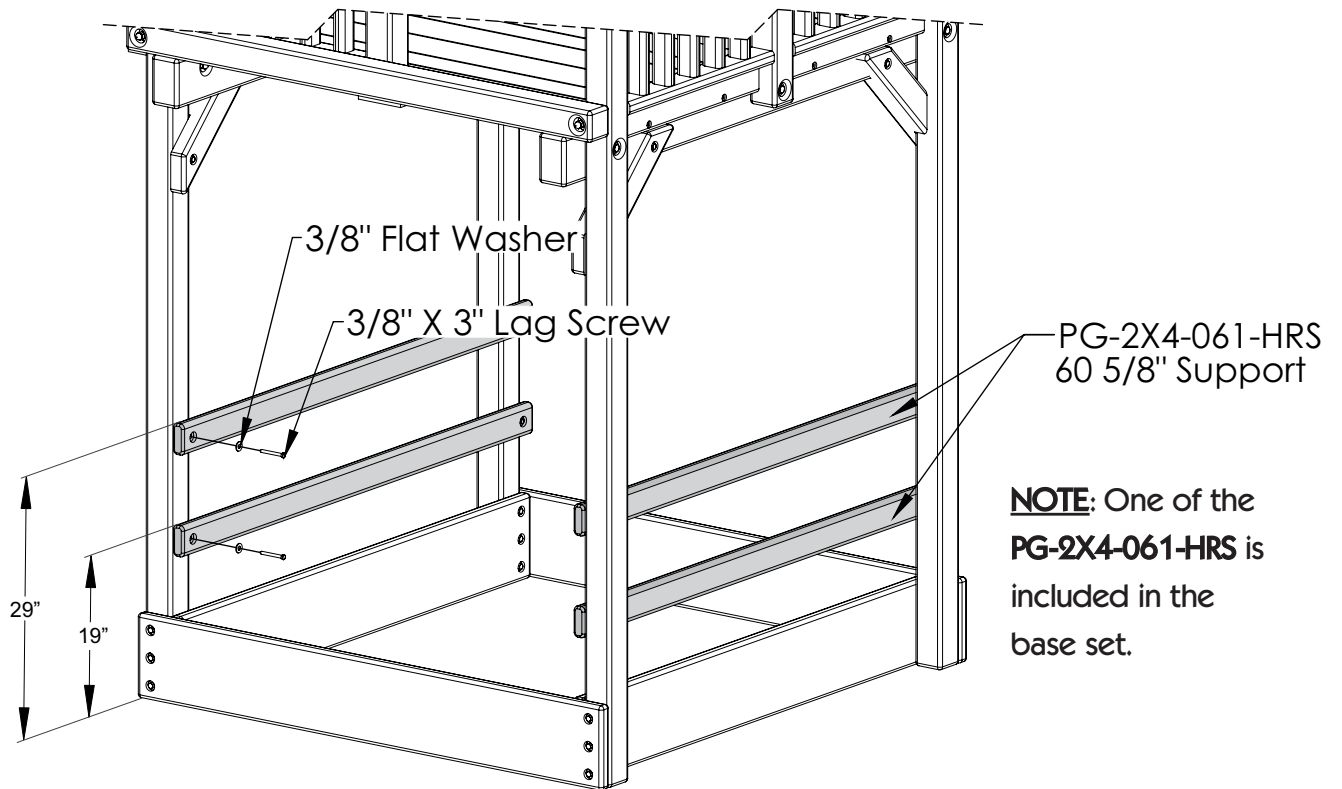

Place **Top** and **Seats** on **Supports** as shown.

They can also be used as a sandbox cover when placed on top of sandbox sides.

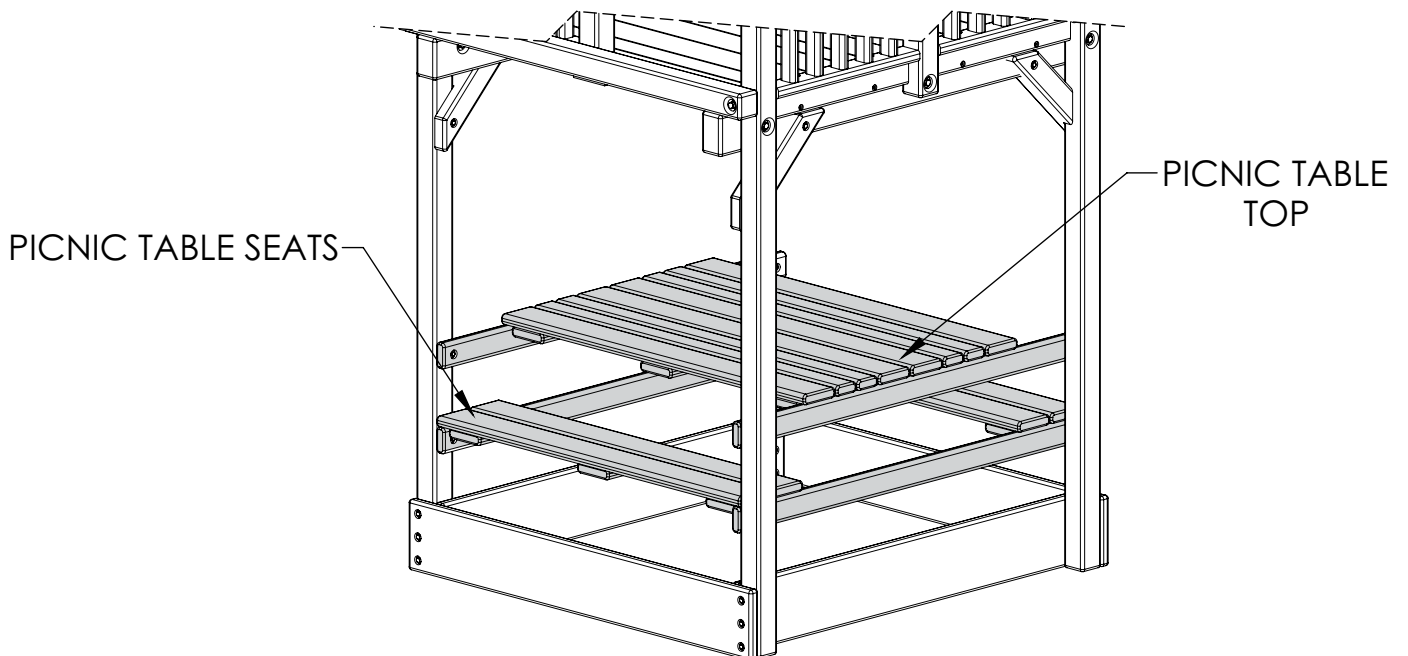

# ChildLife® Playsets

**ChildLife Limited Lifetime  
& TwoYear Warranties**

Subject to proper installation and normal residential use, Escalade Sports warrants, subject to the limitations stated below, to the original retail purchaser, all chain, seats, swing hangers, hardware, metal braces, ropes and accessories to be free from defects in material and workmanship for a period of two years from date of purchase. Cracks in non-functional plastic components are not considered defects in materials and workmanship if they do not affect the functionality of the playset. Merchandise covered under this limited two-year warranty will, at our option, be repaired or replaced, excluding **any freight or labor fees that may be required.**

In addition, for the lifetime of the playset, Escalade Sports warrants, to the original retail purchaser, all wooden components against structural failure due to corrosion, wood rot, or insect infestation. **Seasonal checks and surface cracks, knotholes and knots, natural characteristics of all wooden play equipment, not resulting in structural failure, are not covered under this warranty.**

Timber is a natural material which can absorb and release moisture. Although this product is designed to minimize this effect, in certain circumstances some movement or distortion is unavoidable. During dry hot weather timber may shrink and check - this is a normal process of weathering. After the first year of service it is advisable to apply a non-toxic stain / sealant safe for children's use.

Components covered under this limited lifetime warranty will be replaced free of charge excluding freight and labor fees.

**Non-residential use of the playset is prohibited and voids the warranty as the playsets are designed for residential use only.**

Escalade Sports reserves the right to examine photographs and/or physical evidence of merchandise claimed to be defective, and to recover said merchandise, prior to disposition of warranty claims. Merchandise returned to our factory for examination or recovery must be shipped freight prepaid, unless a Return Authorization Number is issued.

No warranty is offered on equipment subjected to abuse, negligence, improper installation, vandalism, acts of God, unauthorized alteration or attachment to equipment other than our own, or improper use, service or repair by customer or any third party. Escalade Sports assumes no responsibility for incidental or consequential damages which may arise from the purchase or use of our equipment. Please supervise your children's play activity and maintain your play equipment periodically.

THIS WARRANTY IS EXPRESSLY IN LIEU OF ALL OTHER WARRANTIES, EXPRESSED OR IMPLIED, INCLUDING WARRANTIES OF MERCHANTABILITY OR FITNESS FOR USE. CHILDLIFE PLAYSETS DOES NOT ASSUME, OR AUTHORIZE ANY PERSON TO ASSUME FOR US, ANY OTHER LIABILITY IN CONNECTION WITH THE SALE OF OUR PRODUCTS.

**For warranty service, contact:**

**Childlife Playsets  
Escalade Sports  
P.O. Box 889  
Evansville, IN 47706  
1-800-GO-SWING**

Or E-Mail us at: [playgroundcs@escaladesports.com](mailto:playgroundcs@escaladesports.com)

Revised 2014