

PALMGREN[®]
a CH Hanson brand



Disc Sander with Stand

Models 9681314, 9681315, 9681316 and 9681317

PALMGREN[®]
a CH Hanson brand

**PLEASE READ AND SAVE
THESE INSTRUCTIONS.
READ CAREFULLY
BEFORE ATTEMPTING
TO ASSEMBLE, INSTALL,
OPERATE OR MAINTAIN THE
PRODUCT DESCRIBED.**

**PROTECT YOURSELF AND
OTHERS BY OBSERVING ALL
SAFETY INFORMATION. FAILURE
TO COMPLY WITH INSTRUCTIONS
COULD RESULT IN PERSONAL
INJURY AND/OR PROPERTY
DAMAGE! RETAIN INSTRUCTIONS
FOR FUTURE REFERENCE.**

**PLEASE REFER TO BACK COVER
FOR INFORMATION REGARDING
DAYTON'S WARRANTY
AND OTHER IMPORTANT
INFORMATION.**

Model #: _____

Serial #: _____

Purch. Date: _____

GETTING STARTED

Save this manual

You will need this manual for the safety warnings and precautions, assembly instructions, operating and maintenance procedures, parts list and diagram. Keep your invoice with this manual. Write the invoice number on the inside of the front cover. Keep this manual and invoice in a safe and dry place for future reference.

Structural requirements



Make sure all supporting structures and load attaching devices are strong enough to hold your intended loads. If in doubt, consult a qualified structural engineer.

Electrical requirements



The power supply to your specific Disc Sander is determined by its model number. Model 9681314 requires 115V, 60Hz, 17.8 amps. Model 9681315 requires 230V, 60Hz, 11.2 amps single phase, Model 9681316 requires 230V, 60Hz, 5.2 amps three phase. Model 9681317 requires 430V, 60Hz, 3.0 amps three phase. The standard allowable voltage variation is a plus or minus 10%.

UNPACKING

When unpacking, check to make sure all parts listed below are included. If any parts are missing or broken, please contact your local retailer.

CAUTION *Never use highly volatile solvents. Avoid getting cleaning solution on paint as it may tend to deteriorate these finishes. Use soap and water on painted components.*

IMPORTANT: Many unpainted steel surfaces will have been coated with a protectant. To ensure proper fit and operation, remove the coating. Coating can be easily removed with mild solvents, such as mineral spirits and a soft cloth. Avoid getting solution on paint or any of the rubber/plastic parts. Solvents may deteriorate these finishes. Use soap and water on paint, plastic or rubber components. After cleaning, cover all exposed surfaces with a light coating of oil.

Contents:

- Disc Sander
- 5 mm Hex Wrench
- Miter Gauge
- Adhesive Backed Sanding Disc
- Anti-vibration Foot Pads

Unpack



Remove all the over packing materials, but leave unit attached to its pallet. Do not discard packing materials until after the machine has been inspected for damage and completeness. Locate loose parts and set them aside.

Inspect



- After unpacking the unit, carefully inspect for any damage that may have occurred during transit. Check for loose, missing or damaged parts. Shipping damage claims must be filed with the carrier.

- All tools should be visually inspected before use, in addition to regular periodic maintenance inspections.
- Be sure that the voltage labeled on the unit matches your power supply.

SAFETY RULES

WARNING *For your own safety, read all of the instructions and precautions before operating tool.*

WARNING *Always follow proper operating procedures as defined in this manual even if you are familiar with the use of this tool or similar machines. Remember that being careless for even a fraction of a second can result in severe personal injury.*



PROPOSITION 65 WARNING: Some dust created by using power tools contain chemicals known to the state of California to cause cancer, birth defects or other reproductive harm.

Some examples of these chemicals are:

- Lead from lead-based paints.
- Crystalline silica from bricks and cement and other masonry products
- Arsenic and chromium from chemically-treated lumber.

Your risk from these exposures varies, depending on how often you do this type of work. To reduce your exposure to these chemicals: work in a well ventilated area and work with approved safety equipment. Always wear a OSHA/NIOSH approved, properly fitting face mask or respirator when using such tools.

Preparing for your job

- Wear safety glasses complying with United States ANSI Z87.1. Everyday glasses only have impact resistant lenses. They are not safety glasses.
- Wear an ANSI approved dust mask.
- Wear proper apparel when using this tool. Do not wear loose clothing, gloves, neckties, rings, bracelets or other jewelry which may get caught up in moving parts of this machine.
- When using this machine, wear protective hair covering to contain long hair.
- Wear safety shoes with non-slip soles.
- Be alert and think clearly. Never operate power tools when tired, intoxicated or when taking medications that cause drowsiness.

Preparing the work area for your job

- Keep your work area clean. Cluttered work areas invite accidents.
- Do not set up or use the Disc Sander in dangerous environments. Do not set up or use the Disc Sander in damp or wet locations. Do not expose this machine to rain.
- Make sure your work area is properly lighted.
- Proper electrical connections should be set up for this machine.
- Extension cords should have a grounding prong and the

- three wires of the extension cord should be of the proper gauge.
- Keep visitors at a safe distance from work area.
- Keep children out of the workplace. Make your workshop childproof. Use padlocks, master switches or remove switch keys to prevent any unintentional use of your power tools.

Maintaining your tool

- Always unplug the tool and remove it from its power source prior to inspection. If your machine plugs into an electrical outlet do not unplug the tool by pulling on the cord.
- Consult this manual for specific maintenance and adjustment procedures.
- Keep the tool clean for safest operation. Metal or wood dust build ups can become combustible.
- Check for damaged parts. A part that is damaged should be properly repaired or replaced. Do not perform makeshift repairs. Use the parts list in this manual to order repair parts. Repairs must be made by a qualified technician.

Know how to use your tool

▲ WARNING *Dusty work environments may be hazardous to your health. Always wear a OSHA/NIOSH approved, properly fitting face mask or respirator.*

▲ WARNING *The operation of any machine can result in foreign objects being thrown into the eyes, which can result in severe eye damage. Always wear safety goggles complying with United States ANSI Z87.1. (shown on package) before commencing power tool operation.*

▲ CAUTION *Think safety! Safety is a combination of operator common sense and alertness at all times when tool is being used.*

- Know your tool. Learn the tool's operation, application and specific limitations.
- Keep your hands away from moving parts and sanding surfaces.

- Never operate the machine without the disc guards in place.
- Completely disconnect this machine from its power source when changing an abrasive disc.
- Use the right tool for the job. Do not force a tool or attachment to do a job for which it was not designed.
- To reduce the risk of electrical shock, never use the machine in rain or allow it to become wet.
- Never attach the Disc Sander to a dust extraction unit used for wood sanding if you are sanding metal. The sparks can cause a fire or explosion.
- Turn the tool off immediately in the case of an emergency. Completely remove the tool from its power source before attempting to fix the issue.
- Never leave tool running unattended. Turn the power off and do not leave tool until it comes to a complete stop.
- Do not use the tool as a toy or let children play with it. Care should be taken when using the tool around children or animals.
- Avoid accidental start-ups. Make sure that the power switch is in the OFF position before plugging the machine in or connecting it into an appropriate electrical resource.
- Do not overreach. Keep proper footing and balance.
- Never stand on the machine. Serious injury could occur if the tool tips or if the sanding disc is unintentionally contacted.
- Only use recommended accessories. The improper use of accessories may create a risk of operator injury.
- Handle workpieces correctly to help protect your hands from possible injury.
- Support your workpiece with the supplied miter gauge or the work table. Never "free-hand" sand a workpiece.
- Maintain a 1/16" maximum clearance or less between table and sanding disc.
- Follow OSHA lock-out, tag-out procedures to prevent accidental machine starts.

SPECIFICATIONS Disc Sanding Machines	Model 9681314 Disc Sander	Model 9681315 Disc Sander	Model 9681316 Disc Sander	Model 9681317 Disc Sander
Electrical requirements	115V, 60 Hz, single phase	220V, 60 Hz, single phase	220V, 60 Hz, three phase	440V, 60 Hz, three phase
Amps AC	12.5A	11.2A	9.1A	5.2A
Motor Size	1.5 HP	2 HP	3 HP	3 HP
Disc speed (RPM)	1720	1720	1720	1720
Sanding disc diameter	16"	20"	20"	20"
Table size (L x W)	18.58" x 8.5"	22.68" x 8.5"	22.68" x 8.5"	22.68" x 8.5"
Table tilt-in angle	5°	5°	5°	5°
Table tilt-out angle	45°	45°	45°	45°
Dust collection port diameter	4"	4"	4"	4"
Overall Dimensions (L x W x H)	27.84" x 23.33" X 44.44"	27.75" x 27.68" x 46.44"	27.75" x 27.68" x 46.44"	27.75" x 27.68" x 46.44"
Gross pkg. weight	266.76 lbs.	313.5 lbs.	313.5 lbs.	313.5 lbs.

Electrical connections

▲ WARNING *Make sure the tool is off before plugging it into a power source to prevent accidental starts.*

▲ WARNING *Do not permit fingers to touch the terminals of plug when installing or removing from outlet.*

Electrical safety

- Double insulated tools are equipped with a polarizing three pronged plug (one blade is wider than the other.) This plug will fit in a polarized outlet only one way. If the plug does not fit fully into the outlet, reverse the plug. If it still does not fit, contact a qualified electrician to install a polarized outlet. Do not change the plug in any way.
- Double insulation eliminates the need for the three wire grounded power cord and grounded power supply system. Before plugging in the tool, be certain the outlet voltage supplied is within the voltage marked on the nameplate.
- Avoid body contact with grounded surfaces such as pipes, radiators, ranges and refrigerators. There is an increased risk of electric shock if your body is grounded. If operating the power tool in damp locations is unavoidable, a Ground Fault Circuit Interrupter must be used to supply the power to your tool. Rubber soled footwear will further enhance your personal safety.
- 4. Don't expose this or any tools to rain or wet conditions. Water entering a power tool will increase the risk of electric shock.
- 5. Do not abuse the cord. Never pull on a cord to unplug it from an outlet. Keep the cord away from heat, oil, sharp edges or moving parts. Replace damaged cords immediately. Damaged cords increase the risk of electric shock.

Extension cords

- The use of an extension cord will cause some drop in voltage and loss of power.
- Wires of the extension cord must be of sufficient size to carry the current and maintain adequate voltage.
- Use the table to determine the minimum wire size (A.W.G) extension cord.
- Use only 3-wire extension cords having 3-prong grounding type plugs and 3-pole receptacles which accept the tool plug.
- If the extension cord is worn, cut or damaged in any way, replace it immediately.

Extension cord length

Wire Size	A.W.G.
Up to 25 ft	16
25 to 100 ft	14

NOTE: Using extension cords over 100 ft long is not recommended.

ASSEMBLY/INSTALLATION

▲ WARNING *This tool must be connected to or plugged into a properly grounded outlet. Never operate the machine if it is not properly grounded to help prevent electrical shock.*

Power source

- The motor on this machine is designed for operation on the voltage and frequency specified. Normal loads will be handled safely on voltages not more than 10% above or below specified voltage.
- Running the unit on voltages which are not within the range may cause overheating and motor burn-out. Heavy loads require that the voltage at the motor terminals be no less than the voltage specified.

Lifting and setting up the machine

1. Remove any crating or outer packing materials covering the machine. Leave the machine attached to its pallet.

NOTE: Disc sanding machines are heavy. Be certain any hoists or devices used to lift this machine are capable of handling the weight. The machine may tip as it is lifted.

You can minimize this tipping by rigging an additional slings over the machine as needed. Be careful when using a sling to prevent it from damaging any components on the machine. Carefully steady the machine to prevent it from spinning, but do not stand under the machine.

2. Remove all accessory items from the pallet or machine table. Compare these items with those listed on page 3.
3. The machine must be placed on a solid concrete floor away from any vibrations transmitted from adjacent machines. Unless substantially constructed, and braced a wood floor should be avoided.
4. Check all lock handles on the machine to ensure they are tight.
5. Remove any nuts, bolts or fasteners securing the machine to the pallet.
6. Center an overhead crane or other suitable lifting device and sling arrangement over the machine.
7. Carefully lift the machine off the pallet. Raise the machine no higher than necessary to clear the hold-down hardware and pull the pallet out of the way. **DO NOT** place your hands or feet underneath the machine when removing the pallet.
8. Place the machine into a final position on a flat surface allowing adequate space around the machine for workpieces and dust extraction connection. (see diagrams on pg. 6)
9. When the machine is being lowered into its final location, level it using the supplied anti-vibration feet.
10. Use a highly accurate spirit or laser level for leveling the machine. Leveling should be done on the top of the stand since this is the reference standard for both side-to-side and front-to-back leveling. It is important that the machine be properly leveled and for optimum performance.

ASSEMBLY/INSTALLATION (CONTINUED)

Lifting and setting up the machine

Shown below are the dimensions for the disc sanding machines. You can use the information below to place your machine into its final position. Also, allow extra space around the machine for the handling larger workpieces and dust extraction connections.

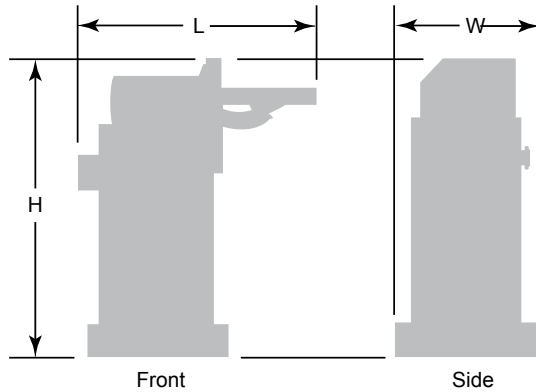

	Length	Width	Height
Model 9681314	27.84"	23.33"	44.44"
Model 9681315	27.75"	27.68"	46.44"
Model 9681316	27.75"	27.68"	46.44"
Model 9681317	27.75"	27.68"	46.44"

Attaching the sander to a dust extraction unit

⚠ WARNING *Never connect a disc sander being used for metal sanding to a wood dust extraction system. The sparks created from sanding metal can cause the wood sawdust to catch fire or explode.*

- Your disc sander machine can be attached to a dust extraction system to keep your work shop cleaner. Use of a dust extraction unit strongly recommended.

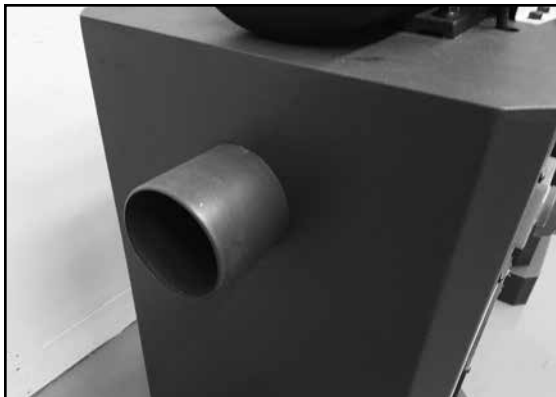

- This machine uses a 4" diameter dust port. Locate the dust port on the left side of the machine. Slide a suitable hose over the port and secure it with a hose clamp. Dryer vent hosing material is not acceptable.

OPERATION

⚠ WARNING *Dusty work environments may be hazardous to your health. Always wear a OSHA/NIOSH approved, properly fitting face mask or respirator.*

⚠ WARNING *Always wear safety glasses complying with U.S. ANSI Z87.1 before beginning any sanding operation.*

⚠ WARNING *Make sure all disc guards are in securely in place before starting the disc sanding machine. Never operate the machine without the guards.*

⚠ WARNING *Completely disconnect the disc sanding machine before making any adjustments or changing abrasive sanding discs.*

Installing an abrasive sanding disc

NOTE: While not required, it is much easier to make table alignment adjustments while the abrasive sanding disc is removed (see pg. 7).

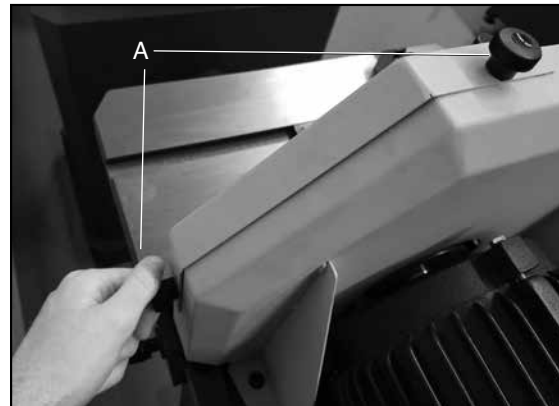

- Remove the two knobs (A) holding the upper disc guard in place.

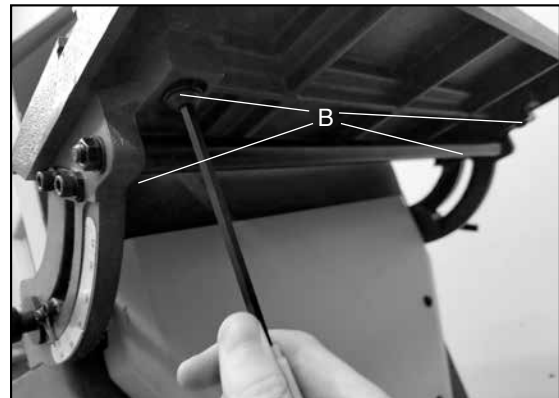

- Loosen and remove the four hex bolts (B) under the workpiece table using the supplied 5 mm hex wrench. Remove the workpiece table.

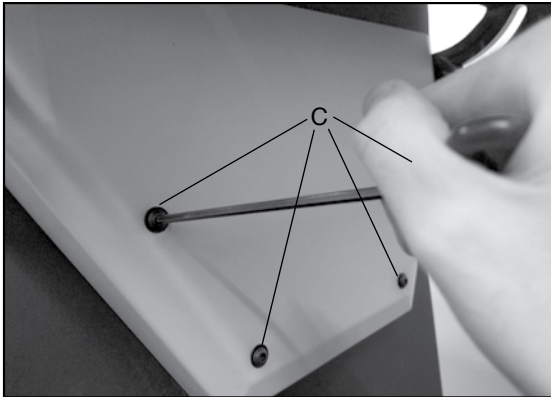

3. Use the supplied 4 mm hex wrench attached to the base to remove the four hex bolts (C) holding on the lower guard. Remove the lower guard.

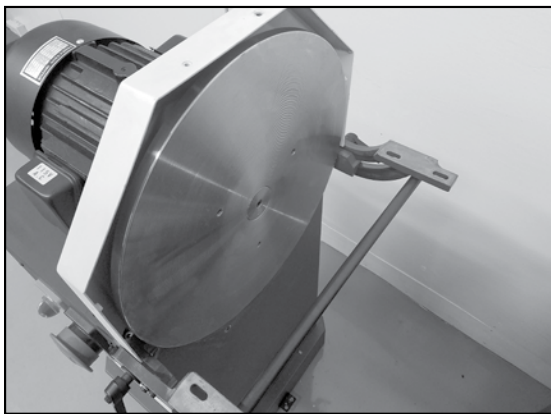

3. Remove the sanding disc from the flywheel disc.
4. Clean the flywheel disc of any left-over adhesive, dirt or grease.

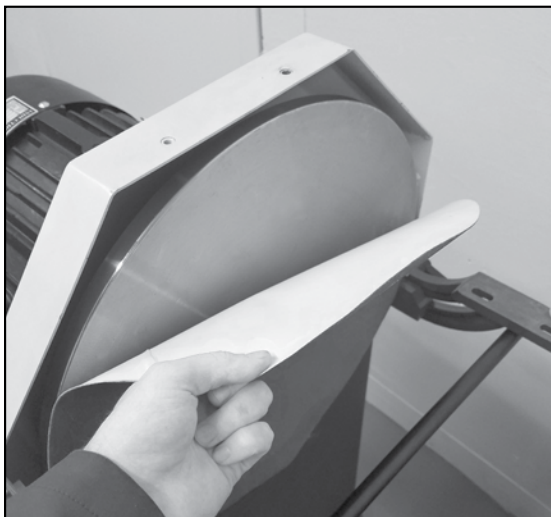

5. Remove the adhesive backing from the top half of the sanding disc. Aligning the bottom of the disc and adhere the top first. Then remove the bottom adhesive backing and adhere the bottom of the sanding disc. Take care to center the abrasive sanding disc on the flywheel disc.
6. After the new abrasive disc is attached, press firmly on it to ensure it is tightly adhered to the flywheel disc.
7. Replace the lower guard, table and upper guard.

Table parallel alignment to disc

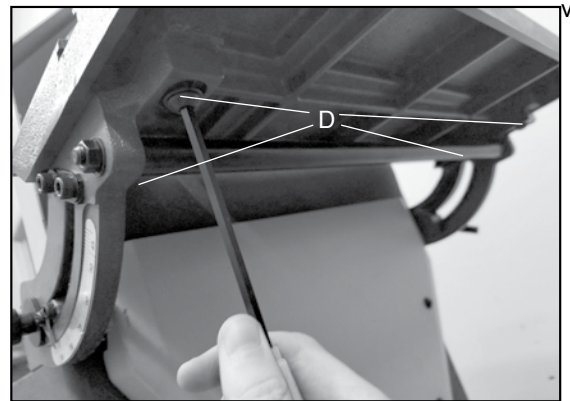

The workpiece table must be properly aligned to the sanding disc to ensure flush sanding. The table must be set to it does not touch the sanding disc and has a clearance gap of 1/16" or less. To set the table gap perform the following steps:

1. Loosen the four bolts under the miter brackets enough so the table can move.
2. Align the table so the gap between the disc and table is consistently 1/16" or less from front to back.
3. Tighten the four bolts making sure the table does not move during the process.

Setting the miter bracket to a 90° right angle

The workpiece table can be adjusted to ensure your disc sander performs accurate flush and angled miter sanding operations. To set a true 90° reference for your disc sander perform the following steps:

NOTE: While not required, it is much easier to make table alignment adjustments while the abrasive sanding disc is removed.

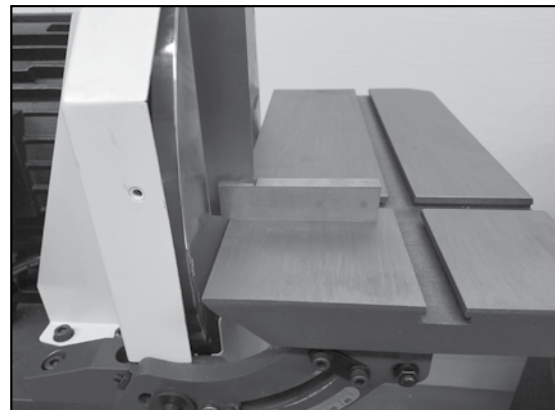

1. Slightly loosen the miter adjustment levers on both ends of the workpiece table so it can move.
2. Use a machinist square or suitable tool and adjust the table until the square rests flush on both the table and disc.
3. Carefully tighten the adjustment lever and recheck the table.
4. Adjust the indicator pointer to 90° if required.

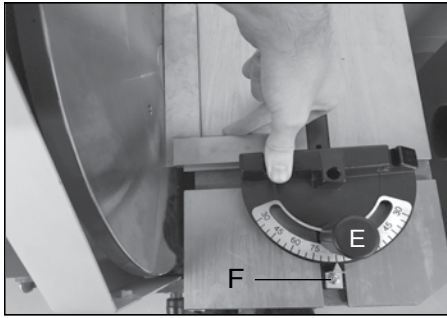

Setting the miter tool to a 90° right angle

The miter tool can be adjusted to ensure your disc sander performs accurate flush and angled miter sanding operations. To set a true 90° reference for miter tool, perform the following steps:

NOTE: While not required, it is much easier to adjust the miter tool while the abrasive sanding disc is removed.

1. Slightly loosen the miter tool adjustment push knob (E).
2. Use a machinist square or suitable tool and adjust the face of the miter tool until the square rests flush on both the miter tool face and flywheel disc.
3. Carefully tighten the adjustment push knob and recheck the miter tool to ensure it is square.
4. Adjust the indicator pointer (F) to 90° if required.

Turning on the sanding disc machine

1. Ensure the machine is properly connected to a suitable electrical supply, and the emergency stop button is pulled out.
2. Locate the power and direction switch to the left of the emergency stop button.

3. Turn the pointer from the middle OFF position to the left FOR position, and the disc will spin in the counter-clockwise motion.
4. The right REV position will rotate the disc in the clockwise direction.
5. To stop the machine, turn the pointer back the middle OFF position, or push the emergency stop button with either your hand or knee.

Setting the guards for forward or reverse rotation

It is recommended that you sand your workpiece with the disc rotating down toward the workpiece to hold it against the table.

The top disc guard can be moved to expose either the front or rear half of the sanding disc. Move the top guard by loosening and removing the two black knobs on the top and back (or front depending on the guard's set up). The guard's position is set according to the rotation of the sanding disc.

Counterclockwise rotation set up

To set up the machine for counterclockwise rotation, set the disc guard to the back portion of the disc.

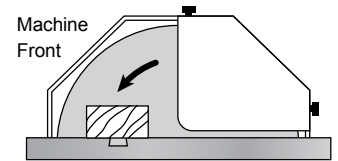

Clockwise rotation set up

To set up the machine for clockwise rotation set the disc guard to the front and sand on the back portion of the disc.

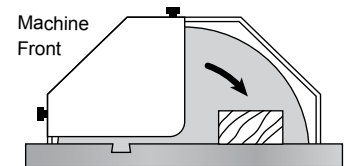

TROUBLESHOOTING GUIDE

Symptom	Possible Cause(s)	Corrective Action
Sanding paper becomes glazed.	Sanding a painted or coated surface.	Use open-end grain/flint sanding paper with a coarser grit.
	Wood is wet or gummy.	Use different material.
Burn marks on workpiece.	Wrong sanding paper surface.	Use coarser grit for stock removal.
	Forcing the workpiece into the sanding disc.	Do not force the workpiece into sanding disc. Allow the disc to cut freely.
Sanding paper burns, or clogs quickly.	Do not force the workpiece into sanding disc. Allow the disc to cut freely.	Make several passes instead of trying to remove large amounts of material in one pass.
Workpiece pulled from hand.	No support for workpiece. Do not free hand sand workpieces.	Use miter gauge. Keep workpiece firmly down against table.
Sanded edge is not square.	Result of freehand sanding. Free hand sanding is not recommended.	Keep workpiece flat on table at all times when a square edge is desired. Use miter gauge to ensure workpiece is square with sanding disc.
	Table scale inaccurate.	Check table alignment to disc with a machinist's square. It should be 90 degrees. Adjust pointer and table angle if necessary.

TROUBLESHOOTING GUIDE

Symptom	Possible Cause(s)	Corrective Action
Disc sander will not start or restart. Machine trips circuit breakers or blows fuses.	Disc sander is connected to an inappropriate power source.	Confirm disc sander is connected to power and source appropriate for the machine.
	Blown fuse or tripped circuit breaker	Replace blown fuse; reset circuit breaker.
	Cord damaged.	Replace damaged cord.
	Extension cord too light or too long.	Replace extension cord with one of adequate size for its length.
	Building fuse blows or circuit breaker trips.	Confirm the building's circuitry is large enough to accommodate the disc sander. Check for a loose electrical lead if circuitry is large enough.
	Electrical connections loose.	Check all electrical connections on the disc sander including the motor connections. Confirm each connection is tight. Visually check for signs of electrical arcing which indicates loose connections or circuit overload.
	Switch or motor failure (troubleshooting between the two).	Use a voltmeter to determine if the issue is a switch or motor failure. First, verify that the incoming voltage reads according to the rated voltage, and second, check the voltage between switch and motor. This voltage should also read according to rated voltage. If incoming voltage is incorrect, the issue is power supply problem. If voltage between switch and motor is incorrect, the issue is a switch problem. If voltage between switch and motor is correct, your issue is a motor problem.
	Motor failure.	If the electrical supply and switch show correct voltage, the motor is probably the issue. Have a qualified electrician test the motor for function. Replace motor as needed.
Disc does not come up to full speed.	On/Off switch failure.	Have a qualified electrician test the switch to ensure it is functioning properly. Replace switch as needed
	Extension cord too light or too long.	Replace extension cord with one of adequate size for its length.
	Low voltage being supplied to the machine.	Have a qualified electrician address the issue.
Excessive replacement of sanding paper.	Excessive sanding friction or feed pressure is too great.	Do not force the workpiece into sanding disc. Allow the disc to cut freely.
	Excessive pressure being used during sanding operations.	Do not force the workpiece into sanding disc. Allow the disc to cut freely.
Machine vibrates excessively.	Not using full width of disc.	Stroke across the full width of the sanding disc.
	Sander base not level with floor.	Level the machine using the supplied anti-vibration feet.
Sanding marks on workpiece.	Motor loose or improper motor mounting.	Check and adjust motor mounting. Confirm all motor mounting bolts are tight.
	Sanding disc is too coarse based on the material being sanded.	Use proper grit disc. Coarser grits remove stock quicker and leave a rougher finish. Finer grits show less marks and are used for finishing work.
Sanding granules quickly rub off the sanding disc.	Workpiece sanded across grain.	When surface sanding, use fine sanding disc paper then finish by hand, working in direction of grain.
	The sanding disc has lost its original properties or is defective.	Never store sanding discs in extremely dry or high-temperature areas which can damage the glue holding the granules. Never fold sanding discs, store them flat.

WIRING DIAGRAM - MODEL 9681314 - 16" DISC SANDER

Black : B
White : W
Green : G

Single Phase Switch

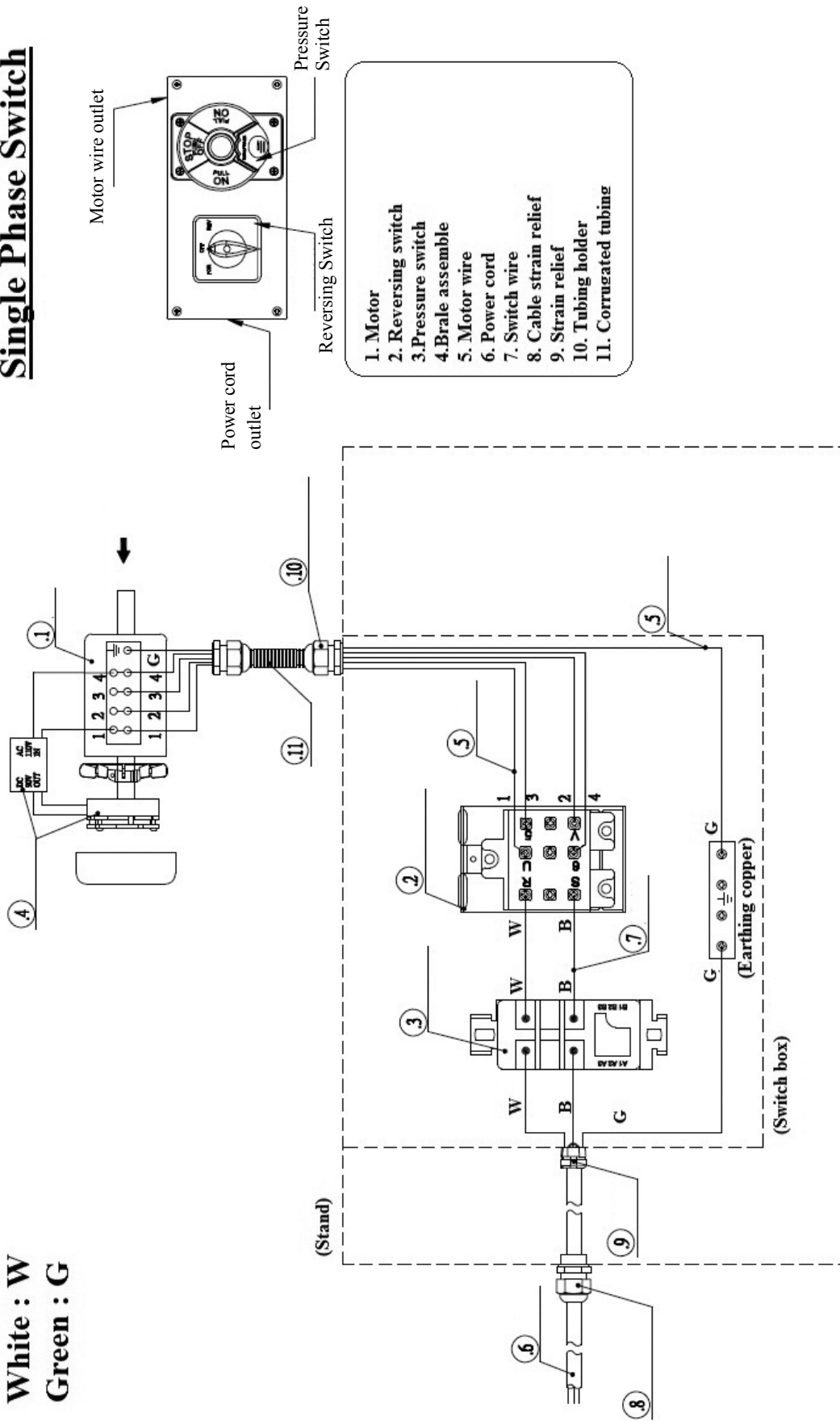

WIRING DIAGRAM - MODEL 9681315 - 20" DISC SANDER

Single Phase Switch

Black : B
White : W
Red : R
Green : G

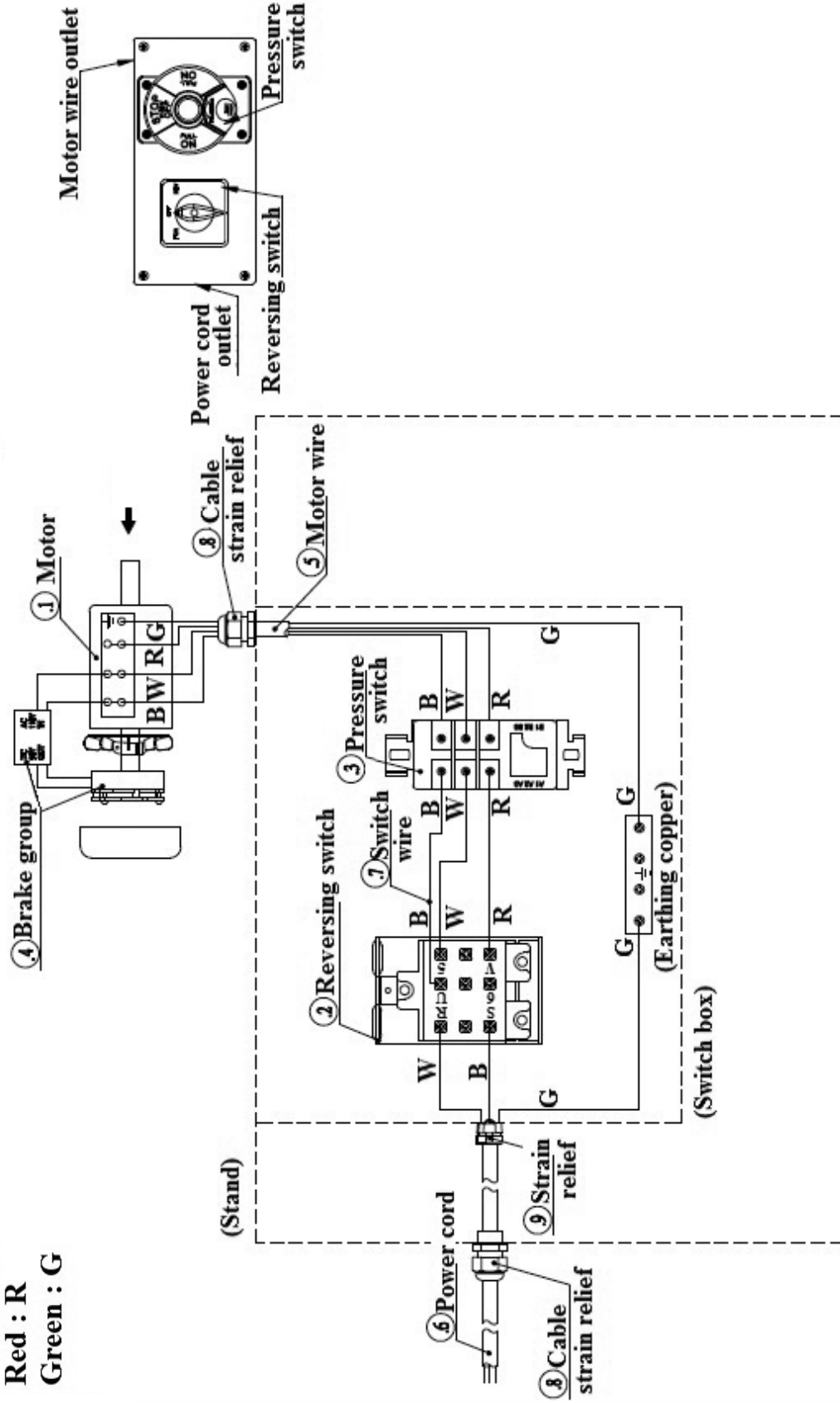

WIRING DIAGRAM - MODEL 9681316 - 20" DISC SANDER

Three Phase Switch

Black : B
White : W
Red : R
Green : G

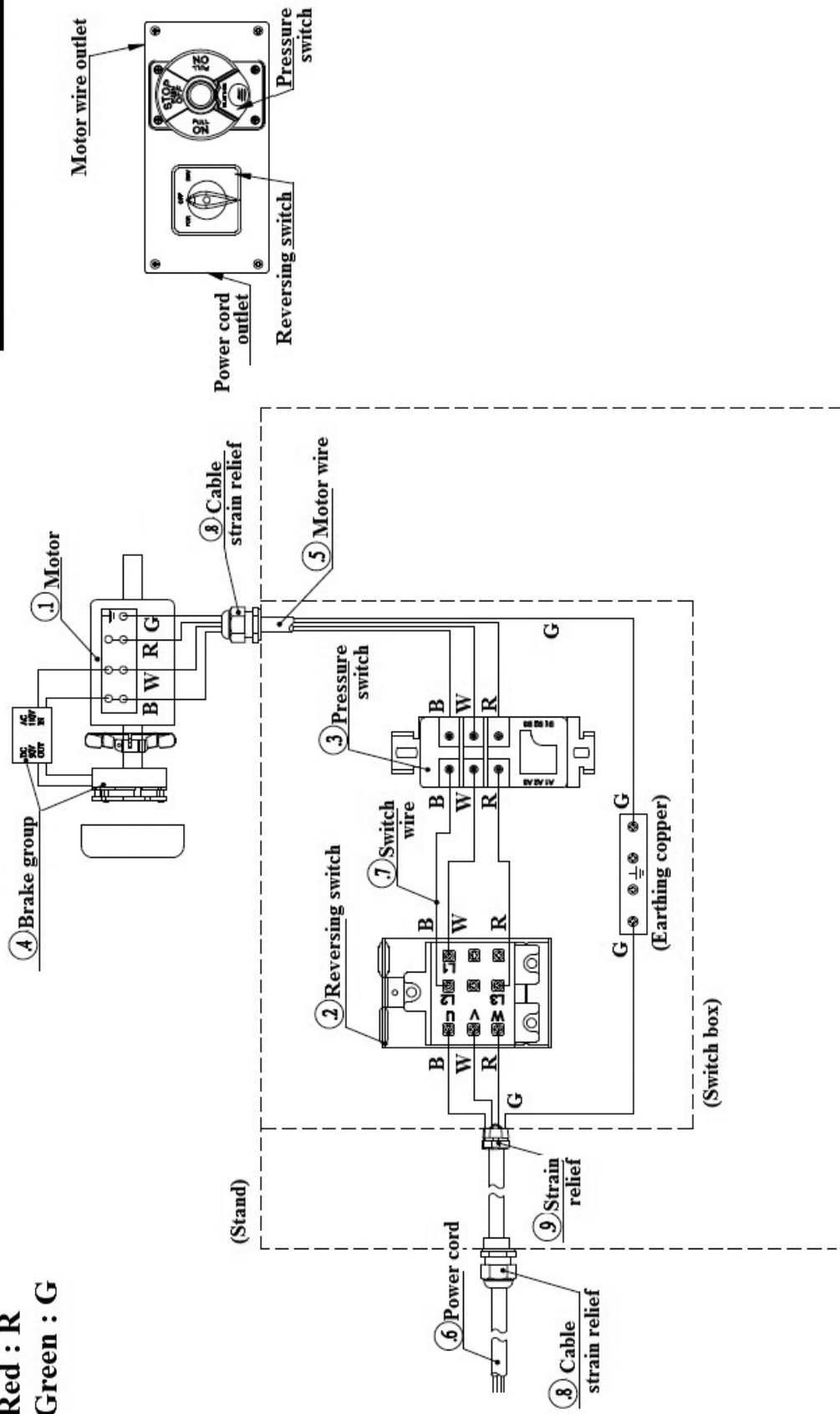

REPAIR PARTS ILLUSTRATION FOR MODEL 9681314 - 16" DISC SANDER

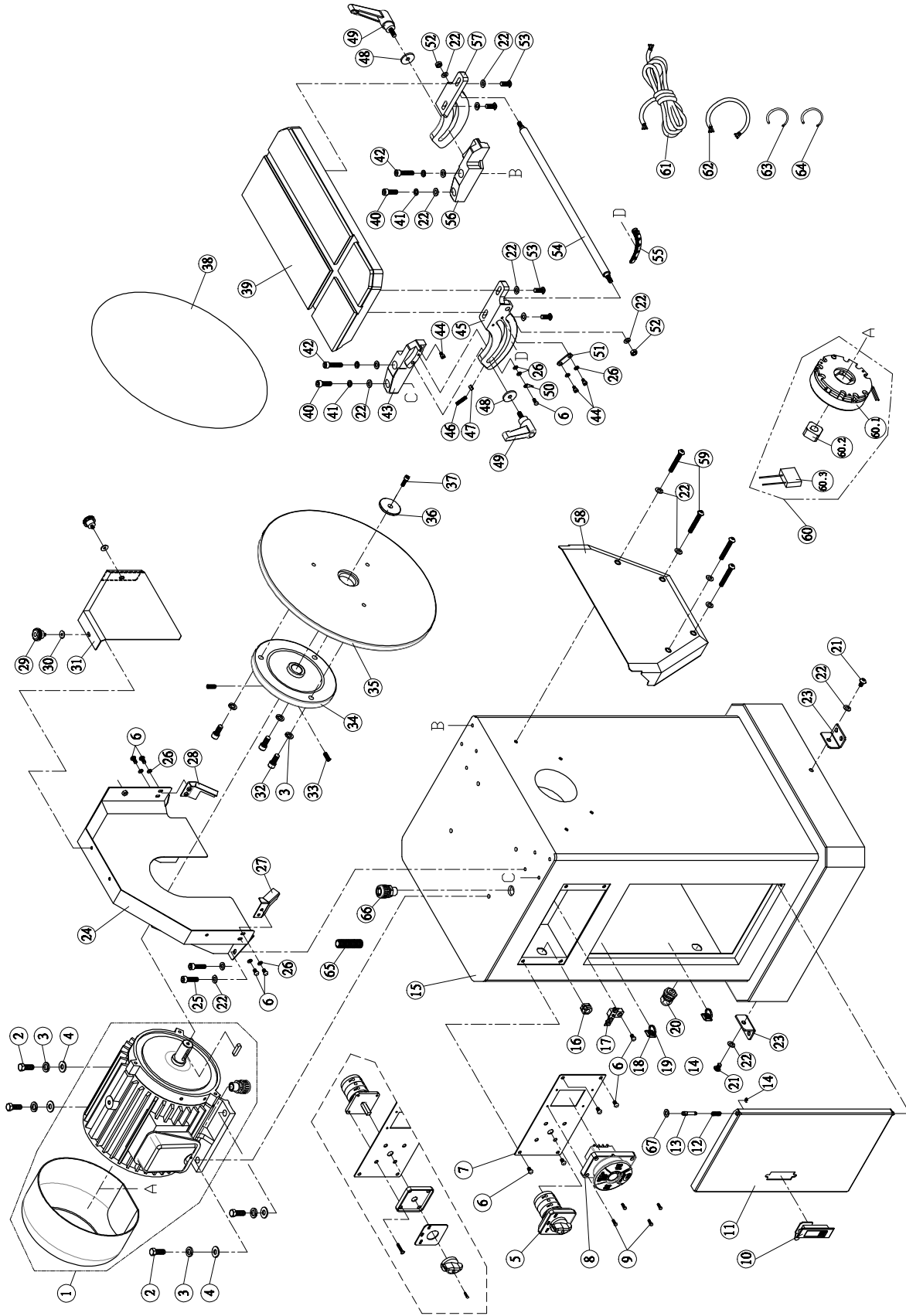

Please provide following information:
 -Model number
 -Serial number (if any)
 -Part description and number as shown in parts list

For Repair Parts, call 1-800-827-3398

REPAIR PARTS LIST FOR MODEL 9681314 - 16" DISC SANDER

Ref. No.	Description	Part No.	Qty.
1	Motor (1.5HP, 115V, 60Hz, 1PH, 4P)	9642598.01	1
2	Hex Screw (M10 x 1.5P x 25L)	*	4
3	Spring Washer (M10)	*	7
4	Flat Washer (10.2 x 23 x 2t)	*	4
5	Reversing Switch	9642599.01	1
6	Round Head Screw (M5 x 1.0P x 12L)	*	10
7	Switch Mount	9642600.01	1
8	Pressure Switch (125V/35A 250V/20A)	9642601.01	1
9	Round Head Screw (M4 x 0.7P x 12L)	*	4
10	Door Buckle	9642602.01	1
11	Door	9642603.01	1
12	Spring	9642604.01	1
13	Pin	9642605.01	1
14	E ring (ETW-4)	*	1
15	Stand	N/A	1
16	Strain Relief (SB8R-3)	*	1
17	Ground Copper (3P)	9642606.01	1
18	Bracket	9642607.01	2
19	Wire Holder (ALT-165S 2.5Wx160L)	9642608.01	2
20	Cable Strain Relief (PG-13.5)	9642653.01	2
21	Round Head Screw (M8 x 1.25 x 12L)	*	3
22	Flat Washer (8.2 x 16 x 1t)	*	19
23	Anti-vibration Pad Bracket	9642609.01	3
24	Disc Guard	9642610.01	1
25	Cap Screw (M8 x 1.25 x 10L)	*	4
26	Flat Washer (5.1 x 10 x 1t)	*	8
27	Dust Chute Plate, Left	9642611.01	1
28	Dust Chute Plate, Right	9642612.01	1
29	Knob	9642613.01	2
30	Flat Washer (5.2 x 16 x 1.4t)	*	2
31	Disc Guard, Front	9642614.01	1
32	Cap Screw (3/8"-16 UNC x 7/8"L)	*	3
33	Set Screw (5/16"-18 UNC x 3/4"L)	*	2
34	Hub	9642615.01	1
35	16" Disc	9642616.01	1
36	Wheel Washer	9642617.01	1
37	Cap Screw (1/4"-20 UNC x 3/4"L)	*	1
38	Abrasive Disc	*	1
39	Table	9642619.01	1
40	Cap Screw (M8 x 1.25P x 30L)	*	2
41	Spring Washer (M8)	*	4
42	Cap Screw (M8 x 1.25P x 35L)	*	2
43	Trunnion Bracket, Left	9642620.01	1
44	Cap Screw(M5 x 0.8P x 8L)	*	3
45	Trunnion, Left	9642621.01	1
46	Set Screw (M6 x 1.0P x 25L)	*	1
47	Hex Nut (M6 x 1.0P)	*	1
48	Flat Washer (8 x 30 x 3t)	*	2
49	Adjustment Knob (M8 x 1.25P x 20L)	9642622.01	2

Ref. No.	Description	Part No.	Qty.
50	Pointer	9642623.01	1
51	Angle Adjustment Plate	9642624.01	2
52	Hex Nut (M8 x 1.25P)	*	2
53	Round Head Screw (M8 x 1.25 x 20L)	*	4
54	Tie Rod	9642625.01	1
55	Angle Scale	9642626.01	1
56	Trunnion Bracket, Right	9642627.01	1
57	Trunnion, Right	9642628.01	1
58	Dust Chute	9642629.01	1
59	Round Head Screw (M8 x 1.25 x55L)	*	4
60	Brake Assembly	9642630.01	1
60.1	Brake (9CB-18E)	9642631.01	1
60.2	Brake Block	9642632.01	1
60.3	Rectifier (IN:AC110V/OUT:DC90V)	9642633.01	1
61	Motor Wire (14AWGx4Cx45cm)	9642634.01	1
62	Power cord (SJT 14AWG x 3C x 300cm + 110V(CSA))	9642635.01	1
63	Switch Wire (14AWG x 2C x 20cm)	9642636.01	1
64	Ground Cord ((600V) 14AWG x 1Cx60cm)	9642637.01	1
65	Hose NGN-12B 3/8" x 8cm	9642638.01	1
66	Strain Relief (N-MGN20-15B-ST M20 x 1.5P)	*	2
67	Foam washer	*	1

(Δ) Not Shown (*) Standard hardware item available locally (N/A) Not available as replacement part

GETTING STARTED

SAFETY / SPECIFICATIONS

ASSEMBLY / INSTALLATION

OPERATION

TROUBLESHOOTING

MAINTENANCE / REPAIR

REPAIR PARTS ILLUSTRATION FOR MODELS 9681315, 9681316 AND 9681317 - 20" DISC SANDERS

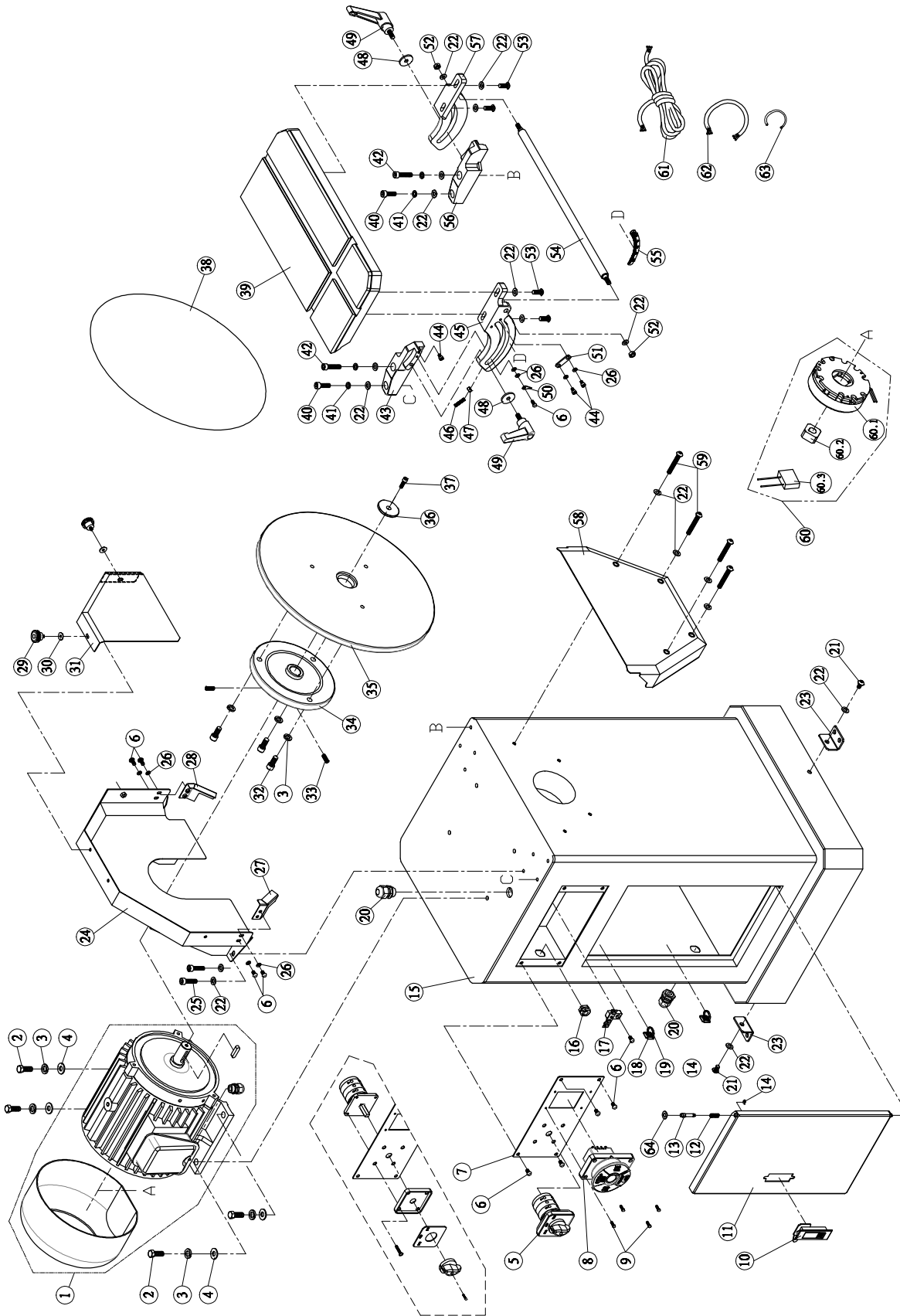

Please provide following information:
 -Model number
 -Serial number (if any)
 -Part description and number as shown in parts list

For Repair Parts, call 1-800-827-3398

REPAIR PARTS LIST FOR MODEL 9681315, 9681316 AND 9681317 - 20" DISC SANDERS

Ref. No.	Description	Part No.	Qty.
1	Motor Model 9681315 (2HP, 230V, 60Hz, 1PH)	9642642.01	1
1	Motor Model 9681316 (3HP, 230V, 60Hz, 3PH)	9642641.01	1
1	Motor Model 9681317 (3HP, 460V, 60Hz, 3PH)	9642685.01	1
2	Hex Screw (M10 x 1.5P x 25L)	*	4
3	Spring Washer M10)	*	7
4	Flat Washer (10.2 x 23 x 2t)	*	4
5	Reversing Switch	9642643.01	1
6	Round Head Screw (M5 x 1.0P x 12L)	*	10
7	Switch Mount	9642644.01	1
8	Pressure Switch	9642645.01	1
9	Round Head Screw (M4 x 0.7P x 12L)	*	4
10	Door Buckle	9642602.01	1
11	Door	9642603.01	1
12	Spring	9642604.01	1
13	Pin	9642605.01	1
14	E Ring (ETW-4)	*	1
15	Stand	N/A	1
16	Strain Relief (SB8R-3)	*	1
17	Earthing copper (3P)	9642606.01	1
18	Bracket	9642607.01	2
19	Wire Holder (ALT-165S 2.5W x 160L)	9642608.01	2
20	Cable Strain Relief (PG-13.5)	9642653.01	2
21	Round Head Screw (M8 x 1.25 x 12L)	*	3
22	Flat Washer (8.2 x 16 x 1t)	*	19
23	Anti-vibration Pad Bracket	9642609.01	3
24	Disc Guard	9642655.01	1
25	Cap Screw (M8 x 1.25P x 10L)	*	4
26	Flat Washer (5.1 x 10 x 1t)	*	8
27	Dust Chute Plate, Left	9642656.01	1
28	Dust Chute Plate, Right	9642657.01	1
29	Knob	9642613.01	2
30	Flat Washer (5.2 x 16 x 1.4t)	*	2
31	Disc Guard, Front	9642659.01	1
32	Cap Screw (3/8"-16 UNC x 7/8"L)	*	3
33	Set Screw (5/16"-18 UNC x 3/4"L)	*	2
34	Hub	9642615.01	1
35	20" Disc	9642661.01	1
36	Disc Washer	9642617.01	1
37	Cap Screw (1/4"-20UNC x 3/4"L)	*	1
38	Abrasive Disc (20"#100)	*	1
39	Table	9642663.01	1
40	Cap Screw (M8 x 1.25P x 30L)	*	2
41	Spring Washer (M8)	*	4
42	Cap Screw (M8 x 1.25P x 35L)	*	2
43	Trunnion Bracket, left	9642620.01	1
44	Cap Screw (M5 x 0.8P x 8L)	*	3

Ref. No.	Description	Part No.	Qty.
45	Trunnion, Left	9642621.01	1
46	Set Screw (M6 x 1.0P x 25L)	*	1
47	Hex Nut (M6 x 1.0P)	*	1
48	Flat Washer (8 x 30 x 3t)	*	2
49	Adjustment Knob (M8 x 1.25P x 20L)	9642622.01	2
50	Pointer	9642623.01	1
51	Angle Adjustment Plate	9642624.01	2
52	Hex Nut (M8 x 1.25P)	*	2
53	Round Head Screw (M8 x 1.25 x 20L)	*	4
54	Tie Rod	9642669.01	1
55	Angle Scale	9642626.01	1
56	Trunnion Bracket, Right	9642627.01	1
57	Trunnion, Right	9642628.01	1
58	Dust Chute	9642673.01	1
59	Round Head Screw (M8 x 1.25 x 55L)	*	4
60	Brake Assembly	9642674.01	1
60.1	Brake (CB-18E)	9642675.01	1
60.2	Brake Block	9642632.01	1
60.3	Rectifier (IN:AC220V/OUT:DC90V)	9642677.01	1
61	Motor Wire	9642678.01	1
62	Power Cord	9642679.01	1
63	Switch Wire	9642680.01	1
64	Foam Washer	*	1

(Δ) Not Shown (*) Standard hardware item available locally (N/A) Not available as replacement part

GETTING STARTED

SAFETY / SPECIFICATIONS

ASSEMBLY / INSTALLATION

OPERATION

TROUBLESHOOTING

MAINTENANCE / REPAIR

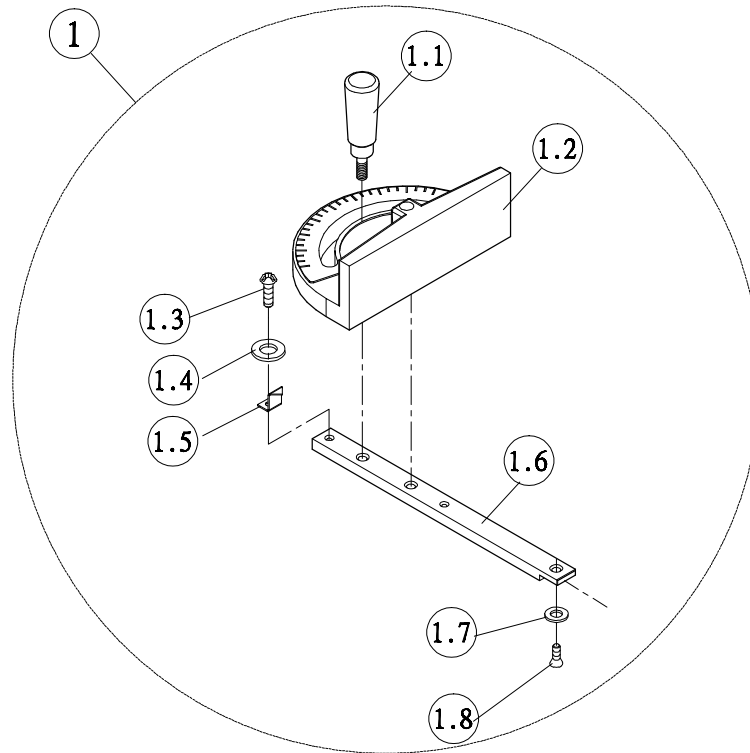
**REPAIR PARTS ILLUSTRATION FOR MITER GAUGE,
 MODELS 9681314, 9681315 AND 9681316 - DISC SANDERS**

For Repair Parts, call 1-800-827-3398

Please provide following information:

- Model number
- Serial number (if any)
- Part description and number as shown in parts list

REPAIR PARTS LIST FOR MITER GAUGE - 9681314, 9681315, 9681316 AND 9681317 - DISC SANDERS

Ref. No.	Description	Part No.	Qty.
1	Miter Gauge Assembly	9642639.01	1
1.1	Handle	N/A	1
1.2	Miter Gauge	N/A	1
1.3	Round Head Screw (3/16"-24 UNC x 5/16"L)	N/A	1

Ref. No.	Description	Part No.	Qty.
1.4	Flat Washer (95.1 x 12 x 1.0t)	N/A	1
1.5	Pointer	N/A	1
1.6	Bar	N/A	1
1.7	Washer	N/A	1
1.8	Phillips Screw (1/4"-20 UNC x 5/16"L)	N/A	1

GETTING STARTED

SAFETY / SPECIFICATIONS

ASSEMBLY / INSTALLATION

OPERATION

TROUBLESHOOTING

MAINTENANCE / REPAIR

(Δ) Not Shown (*) Standard hardware item available locally (N/A) Not available as replacement part

PALMGREN WARRANTY

C.H. Hanson / Palmgren warrants their products to be free of defects in material or workmanship. This warranty does not cover defects due directly or indirectly to misuse, abuse, normal wear and tear, failure to properly maintain the product, heated, ground or otherwise altered, or used for a purpose other than that for which is was intended.

The warranty does not cover expendable and/or wear part (i.e. v-belts, screws, abrasives, jaws), damage to tools arising from alteration, abuse or use other than their intended purpose, packing and freight. The duration of this warranty is expressly limited to the terms noted below beginning from the date of delivery to the original user.

The Palmgren branded items carry the following warranties on parts:

All vises, clamps, positioning tables, tombstones, jack screws and vise accessories - LIFETIME.

All bench grinders, drill presses, tapping machines, band saws, lathes, milling machines, arbor presses, abrasive finishing machines and work stands - 3 YEARS.

The obligation of C.H. Hanson / Palmgren is limited solely to the repair or replacement, at our option, at its factory or authorized repair agent of any part that should prove inoperable. Purchaser must lubricate and maintain the product under normal operating conditions at all times. Prior to operation become familiar with product and the included materials, i.e. warnings, cautions and manuals.

Failure to follow these instructions will void the warranty.

This warranty is the purchaser's exclusive remedy against C.H. Hanson for any inoperable parts in its product. Under no circumstances is C.H. Hanson liable for any direct, indirect, incidental, special or consequential damages including loss of profits in any way elated to the use or inability to use our products. This warranty gives you specific legal rights which may vary from state to state.



Palmgren - a C.H. Hanson Company
2000 N. Aurora Rd., Naperville, IL 60540 U.S.A.
or call 1-800-827-3398