

CODE NUMBER

3980095

DESCRIPTION

1.6 gpf, Polished Chrome Finish, 1.5" Flush Connection, Fixture Connection Top Spud, Single Flush, 1" Inlet, 1" Control Stop, True Mechanical Override, Battery, Infrared, Regal® Exposed Sensor Water Closet Flushometer.

DETAILS

- Flush Volume: 1.6 gpf (6.0 Lpf)
- Finish: Polished Chrome (CP)
- Power Type: Battery
- Battery Life: 3 years
- Valve: Diaphragm
- Valve Body Material: Semi-red Brass
- Fixture Type: Water Closet
- Fixture Connection: Top Spud
- Rough-In Dimension: 11 ½" (292mm)
- Spud Coupling: 1 ½" (38mm)
- Supply Pipe: 1" (25mm)
- Override: True Mechanical (TMO)
- Control Stop: 1"
- Inlet: 1"
- Flush Connection: 1.5"

FEATURES

- Four (4) size C batteries included
- "Low Battery" Flashing LED
- "User in View" Flashing LED
- No External Volume Adjustment to Ensure Water Conservation
- True Mechanical Override Flush Button
- 72-Hour Sentinel Flush
- Sweat Solder Adapter w/Cover Tube and Cast Wall Flange with Set Screw
- Stop Seat and Vacuum Breaker Molded from PERMEX® Rubber Compound for Chloramine resistance
- 1" I.P.S. Screwdriver Bak-Chek® angle stop with stop plug



COMPLIANCES & CERTIFICATIONS



(ADA Compliant, BAA Compliant, BABAA Compliant, cUPC Certified, UPC Certified)

RECOMMENDED SPECIFICATION

Valve Body, Cover, Tailpiece and Control Stop shall be in conformance with ASTM Alloy Classification for Semi- Red Brass. Valve shall be in compliance with the applicable sections of ASSE 1037 and ANSI/ASME 112.19.2.

ELECTRICAL SPECIFICATIONS

- Battery Life: 3 years
- Flush Delay: 3s
- Sensor Range: 22" - 42" (559-1,067mm)

VALVE OPERATING PRESSURE (FLOWING)

15-80 PSI (103-552 kPa). Specific fixtures may require greater minimum flowing pressure - consult manufacturer requirements.

DOWNLOADS

- [EBV-500/550-A Installation Instructions](#)
- [EL-700/750-A Installation Instructions](#)
- [Regal XL Exposed Installation Instructions](#)
- [Regal XL Exposed \(SP\) Installation Instructions](#)
- [Control Stop Repair and Maintenance Guide](#)
- [Flush Connections Flanges Repair and Maintenance Guide](#)
- [Tail Piece Repair and Maintenance Guide](#)
- [Regal Flushometers Repair and Maintenance Guide](#)
- [EBV500/EBV550 Repair and Maintenance Guide](#)
- [Additional Downloads](#)

NOTES

All information contained within this document subject to change without notice.

Looking for other variations of the REGAL 111 SFSM product? [View the general spec sheet with all options.](#)

Sloan 10500 Seymour Ave, Franklin Park, IL 60131

Phone: 800.982.5839 • Fax: 800.447.8329 • sloan.com

Battery life varies according to actual usage and restroom conditions.

WARRANTY

[View Warranty Information](#)

ROUGH-IN

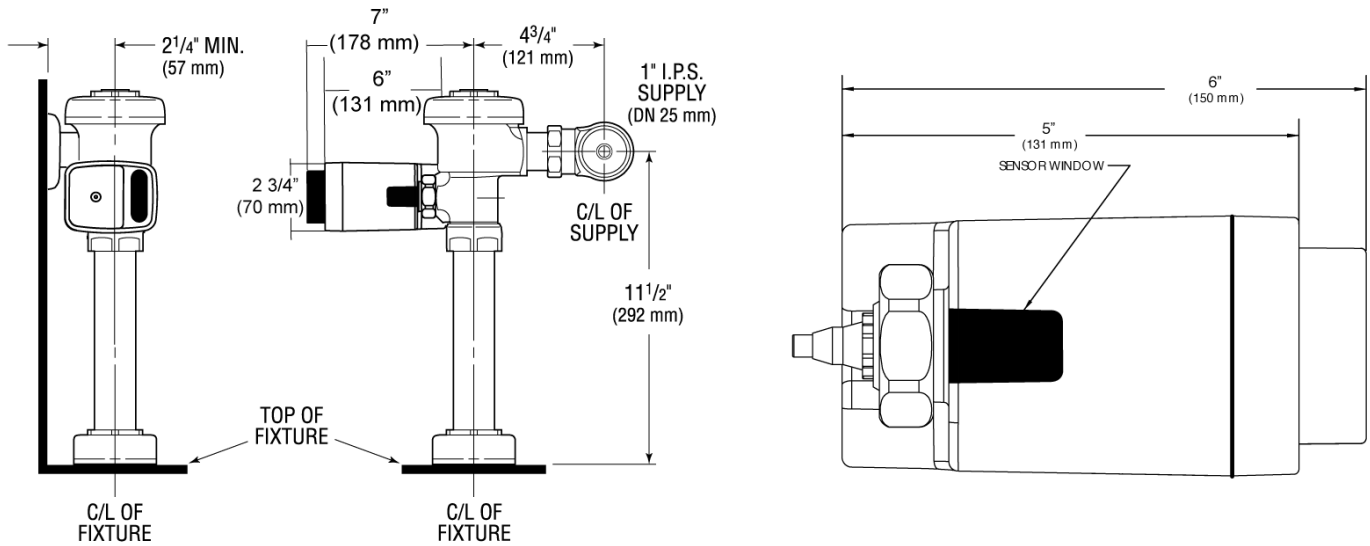

Sloan 10500 Seymour Ave, Franklin Park, IL 60131

Phone: 800.982.5839 • Fax: 800.447.8329 • sloan.com