



FLEXSTEEL®

W1147-841

### Upholstered Arm Chair

**IMPORTANT NOTE**

Carefully remove all the parts from the carton and put them individually on a soft cloth to prevent damage to the parts.

We have taken great care in the design of this product and request that you carefully and strictly follow our assembly instructions to ensure a completed product as it was designed.

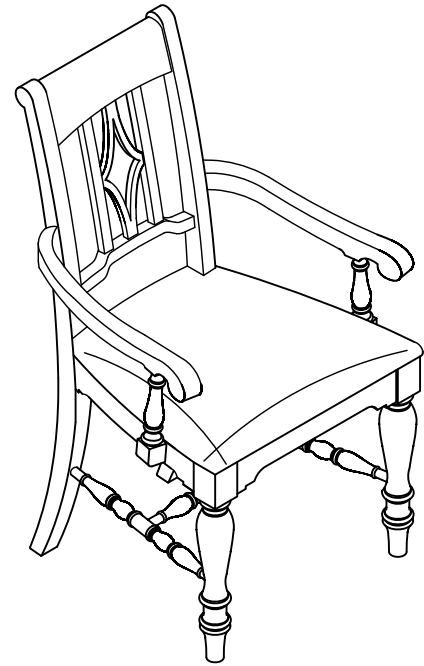

#### Part List

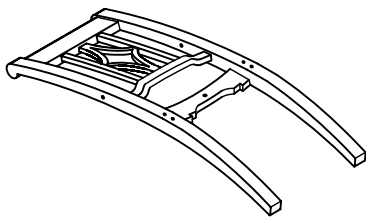

A. Backrest  
1 piece

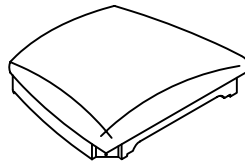

B. Seat Frame  
1 piece



C. Left/Right Front Leg  
2 pieces

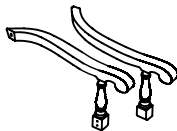

D. Left/Right Side Facing Arm  
2 pieces



E. Side Facing Stretcher  
2 pieces



F. Middle Stretcher  
1 piece

#### Hardware List

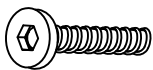

Short Bolt  
Φ1/4"\*40mm  
6 pieces



Medium Bolt  
Φ5/16"\*50mm  
5 pieces



Long Bolt  
Φ5/16"\*76mm  
4 pieces



Short Screw  
#8\*25mm  
2 pieces



Long Screw  
#8\*32mm  
4 pieces



Small Flat Washer  
Φ1/4"\*16\*1.5mm  
4 pieces



Small Spring Washer  
Φ1/4"  
6 pieces



Large Flat Washer  
Φ5/16"\*19\*1.5mm  
9 pieces



Large Spring Washer  
Φ5/16"  
9 pieces



Wood Plug  
Φ14\*10mm  
2 pieces



Hex Key  
60\*25\*4mm  
1 piece

Tool(s) recommended for assembly: Screwdriver



### IMPORTANT

- Do not tighten up all the screws until each part is properly assembled.
- You should keep Hex Key in a safe place as you may need to tighten up the bolts in the future.
- Use a soft cloth between these parts and the floor.
- 2 people recommended to make assembly process easier.

### STEP 1

Attach both front legs (C) to Seat Frame (B) using Large Flat Washer, Large Spring Washer and Medium Bolts (50mm) in 4 locations. Insert hardware a few threads and leave loose until Step 5 to prevent damage to wood. (See Figure 1)

### STEP 2

Lay the Backrest (A) flat on a soft cloth. Due to the design of the cushion, angle the assembled frame (B) when inserting into the Backrest (A) for proper fitment. DO NOT INSTALL HARDWARE YET. (See Figure 2)

### STEP 3

Insert both Side Facing Stretchers (D) to the Front Leg (C) and Backrest (A). Insert the Middle Stretcher (E). IMPORTANT: Once all pieces are fitted together in the proper location, Insert the 4 Long Screws (30mm) to secure the Side Facing Stretchers to the Front and Rear Legs. Insert the 2 Short Screws (25mm) to secure the Middle Stretcher. Secure the 6 screws. (See Figure 3.)

### STEP 4

Secure the Backrest (A) and Seat Frame (B) using Large Flat Washer, Large Spring Washer and Long Bolt (76mm) in all 4 side locations. (See Figure 4.)

### STEP 5

Secure the Backrest (A) and Seat Frame (B) using Large Flat Washer, Large Spring Washer and Medium Bolt (50mm) in the middle location. (See Figure 5.)

After all pieces are fitted together, fully tighten all Short, Medium and Long Bolts to achieve proper stability.

Figure 1

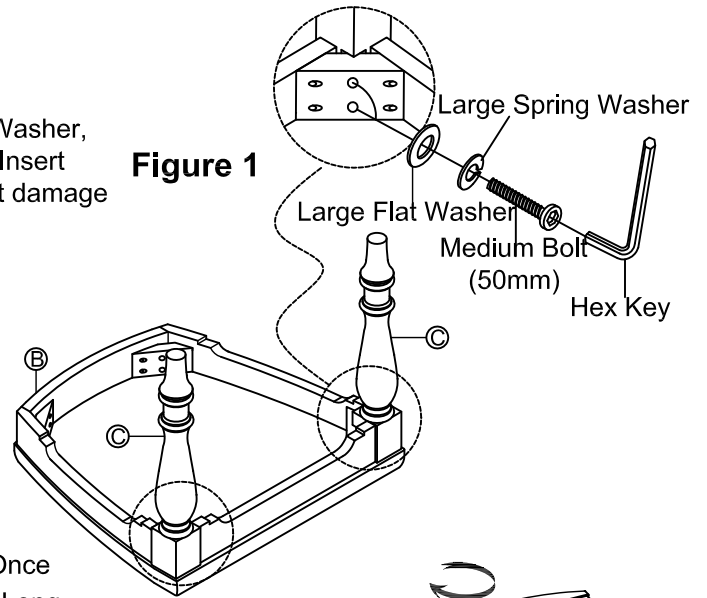

Figure 2

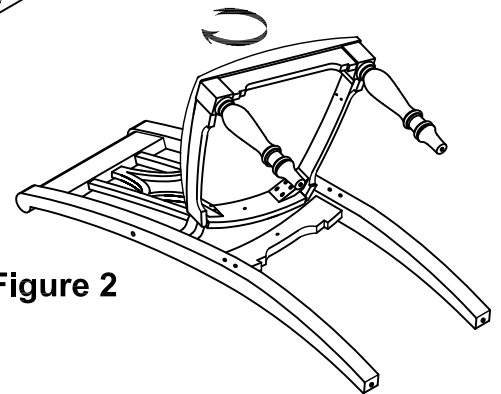

Figure 4

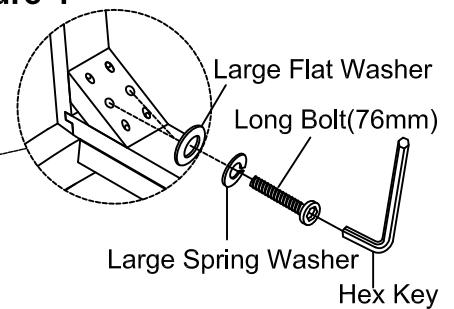

Figure 3

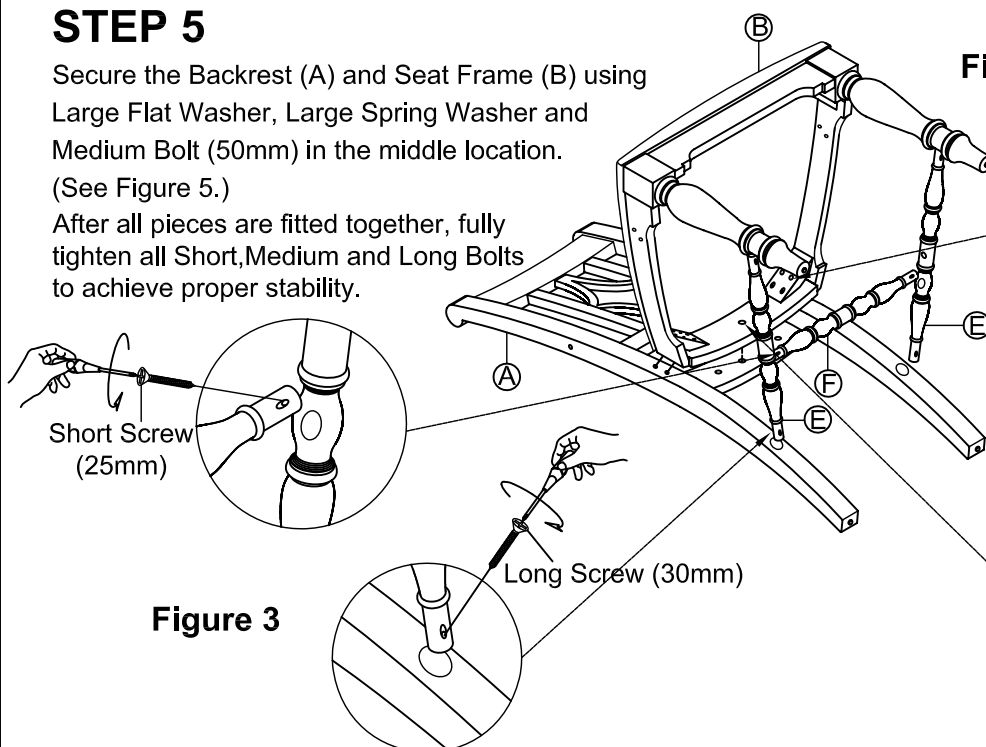
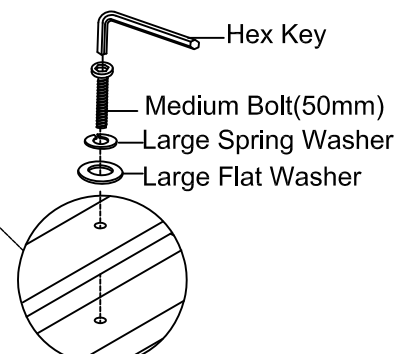

Figure 5





## STEP 6

Attach the Left/Right Side Facing Arm (D) to the Seat Frame (B) by inserting Small Flat Washer, Small Spring Washer, Short Bolt(mm) and tighten with Hex Key.  
(See Figure 6.)

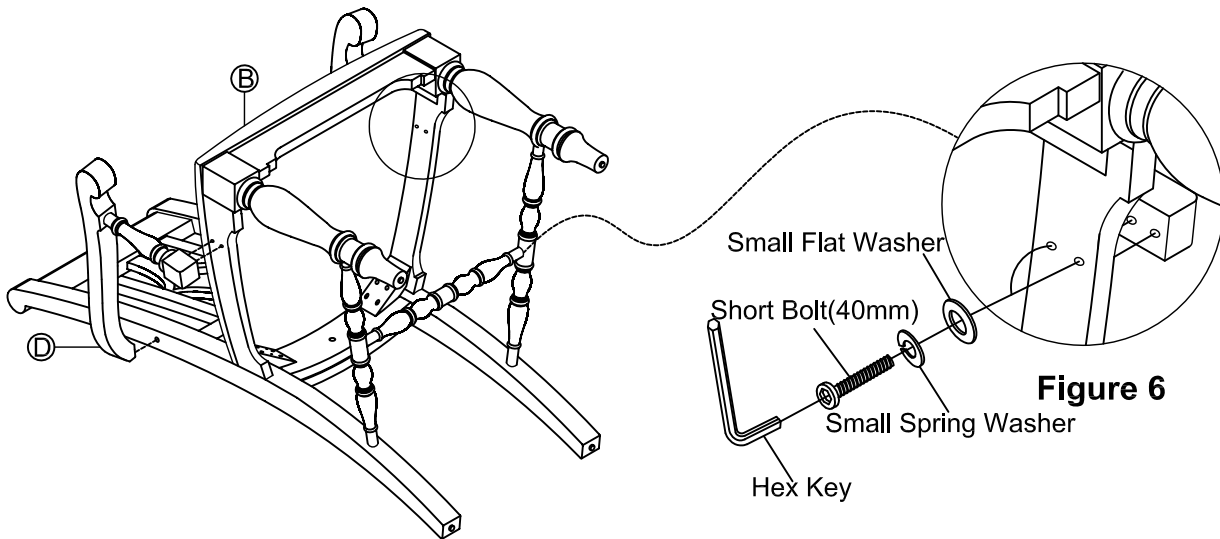

## STEP 7

Attach the Left/Right Side Facing Arm (D) to the Backrest (A) by inserting Small Spring Washer, Short Bolt(40mm) and tighten with Hex Key. Use the wood plug to cover the bolt hole.  
(See Figure 7.)

