



Project \_\_\_\_\_  
 Item # \_\_\_\_\_  
 Quantity \_\_\_\_\_

**SPECTRUM**  
**Commercial Electric**  
**Chamber Vacuum Packing Machine**

Model: EVPM-12

The SPECTRUM CHAMBER VACUUM PACKING MACHINE is ideal for food preservation, marinating, saving pre-cooked food and more. Food retains moisture, nutrition, and flavor when air is removed.



EVPM-12



**Standard Features**

- ◆ Compact design with large 3-gallon capacity vacuum chamber
- ◆ Dry vacuum pump and easy-to-use touch controls with adjustable vacuum & seal times, or instant-seal function
- ◆ Stainless steel construction
- ◆ Heavy-duty transparent lid; dome adds to chamber height
- ◆ Single one-piece 11-1/2" seal bar with bag clamp
- ◆ One year parts and labor warranty

**Parts**

EVPM-P1	Seal Bar Assembly
EVPM-P2	Sealing Ring
EVPM-P3	Up-down Piston Assembly
EVPM-P4	Power Board
EVPM-P5	Water Inlet Valve
EVPM-P6	Vacuum Pump
EVPM-P7	Vacuum Gauge
EVPM-P8	Membrane Switch
EVPM-P9	Control Board
EVPM-P10	Main Board
EVPM-P11	Small Solenoid Valve
EVPM-P12	Microswitch Assembly

**Accessories**

ESV-BH	Stainless Steel 3-Ring Bag Holder Stand
--------	---

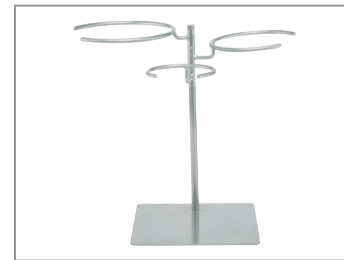

ESV-BH

**Winco®, DWL International Trading, LLC**

**New Jersey Headquarters:**  
 65 Industrial Road, Lodi, NJ 07644  
 Tel. 1.888.946.2682 | Fax: 1.888.946.2632

**California Distribution Center**  
 14950-14952 Valley View Avenue, La Mirada, CA 90638  
 Tel. 1.888.946.2652 | Fax: 1.562.926.5678

**Florida Distribution Center**  
 10800 NW 103rd St. Bldg 22, Ste 11, Miami, FL 33178  
 Tel. 1.786.536.4656

www.wincous.com | equipmentsales@wincous.com



# Commercial Electric Chamber Vacuum Packing Machine

Model: EVPM-12

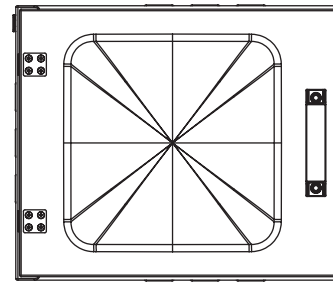

TOP VIEW

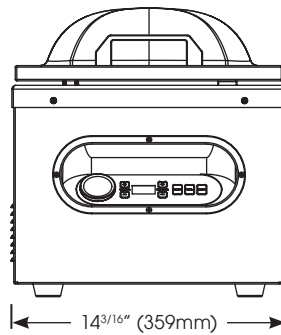

FRONT VIEW

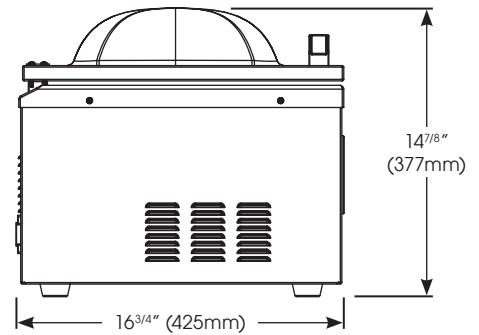

SIDE VIEW

## Specifications

MODEL	DESCRIPTION	OVERALL DIMENSIONS			VOLTS	HZ	WATTS	AMPS	PLUG	SHIP WEIGHT
		LENGTH	DEPTH	HEIGHT						
EVPM-12	Chamber Vacuum Sealer	14-3/16" (359mm)	16-3/4" (425mm)	14-7/8" (377mm)	110-120	60	630	5.25	NEMA 5-15P	59.7 lbs (27.1 kgs)
		CHAMBER DIMENSIONS								
		LENGTH	DEPTH	HEIGHT						
		12" (300mm)	13-7/8" (350mm)	4-5/16" (110mm)						
		SEAL BAR		SEAL WIRE						
11-1/2" (295mm)		5/16" (7.9mm)								

### Cord Location

On back right side

### Plug Configuration

NEMA 5-15P

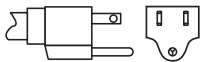

### Product Specs

#### Spectrum Commercial Electric Vacuum Sealer

The Commercial Electric Chamber Vacuum Packaging Machine model ESVC-28, as manufactured by Winco®, Lodi, NJ 07644.

The Commercial Electric Vacuum Sealer shall be rated at 630 Watts, 110-120V-60Hz.

ESVC-28 shall be equipped with a large 3-gallon capacity vacuum chamber, dry vacuum pump, and easy-to-use touch controls with adjustable vacuum & seal times, and instant-seal function. Units have stainless steel construction and a heavy-duty transparent lid with domed top that adds to the chamber height. The single one-piece seal bar measures 11-1/2"L and has a bag clamp.

The optional stainless steel 3-Ring Bag Holder Stand (ESV-BH, sold separately) conveniently holds various sizes of vacuum-packing bags open for easy filling.

ETL listed for safety (Canada & US) and sanitation.

Warranty consists of one year parts and labor.

Winco®, DWL International Trading, LLC

www.wincous.com | equipmentsales@wincous.com

**New Jersey Headquarters:**  
65 Industrial Road, Lodi, NJ 07644  
Tel. 1.888.946.2682 | Fax: 1.888.946.2632

**California Distribution Center**  
14950-14952 Valley View Avenue, La Mirada, CA 90638  
Tel. 1.888.946.2652 | Fax: 1.562.926.5678

**Florida Distribution Center**  
10800 NW 103rd St. Bldg 22, Ste 11, Miami, FL 33178  
Tel. 1.786.536.4656