

A

B

C

D

E

F

## REVISIONS

REV.	DESCRIPTION	DATE	APPROVED
A	INITIAL RELEASE	12/02/2004	
B	STUD BALL DIA REVISED	04/08/2005	
C	REVISED PART (700883)	1/14/2013	

1

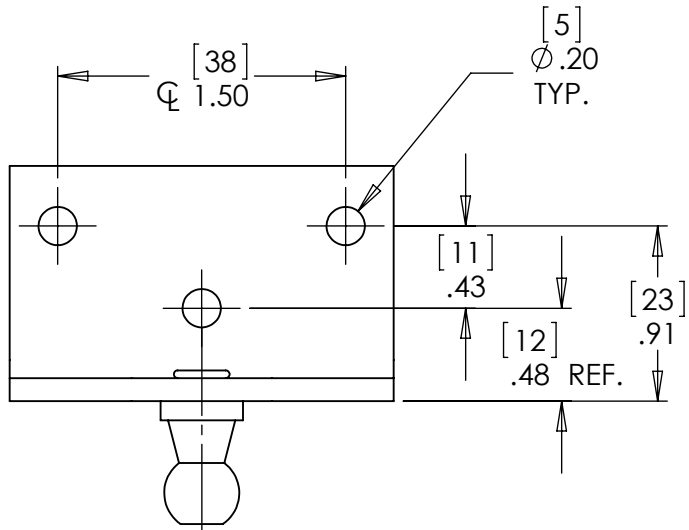

2

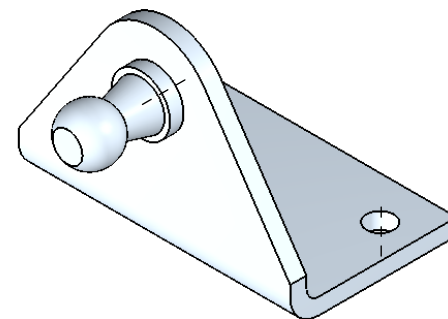

1

3

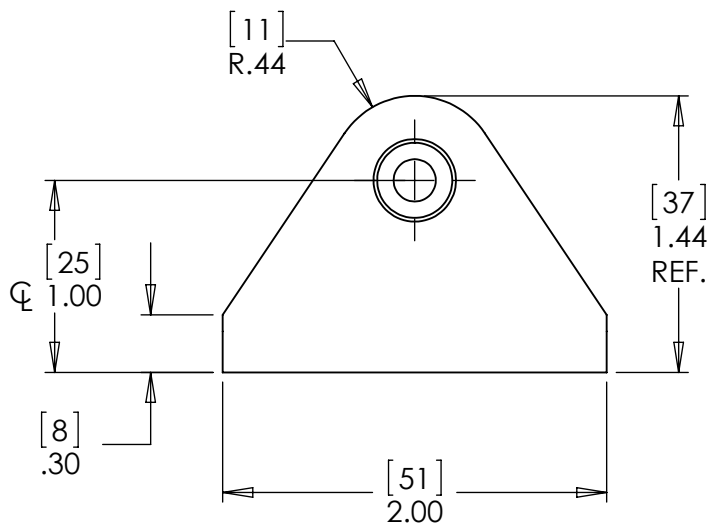

3

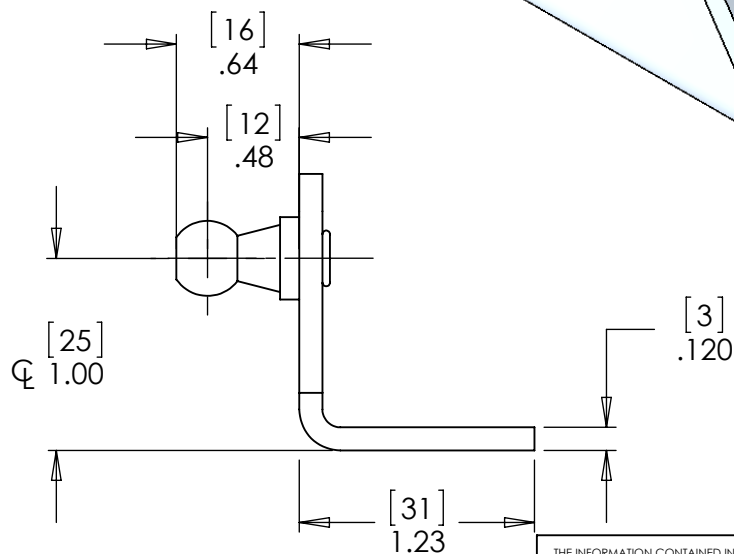

2

3

4

## NOTES:

- ALL DIMENSIONS ARE IN INCHES [MILLIMETERS]
- MATERIAL: STEEL
- FINISH: BRIGHT ZINC PLATE

THE INFORMATION CONTAINED IN THIS DRAWING IS THE SOLE PROPERTY OF TRANS CONTINENTAL HARDWARE. ANY REPRODUCTION IN PART OR AS A WHOLE WITHOUT THE WRITTEN PERMISSION OF TRANS CONTINENTAL HARDWARE IS PROHIBITED.

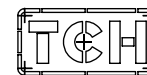

TRANS CONTINENTAL HARDWARE

PART NAME: **10MM - 3-HOLE RT ANGLE BRACKET**MATERIAL: **STEEL**DRAWING NO.: **530-102800**DATE: **12/2/2004** SCALE: **1:1** THIRD ANGLE PROJECTION DRAWING

ALL DIMENSIONS WITHOUT TOLERANCES ARE REFERENCE

SPECIFICATION SUBJECT TO CHANGE WITHOUT NOTICE

REVISION NO.

A

B

C

D

E

F

4