

UNIVERSAL[®] SECURITY INSTRUMENTS

Combo Smoke/CO Alarm Instruction Manual

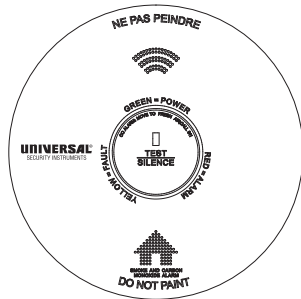

Model No.: USI/SMCO/10YR/V
USI/SMCO/10YR/V/2
RD-(886-H02)-39-001



Intertek
5019856



Thank you for purchasing this Combination Smoke/CO alarm USI/SMCO/10YR/V or USI/SMCO/10YR/V/2. This model is powered by non-replaceable internal lithium battery. It also contains a voice message system and silent control to temporarily silence nuisance alarms. THIS EQUIPMENT SHOULD BE INSTALLED IN ACCORDANCE WITH THE NATIONAL FIRE PROTECTION ASSOCIATION'S STANDARD 72

(National Fire Protection Association, Batterymarch Park, Quincy, MA 02169-7471).

Typical installation drawing layouts for the device(s) indicating recommended locations and wiring methods which shall be in accordance with the applicable requirements outlined in the following

1. National Electrical Code, NFPA 70, Wiring Methods and Materials;
2. National Fire Alarm and Signaling Code, NFPA 72, Single and Multiple-Station Alarms and Household Fire Alarm Systems for US requirement.

The National Fire Protection Association (NFPA) and the manufacturer recommend replacing this alarm ten years from the date code on back of the alarm, beyond which the device might no longer detect carbon monoxide accurately and should be immediately replaced. This instruction manual contains important information on starting operation and using the device.

ATTENTION! Please take a few minutes to thoroughly read the instruction manual and familiarize yourself and your family with its operation. And save it for future reference.

Supplier's Declaration of Conformity:

47 CFR § 2.1077 Compliance Information

Responsible Party: Feit Electric Company, Inc.

4901 Gregg Road, Pico Rivera, CA 90660, USA

www.feit.com

Unique Identifier: USI/SMCO/10YR/V

USI/SMCO/10YR/V/2

Images are representative only. Actual product may vary slightly.

Table of Contents

1. Smoke Alarm: Steps To Take When The Alarm Sounds
2. Carbon Monoxide Alarm: Steps To Take When The Alarm Sounds
3. Product Safety Information
4. Product Features and Specifications
5. Where to Install Smoke and Carbon Monoxide Alarms
6. Installation Locations To Avoid
7. Installation Instructions
8. Battery Function
9. Alarm Operation And Testing
10. Alarm Visual and Audible Indicators
11. Troubleshooting
12. Carbon Monoxide (CO) Overview
13. Good Safety Habits: Develop An Escape Plan
14. How to Identify Nuisance Alarms
15. Maintenance Information
16. Warranty Information

1. Smoke Alarm: Steps To Take When The Alarm Sounds

Smoke alarm pattern is three long beeps with voice "Fire!", "Incendie!", three long beeps, 1.5 seconds pause, repeating. The red LED flashes in sync with the alarm pattern exclusively on the alarm(s) that detected the hazard (initiating alarm).

The smoke alarm takes precedence when both smoke and carbon monoxide are present.

What to Do in Case of a Fire

1. Stay Calm: Don't panic. Take a deep breath and stay as calm as possible.
2. Exit Quickly: Leave the house right away. Before opening any door, carefully touch it to see if it's hot. If it is, use another exit. Crawl low to the ground to avoid smoke and don't stop to grab anything.
3. Meet Outside: Go to a pre-arranged meeting spot outside where everyone knows to gather.
4. Call for Help: Once you're outside, call the fire department or 911.
5. Stay Out: Never go back into a burning house. Wait for the fire department to arrive and help.

Note: These steps are to help keep you safe in case of a fire. However, it's equally important to prevent fires by practicing fire safety habits at home and avoiding hazardous situations.

2. Carbon Monoxide Alarm: Steps To Take When The Alarm Sounds

Carbon monoxide (CO) alarm pattern is four quick beeps with voice "Warning! Carbon Monoxide", "Attention! monoxyde de carbone!", four quick beeps, 5 seconds pause, repeating. The red LED flashes in sync with the alarm pattern exclusively on the alarm(s) that detected the hazard (initiating alarm).

WARNING! Actuation of your CO alarm indicates the presence of carbon monoxide (CO) which can kill you.

IF THE ALARM SOUNDS:

- 1). Pressing the TEST/SILENCE button on the alarming unit will silence the alarm notification. If the unit re-alarms within 6 minutes, it is sensing high levels of CO which can quickly become a dangerous situation.
- 2) Call your emergency services (Telephone Number) [fire department or 911];
- 3) Immediately move to fresh air – outdoors or by an open door/window. Do a head count to check that all persons are accounted for. Do not reenter the premises nor move away from the open door/window until the emergency services responders have arrived, the premises have been aired out, and your alarm remains in its normal condition.
- 4) After following steps 1 – 3, if your alarm reactivates within a 24 hour period, repeat steps 1 – 3 and call a qualified appliance technician (Telephone Number) to investigate for sources of CO from fuel burning equipment and appliances, and inspect for proper operation of this equipment. If problems are identified

during this inspection have the equipment serviced immediately. Note any combustion equipment not inspected by the technician and consult the manufacturers' instructions, or contact the manufacturers directly, for more information about CO safety and this equipment. Make sure that motor vehicles are not, and have not been, operating in an attached garage or adjacent to the residence.

NOTE: See Section HOW TO IDENTIFY NUISANCE ALARMS, for nuisance alarm situations.

3. Product Safety Information

WARNING! - PLEASE READ CAREFULLY AND THOROUGHLY.

- THIS PRODUCT IS INTENDED FOR USE IN ORDINARY INDOOR RESIDENTIAL AREAS. IT IS NOT DESIGNED TO MEASURE COMPLIANCE WITH COMMERCIAL AND INDUSTRIAL STANDARDS.
- Installation of the alarm should not be used as a substitute for proper installation, use and maintenance of fuel burning appliances including appropriate ventilation and exhaust systems.
- Smoke alarms are not to be used with smoke alarm guards unless the combination has been evaluated and found suitable for that purpose.
- This combo smoke/CO alarm requires a continuous supply of electrical power – it will not work without power.
- Individuals with medical problems may consider using warning devices which provide audible and visual signals for carbon monoxide concentrations under 30 ppm. This alarm has not been investigated for carbon monoxide detection below 70 PPM.
- There are situations where a smoke alarm may not be effective to protect against fire as stated in the NFPA Standard 72. For instance:
 - a. Fires where the victim is intimate with a flaming initiated fire; for example, when a person's clothes catch fire while cooking;
 - b. Fires where the smoke is prevented from reaching the smoke alarm due to a closed door or other obstruction;
 - c. Incendiary fires where the fire grows so rapidly that an occupants egress is blocked even with properly located smoke alarms.
- This product is intended for use in ordinary indoor locations of family living units. It is not designed to measure compliance with Occupational Safety and Health Administration (OSHA) commercial or industrial standards.
- This Combo Smoke/CO alarm is designed to detect carbon monoxide gas from any source of combustion. It is not designed to detect any other gas.
- This Combo Smoke/CO alarm will not protect against the risk of smoke or carbon monoxide poisoning when the battery has drained.
- This device should be installed by a qualified professional.
- THIS DEVICE WILL ONLY INDICATE THE PRESENCE OF CARBON MONOXIDE GAS AT THE SENSOR. CARBON MONOXIDE GAS MIGHT BE PRESENT IN OTHER AREAS.
- IT IS NOT DESIGNED FOR USE IN A RECREATIONAL VEHICLE (RV) OR BOAT.

WARNING! - THIS DEVICE IS DESIGNED TO PROTECT INDIVIDUALS FROM THE ACUTE EFFECTS OF CARBON MONOXIDE EXPOSURE. IT WILL NOT FULLY SAFEGUARD INDIVIDUALS WITH SPECIFIC MEDICAL CONDITIONS. IF IN DOUBT CONSULT A MEDICAL PRACTITIONER.

- The TEST/SILENCE button accurately tests the device functions. Do not use any other test method. Test the device weekly to ensure proper operation. Do not install in non-residential buildings. And the device is not a substitute for a complete alarm system.
- If you're sure activation isn't a real alarm, open windows or fan the air around the device to silence it.
- Observe and follow all local and national electrical and building codes for installation.
- This Combo Smoke/CO alarm is designed to be used inside a single family only. In multifamily homes, each individual living unit should have its own smoke alarm devices.
- Install a Combo Smoke/CO alarm in every room and on every level of the home. Smoke may not reach the smoke alarm for many reasons. For example, if a fire starts in a remote part of the home, on another level, in a chimney, wall, roof, or on the other side of a closed door, smoke may not reach the device in time to alert household members. This Combo Smoke/CO alarm will not promptly detect a fire or CO danger except in the area or room in which it is installed.
- This Combo Smoke/CO alarm may not alert every household member every time. The alarm horn is loud in order to alert individuals to a potential danger. However, there may be some circumstances where a household member may not hear the alarm (i.e. outdoor or indoor noise, sound sleepers, drug or alcohol usage, the hard of hearing, etc.). If you suspect that this device may not alert a household member, should install and maintain other specialty smoke alarm or/and CO alarm devices. Household member must hear the alarm's warning sound and quickly respond to it to reduce the risk of damage, injury, or death that may result from fire. If a household member is hard of hearing, install other special smoke alarm and/or CO alarm with lights or vibrating devices to alert occupants.
- This Combo Smoke/CO alarm can only sound their alarms when they detect smoke or detect combustion particles or dangerous level of CO in the air. They do not sense heat, flame, or other gas. The device is designed to give audible warning of a developing fire. However, many fires are fast - burning, explosive, or intentional, and others are caused by carelessness or safety hazards. In these cases, smoke may not remake the unit alarm QUICKLY ENOUGH to ensure safe escape.
- This Combo Smoke/CO alarm has limitations. The device is not foolproof and is not warranted to protect lives or property from fire. Smoke alarm or/and CO alarm are not a substitute for insurance. Homeowners and renters should insure their lives and property. In addition, it is possible for the device to fail at any time. For this reason, you must test the device weekly and replace every 10 years.

4. Product Features and Specifications

Model: USI/SMCO/10YR/V

USI/SMCO/10YR/V/2

Product standards:

Conf. to UL STD 217 & 2034

Power Supply: CR17450 Lithium Battery

Sensor of Smoke: Multi-Criteria Optical

Smoke Alarm Sensitivity: 2.08%/ft +/-25% OBS

Smoke Alarm Silence: About 8 minutes

CO Silence: About 5 minutes

Sensor of CO: Electrochemical

Voice message system CO alarm sensitivity Setting (Conforms to UL2034):

70PPM Between 60 to 240 minutes

150PPM Between 10 to 50 minutes

400PPM Between 4 to 15 minutes

Product Life: 10 years after manufacture

Temperature Operating Range: 40°F (4.4°C) to 100°F (37.8°C)

Humidity Operating Range: 10-95% RH non-condensing

Audible Alarm: ≥85dB (A) at 10 feet (3.05m), with voice messages "Fire!",

"Incendie!" and/or "Warning! Carbon Monoxide", "Attention! monoxyde de carbone!".

Storage/Transport Ambient Condition: -20~+50°C, 10-95% RH non-condensing

Low Battery Warning Silence: About 10 hours

Warning: As the battery in this unit is non-replaceable. Remove, discharge, dispose unit, and replace as soon as possible when unit in low battery warning.

Installation Location: Ceiling or wall

Detection Range: Max. 430 ft². (40 m²) within a room.

Size: About 6.1 x 1.6 in.

Weight: 11.2 +/- 0.35 Oz

Note: This combo smoke/CO alarm is specifically designed to detect carbon monoxide gas from any combustion source. It is not intended to detect any other type of gas.

5. Where to Install Smoke and Carbon Monoxide Alarms

The following suggestions are intended to help you with the placement and installation of your combo smoke/CO alarm.

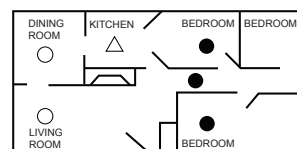

Single floor plan

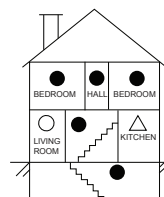

Multiple floor plan

- Smoke/CO alarms for required protection
- Smoke/CO alarms for additional protection
- △ Smoke alarms with silence control for additional protection

1. In all sleeping rooms and guest rooms.
2. Outside of each separate dwelling unit sleeping area, within 21 feet (6.4 m) of any door to a sleeping room, the distance measured along a path of travel.
3. On every level of a dwelling unit, including basements.
4. On every level of a residential board and care occupancy (small facility), including basements and excluding crawl spaces and unfinished attics.
5. In the living area(s) of a guest suite.
6. In the living area(s) of a residential board and care occupancy.
7. Smoke, heat, and combustion products rise to the ceiling and spread horizontally. Mounting the smoke alarm on the ceiling in the center of the room places it closest to all points in the room. Ceiling mounting is preferred in ordinary residential construction.
8. The device should be at least 6 feet (1.8 m) above the floor level.
9. When mounting a device on the ceiling, locate it at a minimum of 4 inch (10 cm) from the side wall.
10. When mounting the device on the wall, use an inside wall with top edge of the alarm at a minimum of 4 inch (10 cm) and maximum of 12 inch (30.5 cm) below the ceiling.
11. Put the device at both ends of a bedroom hallway or large room if the hallway or room is more than 30 feet (9.1 m) long.
12. Install the device on sloped, peaked or cathedral ceilings at or within 3 feet (0.9 m) of the highest point (measured horizontally).

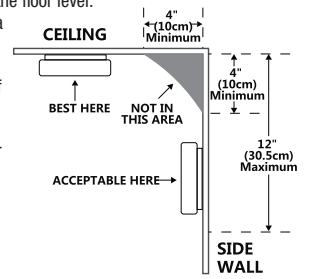

Mobile Home Installation

Modern mobile homes are built to be energy efficient. Follow the standard smoke alarm installation recommendations. However, in older mobile homes with less insulation, extreme heat or cold from the outside can transfer through poorly insulated walls and roofs. This may create a thermal barrier that prevents smoke from reaching a ceiling-mounted alarm. In such cases, install the smoke alarm on an interior wall with the top edge of the alarm no more than 12" (30.5 cm) below the ceiling. If you're unsure about the insulation quality of your mobile home or notice that the exterior walls and ceiling feel hotter or colder than the room air, place the alarm on an interior wall. NFPA 72 (National Fire Protection Association) requires smoke alarms to be installed in each sleeping area.

6. Installation Locations To Avoid

- To ensure the combo smoke/CO Alarm work properly and provide detection performance, do not install the device in the following places:
- Near appliances or areas where normal combustion regularly occurs (kitchens, near furnaces, hot water heaters). Install at least 10 feet(3m)way from these areas. Use specialized smoke alarm device with unwanted alarm control for these areas.
- In areas with high humidity, like bathrooms or areas near dishwashers or washing machines or directly above a sink. Install at least 10 feet (3m)away from these areas.
- Avoid spraying aerosols near the device.
- Next to a door or window, an extractor fan, air returns or heating and cooling supply vents. Install at least 3 feet(0.9m) away from these areas. The air could blow smoke away from the device, interrupting its alarm.
- In rooms where temperatures may fall below 0°C or rise above 40°C, or in humidity higher than 95%. These conditions will reduce battery life or cause a fault alarm.
- In extremely dusty, dirty, or insect - infested areas influence particles interfere with the device operation.
- In the garage. Products of combustion are present when you start your automobile.
- In an enclosed space (for example in a cupboard or behind a curtain).
- Where it can be obstructed (for example by furniture).
- Less than 4 inch (10 cm) from the peak of an "A" frame type ceiling.
- Near fluorescent lights. Electronic "noise" may cause nuisance alarms.
- Place out of the reach of children. Under no circumstance should children be allowed to handle the device.
- Normal cooking may cause nuisance alarms. If a kitchen alarm is desired, it should have an alarm silence feature and should not be installed within 6 feet(1.8m) of cooking appliances.

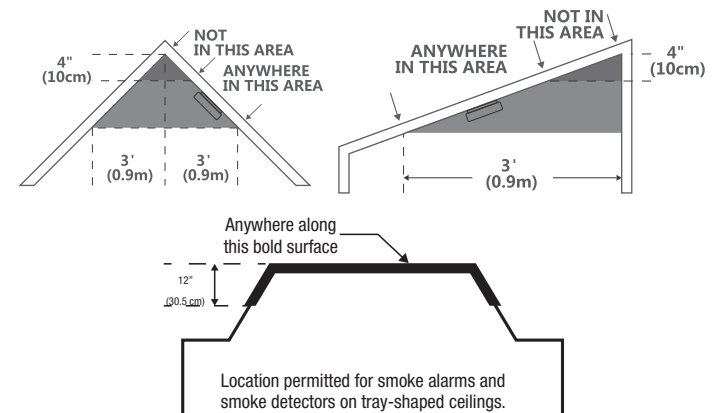

7. Installation Instructions

WARNING! This device should be located in an open and unobstructed area and shall not be located behind furniture, drapes, or any other object where it might not be seen or heard. The alarm shall be heard from all sleeping areas.

WARNING! Alarm users should add the phone numbers of their emergency service providers and qualified technicians on the two self-adhesive labels provided by the alarm manufacturer. Users should place one label next to the alarm and another near the source of fresh air they plan to gather. When the alarm indicates the presence of carbon monoxide, the user can escape as planned. If you install only one device in your home, install the device near bedrooms, not in the basement or furnace room.

Ceiling or Wall Mount

1. Hold the bracket against the wall in the desired location and use a pencil to mark the positions for the screw holes.
2. Drill holes at the marked points and insert the provided plastic anchors.
3. Align the bracket with the plugs and secure it by tightening the provided screws.
4. Mount the alarm onto the bracket.
5. Press the TEST/SILENCE button to test the device. Ensure the alarm sounds in the correct pattern.

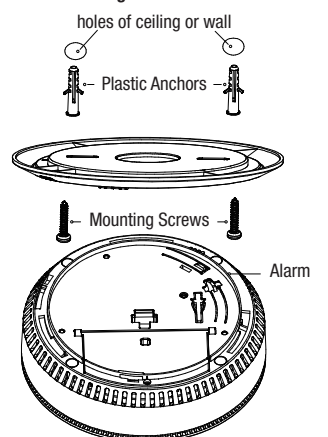

Important:

To install the alarm, rotate it clockwise.

To uninstall the alarm, rotate it counterclockwise.

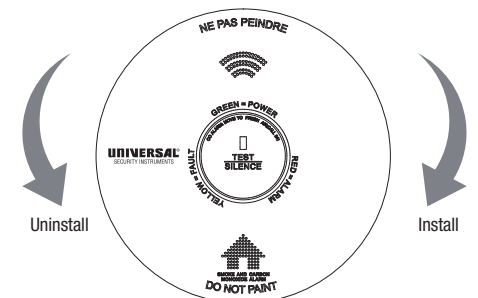

Optional locking feature

The locking feature is designed to discourage unauthorized removal of the Alarm. It is not necessary to activate the locks in single-family households where unauthorized battery or Alarm removal is not a concern.

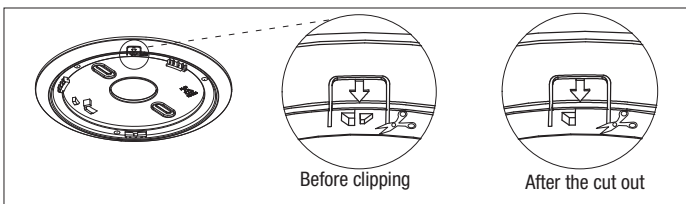

1. Remove the small triangular tab from the bracket to activate the locking feature.
2. Rotate the alarm clockwise to install it securely.

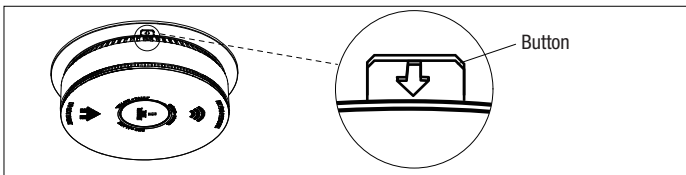

3. To remove the alarm unit, press the release button on the bracket while rotating the unit counterclockwise.

8. Battery Function

Battery activation and deactivation

How to activate battery:

After the unit is fully mounted into the mounting bracket, it will be automatically activated.

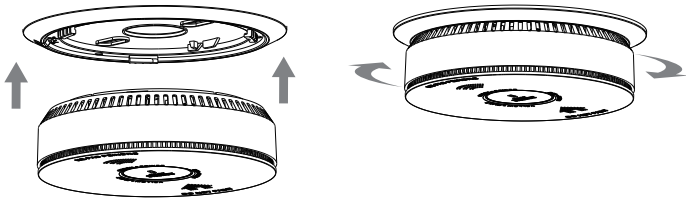

CAUTION: Test the alarm for correct operation using the facility when you activate the alarm.

How to deactivate battery:

1. Rip through the label cutout to access and remove the deactivation device key from the bottom case of the smoke alarm. (Diagram 1)
2. Using the key, insert it through the deactivation slot. (Diagram 2)
3. Check to see if the red indicator light on the smoke alarm stays lit, confirming that the alarm is deactivated.
4. Once the alarm is deactivated, it cannot be reactivated and must be replaced.

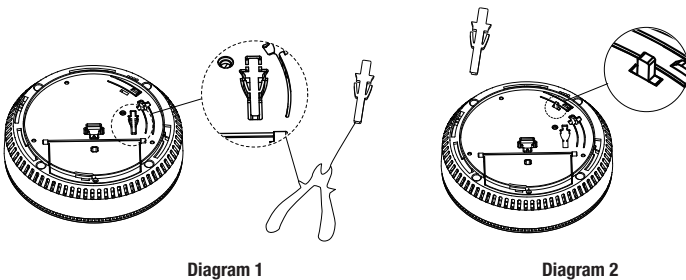

Diagram 1

Diagram 2

Important: Battery activation and deactivation feature is intended for one-time use only.

Battery/Device Disposal

WARNING! Fire, explosion, and severe burn hazard. Do not recharge, crush, disassemble, heat above 100°C, incinerate or expose contents to water.

1. Do not dispose of the device or the battery with regular household waste.
2. Dispose of the battery and device in accordance with all applicable federal, state, and local regulations.

9. Alarm Operation And Testing

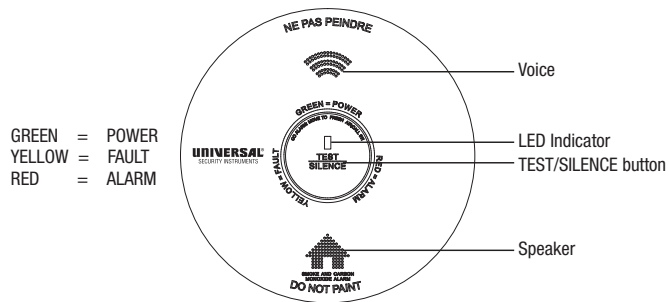

Voice Alerts

The device provides voice messages in addition to audible alarms to alert you of smoke detection carbon monoxide detection.

LED Indicators

POWER Indicator (Green): The green LED indicates the device's power status.

FAULT Indicator (Yellow)

The yellow LED signals malfunctions or low battery warnings.

ALARM Indicator (Red)

The red LED lights up to indicate an alarm status for smoke or carbon monoxide detection.

TEST/SILENCE Button

This button allows you to test the device or silence it during an alarm. Press and hold for more than 1 second to activate the test function or press briefly to activate the silence function.

Speaker

The speaker emits the smoke alarm, carbon monoxide alarm, and abnormal warning information.

Operation

The alarm becomes fully operational once it is powered on and the initial test is completed. When triggered, the alarm emits a loud alert accompanied by voice messages. Refer to sections 1 and 2 for details on alarm signals.

Testing

The TEST/SILENCE button is used to test the device and to silence the unit during a smoke alarm/carbon monoxide alarm. Press to keep it longer than 1 second to enable test function, or press to enable silence function.

Note: The alarm is loud. Stand at least 2.5 feet away from the unit or use ear protection when testing to prevent hearing damage.

Note: Never use an open flame to test the alarm. This could damage the unit or ignite nearby materials, leading to a fire hazard.

Chirping Alerts

If the unit begins to chirp due to low battery or End-of-Life mode, you can temporarily silence it by pressing the TEST/SILENCE button. See the Troubleshooting Guide for further instructions.

Note: Replace the unit immediately when it enters End-of-Life mode to ensure continued protection.

Low Battery Status: An intermittent "chirp" with a flashing yellow LED every 40 seconds indicates that the battery has reached a low voltage state. Since the battery is non-replaceable, you must replace the smoke alarm within 7 days to maintain uninterrupted protection. To prevent sleep disruption, you can temporarily silence the chirp by pressing the test button, which will mute the warning for 10 hours. After that, the chirp will resume, reminding you to replace the alarm.

10. Alarm Visual and Audible Indicators

Operate Mode	Visual (Flash)	Audible (Beep / Voice)	Description Mode
Power on	Preheat 60 seconds, with POWER indicator (Green LED) flashes every 2 seconds.	None	None
Standby	Green LED flashes every 40 seconds.	None	None
Test	RED LED flashes in time with alarm pattern.	Long press Test/Silence button; Three long beeps, Voice "Fire!", "Incendie!". Three long beeps; Pause for a second, four quick beeps, Voice "Warning, carbon monoxide", "Attention! monoxyde de carbone!", four quick beeps.	Press Test/Silence button once a week to verify proper alarm operation.
Smoke Alarm	RED LED flashes once a second.	Three long beeps with voice "Fire!", "Incendie!", three long beeps, 1.5 seconds pause, repeating.	None
CO Alarm	RED LED flashes in time with alarm pattern.	Four quick beeps with voice "Warning! Carbon Monoxide", "Attention! monoxyde de carbone!", four quick beeps, 5 seconds pause, repeating.	None
Smoke Alarm Silent Mode	RED LED flashes every 8 seconds.	Mute time for eight minutes	This feature is to be used only when a known alarm condition, such as smoke from cooking, activates the alarm.
High smoke levels cannot be silenced.	None	Voice "Too much smoke, cannot be silenced", "Trop de fumée, mode silencieux impossible".	None
CO Alarm Silent Mode	RED LED flashes every 8 seconds.	Mute time for 5 minutes.	This feature can help users confirm whether there is a CO leak.
Alarm memory mode	RED LED flashes every 40 seconds.	After button press, voice "Fire alarm before, The total number of historical alarms is X", "Alarme incendie avant, Le nombre total d'alarmes en mémoire est de X", "Carbon monoxide alarm before, XXX PPM", "détection de monoxyde de carbone avant, XXX PPM".	This feature will help the user determine which alarm went off. The visual indicator can maintain 72 hours. You can exit the visual indicator by pressing the button 3 times in succession. The voice will always exist.

11. Troubleshooting

Trouble Condition	Visual (flash)	Audible (Beep / Voice)	Description mode / Action
Low battery warning	Yellow LED flashes every 40 seconds.	Chirp every 40s. Voice "Low battery", "Pile faible".	Press Test/Silence button once to silence for 10h. Remove, discharge, dispose unit, and replace as soon as possible.
Smoke sensor fault warning	Yellow LED flashes every 40 seconds.	Chirp every 40s. Voice "Smoke sensor error", "Erreur du capteur de fumée".	Review Cleaning Your Alarm section. Remove, discharge, dispose unit, and replace as soon as possible.
CO Sensor Fault warning	Yellow LED flashes every 40 seconds.	After beep, Voice "CO sensor error", "Erreur du capteur de CO".	Review Alarm section. Press Test/Silence button once to attempt to reset unit. If error continues, remove, dispose unit, and replace as soon as possible.
End-of-Life	Yellow LED flashes twice every 40 seconds.	Double chirp every 40s. Voice "End of life", "Fin de vie".	Press Test/Silence button once to silence for 10 hours. Note: After 30 days of the first occurrence of end of life signal, can not be silenced anymore. Remove, discharge, dispose unit, and replace as soon as possible.

12. Carbon Monoxide (CO) Overview

Carbon monoxide (CO) is a colorless, odorless, and tasteless poison gas that can be fatal when inhaled. CO inhibits the blood's capacity to carry oxygen.

Possible Sources of CO

Inside your home, appliances used for heating and cooking are the most likely sources of CO. Vehicles and other combustion engines running in an attached garage and using a charcoal/gas grill or hibachi in an enclosed area are all possible sources of CO. Generators running in enclosed areas, such as garages or living spaces, will create CO. CO can be produced when burning any fossil fuel: gasoline diesel, propane, natural gas, oil and wood. It can be produced by any fuel-burning appliance that is malfunctioning, improperly installed, or not ventilated correctly, such as: Furnaces/boilers, gas ranges stoves, gas clothes dryers, water heaters, portable fuel burning space heaters, fireplaces, wood-burning stoves and certain swimming pool heaters. Blocked chimneys or flues, back drafting and changes in air pressure, corroded or disconnected vent pipes, or a loose or cracked furnace heat exchanger can also release CO into your building.

The following conditions can result in transient CO situations

1. Excessive spillage or reverse venting of fuel burning appliances caused by: i) Outdoor ambient conditions such as wind direction and/or velocity, including high gusts of wind; heavy air in the vent pipes (cold/humid air with extended periods between cycles), ii) Negative pressure differential resulting from the use of exhaust fans, iii) Simultaneous operation of several fuel burning appliances competing for limited internal air. iv) Vent pipe connection vibrating loose from clothes dryers, furnaces, or water heaters, v) Obstructions in or unconventional vent pipe designs which amplify the above situations.

2. Extended operation of unvented fuel burning devices (range, oven, fireplace, etc.).
3. Temperature inversions which can trap exhaust gasses near the ground.
4. Car idling in an open or closed attached garage, or near a home.

Symptoms of CO Poisoning

Initial carbon monoxide poisoning symptoms are similar to the flu with no fever and can include dizziness, severe headaches, nausea, vomiting and disorientation. Everyone is susceptible but experts agree that unborn babies, pregnant women, senior citizens and people with heart or respiratory problems are especially vulnerable. If symptoms of carbon monoxide poisoning are experienced seek medical attention immediately. CO poisoning can be determined by a carboxyhemoglobin test.

The following symptoms are related to CARBON MONOXIDE POISONING and should be discussed with ALL members of the household:

1. **MILD EXPOSURE:** Slight headache, nausea, vomiting, fatigue (often described as "Flu-like" symptoms).
2. **MEDIUM EXPOSURE:** Severe throbbing headache, drowsiness, confusion, fast heart rate.
3. **EXTREME EXPOSURE:** Unconsciousness, convulsions, cardio respiratory failure and death. The above levels of exposure relate to healthy adults. Levels differ for those at high risk. Many cases of reported carbon monoxide poisoning indicate that while victims are aware they are not feeling well, they become so disoriented they are unable to save themselves by either exiting the building, or calling for assistance. Also, young children and household pets may be the first affected.

WARNING! Exposure to high levels of carbon monoxide can be fatal or cause permanent damage and disabilities.

WARNING! The device may not prevent the chronic effects of carbon monoxide exposure, and that the device will not fully safeguard individuals at special risk.

13. Good Safety Habits: Develop An Escape Plan

Prepare and practice a home escape plan twice a year, including drills at night. Know two ways out of every room (door & window) and identify a meeting place outside the home where everyone will gather once they have exited the residence. When two people have reached the meeting place, one should leave to call the fire department's telephone number while the second person stay to account for additional family members. **Establish a rule that once you're out, you never reenter under any circumstance!**

- Make a floor plan indicating all doors and windows and least two escape routes from each room. Second story windows may need a rope or chain ladder.
- Have a family meeting and discuss your escape plan, showing everyone what to do in case of fire and where to meet after they leave the house.
- Ensure that small children hear the alarm and wake when it sounds. They must wake up on order to execute the escape plan. Practice allows all occupants to test your plan before an emergency. You may not be able to reach your children. It is important they know what to do.
- Familiarize everyone with the sound of the smoke/CO alarm and train them to leave you home when they hear it.
- Current studies have shown smoke/CO alarms may not awaken all sleeping individuals, and that it is the responsibility of individuals in the household that are capable of assisting other to provide assistance to those who may not be awakened by the alarm sound, or to those who may be incapable of safely evacuating the area unassisted.
- Install and maintain fire extinguishers on every level of the home and in the kitchen, basement and garage. Know how to use a fire extinguisher prior to an emergency.

14. How to Identify Nuisance Alarms

Smoke Nuisance

SILENCE: If you know why the alarm is sounding, and you can verify that it is not a life threatening situation, you can push the button silence the alarm for about 8 minutes. If the smoke is not too dense, that unit will silence. After the SILENCE period, the smoke alarm will automatically reset and sound the alarm if particles of combustion are still present. You can use SILENCE repeatedly until the air has been cleared of the condition causing the alarm.

NOTE: Dense smoke will override SILENCE and sound a continuous alarm. If no fire is present, check to see if one of the reasons listed in "Locations to avoid" may have caused the alarm. If a fire is discovered, get out and call the fire department or 911.

This alarm is designed to minimize nuisance alarms. Cigarette smoke will not normally cause the unit to alarm, unless the smoke is blown directly into the alarm. Combustion particles from cooking may set off the alarm if it is located too close to a cooking appliance. Large quantities of combustible particles are generated from spills or when broiling. Using the fan on a range hood which vents to the outside (non-recirculating type) will also help prevent nuisance alarms from occurring by removing these combustible products from the kitchen.

Carbon Monoxide (CO) Nuisance

RESET: Pushing the button during CO alarm allows the unit to reset calculations and double check for the presence of CO. If the unit re-alarms within 6 minutes, it is sensing high levels of CO which can quickly become a dangerous situation. Exit to fresh air and call 911.

WARNING! It is impossible to determine the source of a CO alarm using sight or smell. Always consider a CO alarm event as dangerous.

15. Maintenance Information

To ensure your alarm remains in good working condition, follow these simple steps:

1. Press the TEST/SILENCE button once a week to verify the sound and indicator operation.
2. Remove the alarm from the ceiling and use a soft brush attachment to clean the cover and vents monthly to eliminate dust and debris.
3. Do not use detergents or solvents, as these may damage the unit.
4. Avoid spraying air fresheners, hair spray, or other aerosols near the device to prevent interference.
5. Never paint the device, as this will seal vents and compromise sensor function. Avoid disassembling or cleaning the interior to maintain your warranty.
6. Reinstall the alarm immediately after cleaning to ensure continuous fire and CO protection.
7. Ventilate the area when using household cleaning products or chemicals nearby.

WARNING! - The following substances can affect the sensor and may cause false actions: methane, propane, isobutene, isopropanol, ethylene, benzene, toluene, ethyl acetate, hydrogen sulfide, sulfur dioxides, alcohol based products, paints, thinner, solvents, adhesives, hair sprays, after shaves, perfumes and some cleaning agents.

WARNING! - Your combo smoke/CO alarm will not be operational and will not monitor for smoke and CO levels without battery.

WARNING! - This apparatus is designed to protect individuals from the acute effects of carbon monoxide exposure. It may not however, prevent the chronic effects of carbon monoxide exposure and will not fully safeguard individuals at special risk or with specific medical conditions. If in doubt consult a medical practitioner.

16. Warranty Information

TEN-YEAR LIMITED WARRANTY

This product is warranted to be free from defects in material and workmanship for a period of 10 (ten) years from the date of purchase. For products containing a sealed battery, this warranty does not cover any damage that may be caused by the battery. Warranty does not apply to replaceable battery. This warranty applies only to the original consumer purchaser and only to products used in normal residential use and service. If this product is found to be defective, the only obligation, and your exclusive remedy, is the repair or replacement of the product, at the company's discretion, provided that the product has not been damaged through misuse, abuse, accident, modification, alteration, neglect, or mishandling. This Warranty shall not apply to any product which is found to have been improperly installed, set-up, or used in any way not in accordance with the instructions supplied with this product.

ALARM RETURNS

For replacement of this alarm under the terms of this Warranty, please contact customer service at feit.com/help for assistance. The company does not warrant, and specifically disclaims any warranty, whether express or implied, of fitness for a particular purpose, other than the warranty contained herein. No implied warranty on this product, created by state law, shall extend beyond the term of this warranty unless such law otherwise provides. The company specifically disclaims any liability and shall not be liable for any consequential or incidental loss or damage, including, but not limited to, damages to any equipment with which this product is used. Some states do not allow the exclusion or limitation of incidental or consequential damages, so the above limitations or exclusions may not apply to you. No agent, representative, dealer, or employee of the company has the authority to increase or alter the obligations or terms of this Warranty. This Warranty gives you specific legal rights and you may also have other rights which vary from state to state. This Warranty is only valid for merchandise purchased from outlets in the United States and Canada. This warranty expires upon product end-of-service life signal.