

LAYERED SLATE PYRAMID OUTDOOR WATER FOUNTAIN AND LED LIGHT GSI-798

Read the assembly instructions carefully and follow the care instructions. Save these instructions for future reference.

Select a smooth, level surface to place the fountain.

Assemble components on a soft, clean surface to avoid scratching or damaging the finish.



Inspect packaging to ensure all parts are accounted for before disposing of packing materials.



2-PERSON
 ASSEMBLY
 RECOMMENDED

No.	PARTS	QTY.
A	Pyramid Topper	1
B	Finger Light	1
C	Electric Submersible Pump	1
D	Basin	1
E	Pedestal Top	1
F	Pedestal Bottom	1
G	Decorative Stones	1 PK

NOTE: The water tubing is built into the pyramid topper. Take care when handling the water tube; detaching the water tube from the fountain topper will damage the fountain and void the product warranty.

Slate is a natural product; the colors and texture of each piece are unique so no two fountains will look the same. Variations in the slate colors and textures are not a cause for return.

Each fountain is cut from large slabs of slate. Spalling (flaking) may occur naturally over time, and/or if the slate is dropped. Use care when unpacking and assembling this fountain.

ASSEMBLY

1. Place Pedestal Top (E) onto Pedestal Bottom (F).
2. Gently set Basin (D) onto the pedestal.
3. Run Pump (C) power cord down the center of the basin, through the pedestal and under the groove in the back of the pedestal.
4. Connect Finger Light (B) to the short cable on the pump.
5. Insert the light into the underside of Pyramid Topper (A).
6. Connect Pump (C) to the water tube in Pyramid Topper (A) and gently place the topper onto the basin.
7. Rinse Decorative Stones (G) with clean water and gently place them inside the basin.
8. Fill the fountain with enough water to keep the pump fully submerged during operation; approximately 2 gallons.
9. Firmly connect the AC Adapter to the pump power cord and plug it into a properly grounded GFCI outlet.

Note: When first plugged in, there may be air in the pump. It may take several moments for trapped air to escape, allowing water to flow.

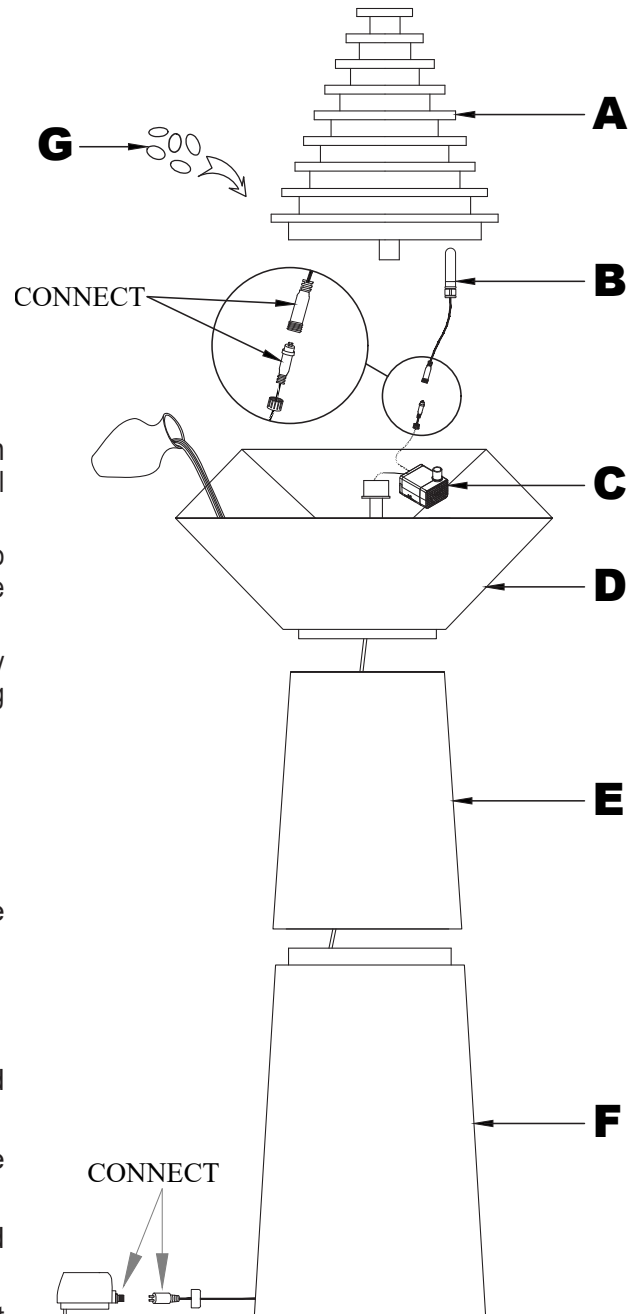

⚠ IMPORTANT INFORMATION ⚠

- For outdoor use only.
- Check the water level frequently to ensure the pump remains fully submerged; never allow the pump to run dry as it will burn out the motor.
- Only use water in this fountain. Distilled water will help prevent mineral buildup but is not required, avoid heavily chlorinated tap water as it may damage the fountain or pump.
- Periodically change the water to reduce scale and buildup — clean the fountain and pump regularly for optimal performance and appearance.
DO NOT use harmful additives such as bleach, chlorine, etc.
DO NOT use a pressure washer or abrasive materials to wash the fountain.
- Always shut off the power supply before cleaning and maintaining the fountain and the recirculating pump.
- Take care when handling the pump; only pick it up by the body of the pump, never by the power cord.
- During freezing temperatures, drain the fountain, disconnect the pump and store indoors; allowing ice to form may crack the fountain and will damage the pump.

Any modification to the product or failure to follow recommended care will void the product warranty.



TROUBLESHOOTING

- If water is not flowing within several moments of the fountain being plugged in, the pump may have trapped air, preventing water from circulating properly. Simply unplug the power supply for a few moments and plug it back in.
- If water is still not flowing, ensure that the pump is fully submerged and add water to the reservoir if necessary. Check the pump and tubing for obstructions. Ensure the water tube is not kinked.
- Some splashing is normal. Check the flow control on the body of the pump; it may need to be adjusted to achieve the desired flow rate.
- If water is not flowing evenly, it may be due to the porous nature of the slate material. Moisten the entire slate surface beneath the downspout to even out water flow.
- Pump noise may also be a result of the pump resting too close to the sides of the pyramid. Move the pump closer to the center of the basin to avoid noise from pump vibration.
- Pump noise may also be caused by air being trapped inside the pump. While the pump is submerged, gently tap the pump body with your finger to help release the trapped air.
- If the light is not working, ensure the adapter is fully connected and is plugged in.
- Check to make sure the power outlet is working; if in doubt about electrical connections, consult a certified electrician.

If you are still experiencing problems, please get in touch with our customer service team through one of the methods mentioned at the top of page 1. To expedite response time, please have the item number and order information available.

⚠ WARNING!

Manufacturer and seller expressly disclaim any and all liability from personal injury, property damage or loss, whether direct or indirect, or incidental, resulting from the incorrect attachment, improper use, inadequate maintenance, or neglect of this product.