

INSTRUCTION MANUAL



Altura Outdoor Adirondack Chair
SKU: OP6001

! NOTICE

Do not overtighten bolts. (Insert all bolts before tighten bolts.)

- Please do not exceed the weight limitations of this item.
- Do not stand on or use any part of this item as a step ladder.
- Firmly secure all bolts, screws and nuts before use.
- Reconfirm that all bolts, screws, and nuts are secure every 90 days.
- Do not use or store this item in the proximity of open flame or flammable/combustible chemicals.
- Be aware that some parts are heavy and have sharp edges.

TOOLS REQUIRED



ALLEN WRENCH
(PROVIDED)



WRENCH
(PROVIDED)



CHAIR
330 LBS
CAPACITY









1 PERSON
ASSEMBLY

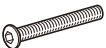
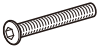

UP TO 30 MIN.
ASSEMBLY

HARDWARE

1 M6 x 80mm BOLT  2 PCS	2 M6 x 50mm BOLT  8 PCS	3 M6 x 40mm BOLT  4 PCS	4 M6 x 60mm BOLT  2 PCS	5 M6 NUT  8 PCS
6 M6 WASHER  8 PCS	7 WRENCH  1 PC	8 ALLEN WRENCH  1 PC		

PARTS

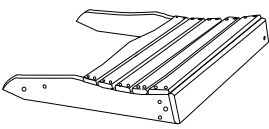
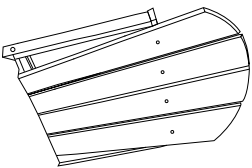
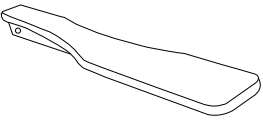
A CHAIR SEAT  1 PC	B CHAIR BACKREST  1 PC	C RIGHT CHAIR ARM  1 PC
---	---	---

PARTS

D

LEFT CHAIR ARM

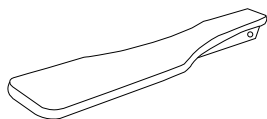

1 PC

E

RIGHT CHAIR LEG

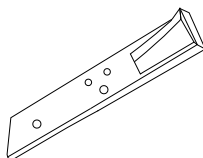

1 PC

F

LEFT CHAIR LEG

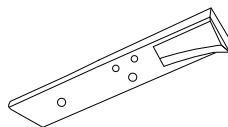

1 PC

G

BACK RAIL

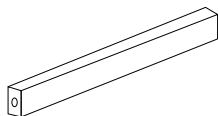

1 PC

H

FRONT RAIL

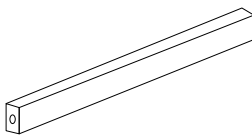

1 PC

PRODUCT ASSEMBLY - OVERALL VIEW

1

Look at following overall view of this chair and learn the exact position of each parts to be assembled.

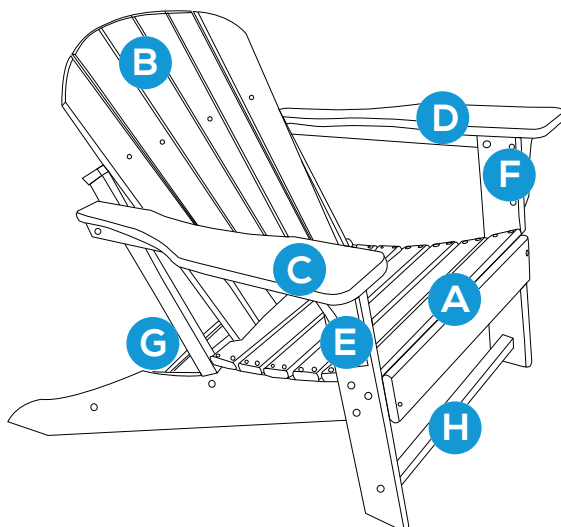

PRODUCT ASSEMBLY

1

Attach part F Left Chair Leg to part A Chair Seat with 3 pcs of part 2 bolt, part 6 washer and part 5 Nut. Do the same to part E Right Chair Leg and part A Chair Seat.

Attach part H Front Rail to two Chair legs with 2 pcs of part 3 Bolt.

Do not tighten bolts too much at this stage.

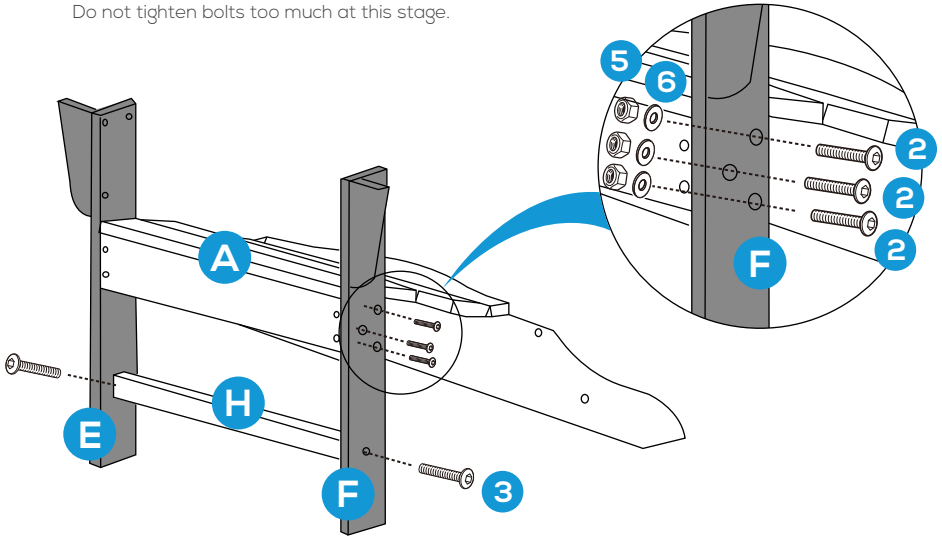

2

Attach part C Right Chair Arm to part E Right Chair Leg with 1pc of part 4 bolt, part 6 washer and part 5 Nut.

Do the same to attach part D Left Chair Arm to part F Left Chair Leg.

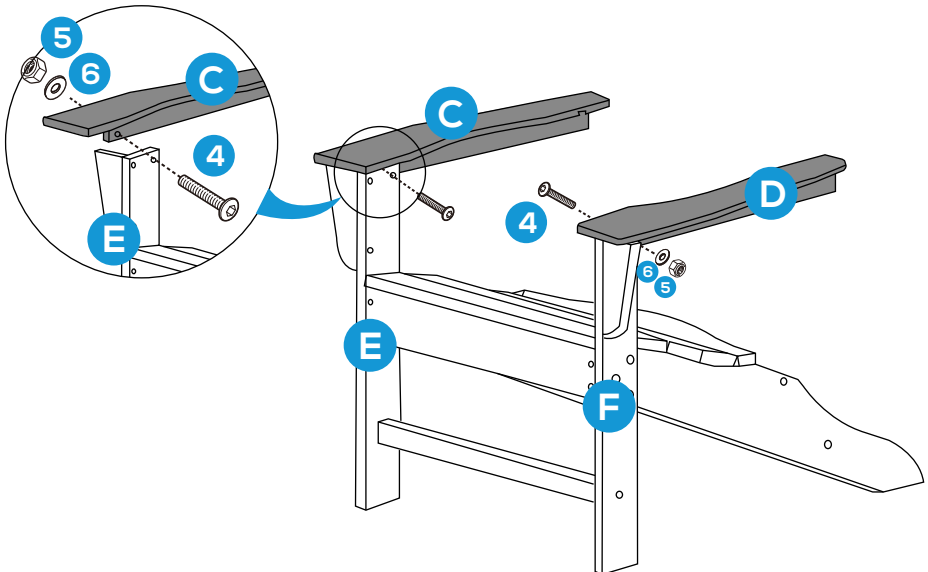

PRODUCT ASSEMBLY

3

Attach part B Chair Backrest to part C Right Chair Arm and part D Left Chair Arm with 2 pcs of part 1 Bolt.

Attach part B Chair Backrest to part A Chair Seat with 2 pcs of part 2 Bolt.

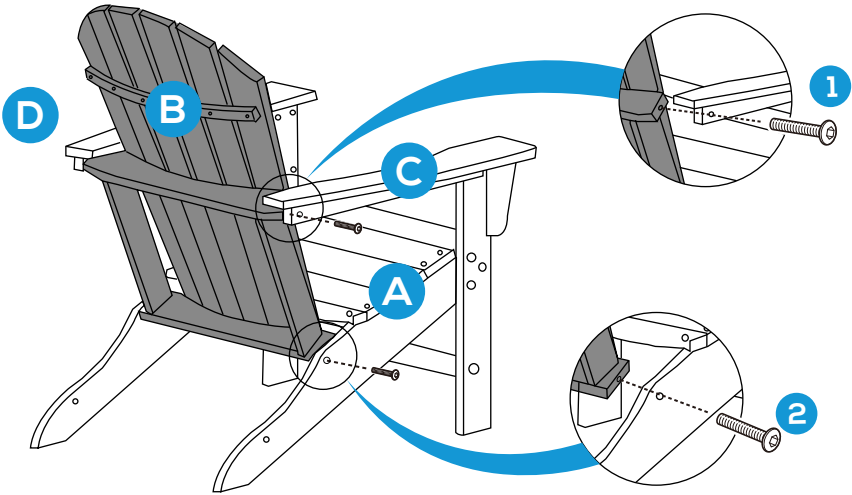

4

Attach part G Back Rail between rear legs of Part A Chair Seat with 2 pcs of part 3 bolt.

Check and tighten all the bolts and screws again and finish the assembly.

