

This drawing is the property of Rev-A-Shelf (RAS) and is disclosed in confidence to the extent its subject matter is original to RAS. Any vendor receiving this drawing from RAS shall hold and use this drawing for the sole benefit of RAS and shall not disclose it to, or use or reproduce it for any third party, or perform any act adverse to the interest of RAS with respect to this drawing without the express written permission of RAS. Vendors shall not revise any physical, dimensional or performance characteristic unless authorized by Rev-A-Shelf Engineering.

REV.	DATE	BY	DESCRIPTION OF CHANGE

AMERICAN PROJECTION		BY	DATE	REV-A-SHELF, INC.	
INCH [MM]		DRAWN	JOE	21.04.26	
TOLERANCES			MATERIAL	DRAWING NO.	SCALE
DEC.			FINISH	PART NO.	1:10
ANGLES				53PSP-15SC-FOG	SHEET OF
MATERIAL					1 2
FINISH					
DRAWING NO.					
PART NO.					
SCALE					
SHEET OF					

CUSTOMER DRAWING

REV-A-SHELF, INC.

SIZE B TWO-TIER 15" BLIND CORNER OPTIMIZER W/ SOFT CLOSE

DRAWING NO. SCALE 1:10

PART NO. SHEET OF 53PSP-15SC-FOG 1 2

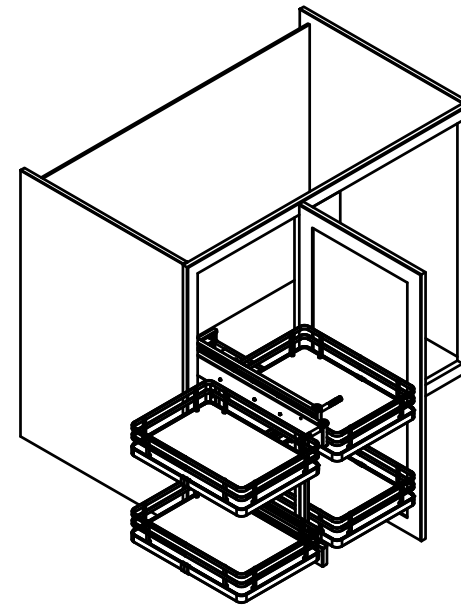
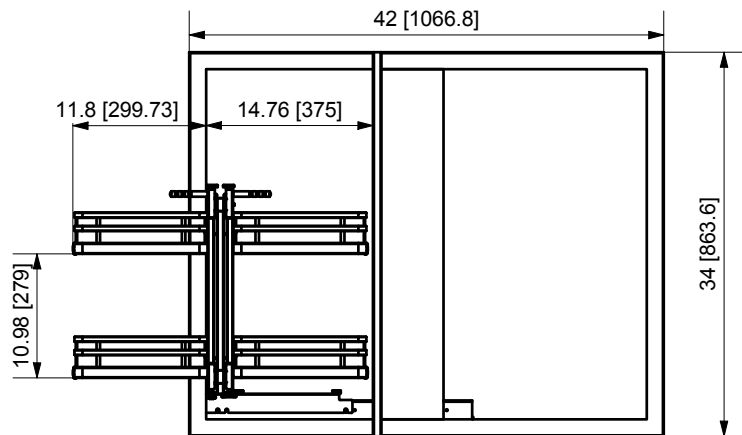
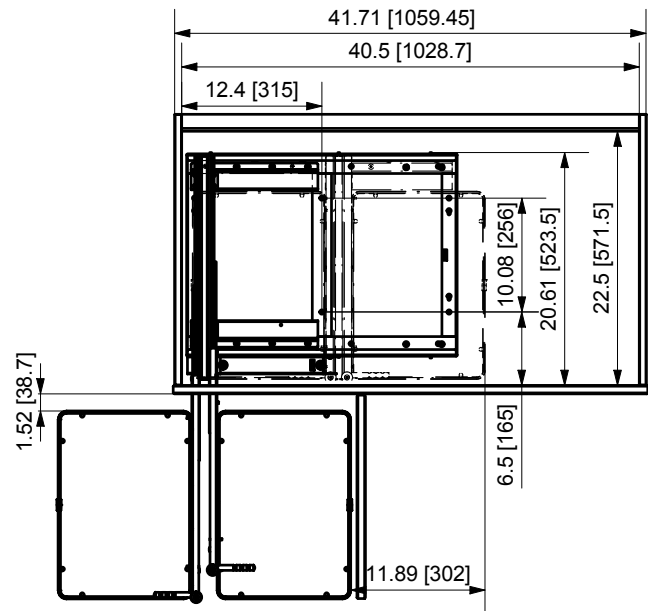

PART DIMENSIONS		
	MIN	MAX
WIDTH	26.4[670.5]	37.76[959]
DEPTH	20.4[518.2]	39.92[1014]
HEIGHT	21[533]	21[533]
WEIGHT		
DIAMETER		
RADIUS		
CONTAINER		
CAPACITY		
CONTAINER UOM		

MIN CABINET OPENING	
WIDTH	15.00[381]
DEPTH	21.66[550]
HEIGHT	22.00[559]

PRODUCT MAX WEIGHT RATING	

SLIDE SPECIFICATIONS				
SLIDE TYPE	BALL BEARING	SLIDE EXTENSION	19.69 [500]	MAX WEIGHT RATING
SLIDE CLOSING	SOFT CLOSE	SLIDE LENGTH	19.76 [502]	
SLIDE MOUNTING	FLOOR	SLIDE FINISH	ZINC	100LB

CUSTOMER DRAWING

This drawing is the property of Rev-A-Shelf (RAS) and is disclosed in confidence to the extent its subject matter is original to RAS. Any vendor receiving this drawing from RAS shall hold and use this drawing for the sole benefit of RAS and shall not disclose it to, or use or reproduce it for any third party, or perform any act adverse to the interest of RAS with respect to this drawing without the express written permission of RAS. Vendors shall not revise any physical, dimensional or performance characteristic unless authorized by Rev-A-Shelf Engineering.

REV.	DATE	BY	DESCRIPTION OF CHANGE

INCH [MM]	AMERICAN PROJECTION	BY	DATE	
		DRAWN	JOE 21.04.26	
MAT. (WOOD) .XX ±.03 [.8mm] (OTHER) .XX ±.02 [.5mm] (ALL) .XXX ±.005 [.13 mm] FRACTIONS ± 1/32 [.8 mm]		MATERIAL	DRAWING NO.	SCALE
TOLERANCES DEC. ANGLES ± 1/2°		FINISH	53PSP-15SC-FOG	1:17
SIZE TWO-TIER 15" BLIND CORNER OPTIMIZER W/ SOFT CLOSE			PART NO.	SHEET OF
DRAWING NO.			53PSP-15SC-FOG	2 2