

INSTRUCTION MANUAL

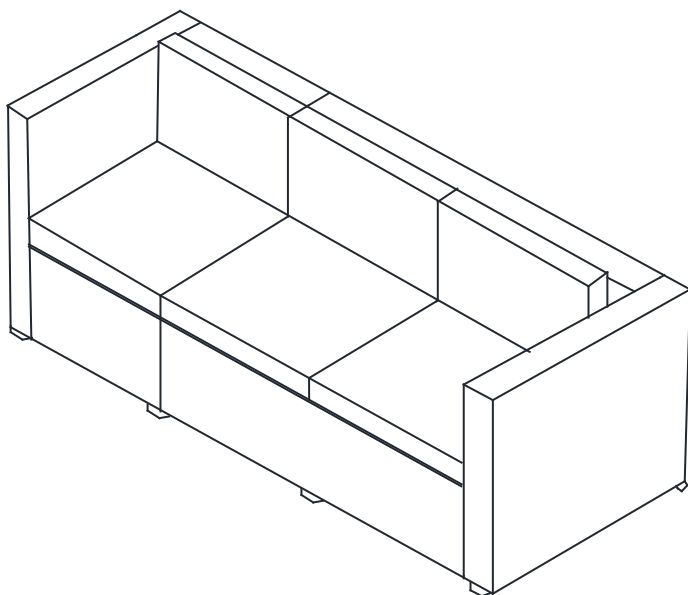

**82" Wide Outdoor Patio Sofa
with Cushions
SKU: P152-01-A**

V1.0

! NOTICE

Do not overtighten screws. (Insert all screws before tighten screws.)

- Please do not exceed the weight limitations of this item.
- Do not stand on or use any part of this item as a step ladder.
- Firmly secure all bolts, screws and nuts before use.
- Reconfirm that all bolts, screws, and nuts are secure every 90 days.
- Do not use or store this item in the proximity of open flame or flammable/combustible chemicals.
- Be aware that some parts are heavy and have sharp edges.

TOOLS REQUIRED



ALLEN WRENCH
(PROVIDED)



CORNER SOFA
660 LBS
CAPACITY



SINGLE SOFA
330 LBS
CAPACITY



1 PERSON
ASSEMBLY



UP TO 60 MIN.
ASSEMBLY

HARDWARE

1

M6 WASHER



30 PCS

2

M6 x 35mm
BOLT



21 PCS

3

M6 x 40mm
BOLT



9 PCS

4

ALLEN
WRENCH



1 PC

PARTS

A

CORNER LEFT SIDE

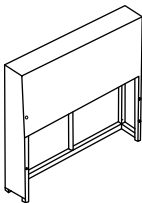

1 PC

B

BACKREST

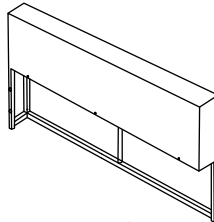

1 PC

C

FRONT PANEL

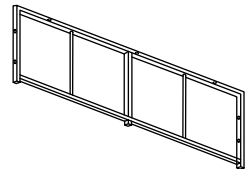

1 PC

PARTS

D

SIDE PANEL

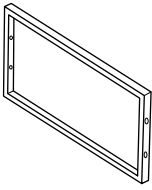

2 PCS

E

SOFA TOP

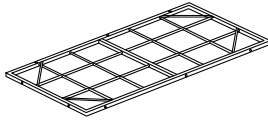

1 PC

F

CORNER RIGHT SIDE

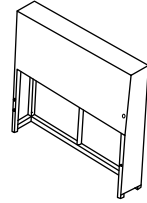

2 PCS

G

CORNER LEFT SIDE

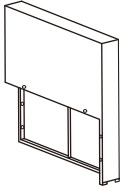

1 PC

H

CORNER F-PANEL

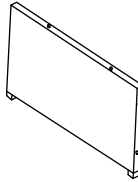

1 PC

I

SEAT TOP

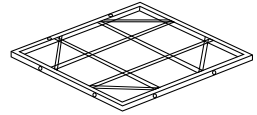

1 PC

CUSHIONS

Z1

SEAT CUSHION

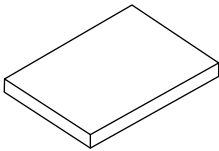

1 PC

Z2

BACK CUSHION

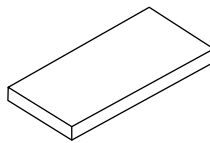

1 PC

PRODUCT ASSEMBLY - CORNER SEAT I

1

Attach part B Backrest to part A Corner Left Side with 2 PCS of hardware 1 Washer and hardware 2 Bolt.

Do not tighten screws too much at this stage.

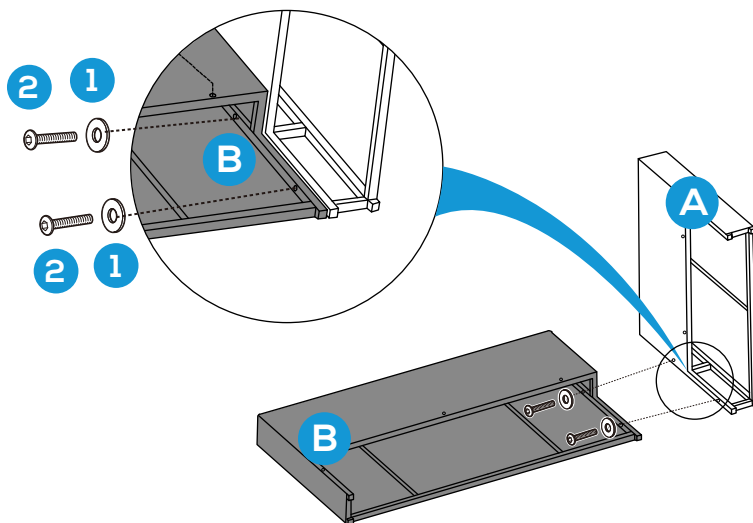

2

Attach part C Front Panel to part E Sofa Top with 3 PCS of hardware 1 Washer and hardware 2 Bolt.

Attach part D Side Panel to part C Front Panel with 2 PCS of hardware 1 Washer and hardware 2 Bolt.

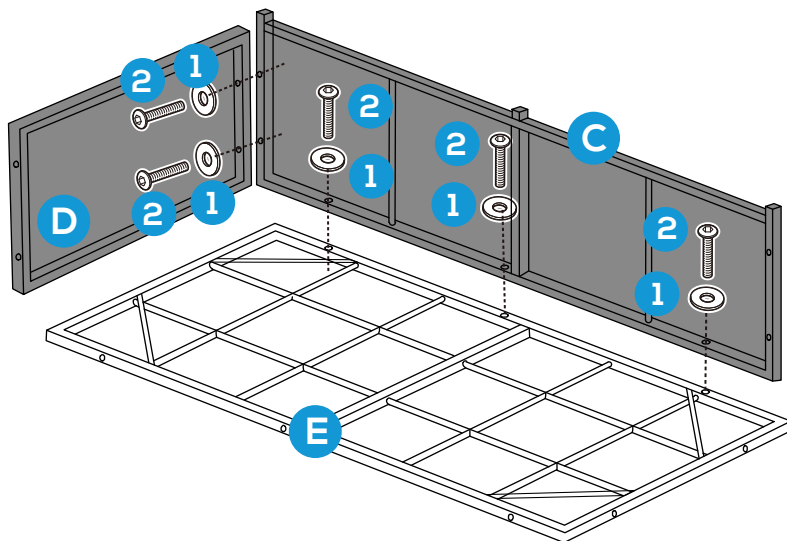

PRODUCT ASSEMBLY - CORNER SEAT I

3

Attach the assembled part (D+C+E) to assembled part (A+B) with 4 PCS of hardware 1 Washer and hardware 2 Bolt, 5 PCS of hardware 1 Washer and hardware 3 Bolt as below.

Tighten all the bolts again to ensure this corner seat is stable enough to use.

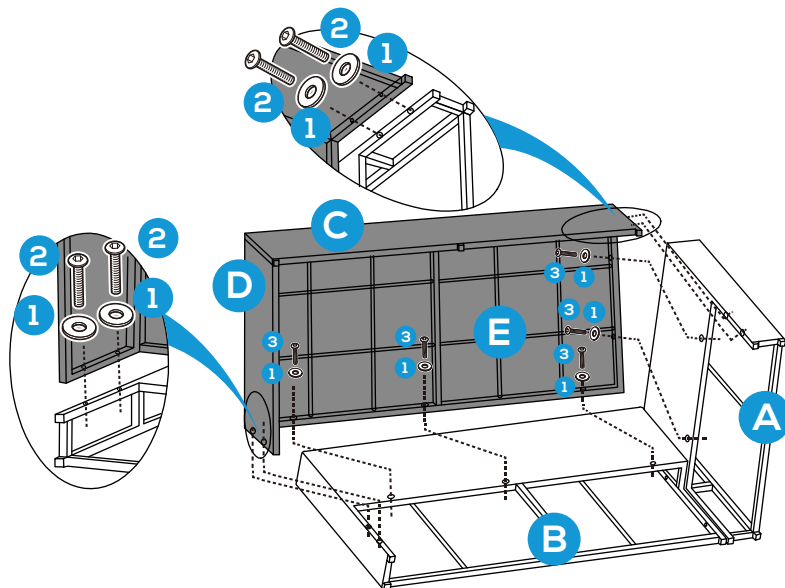

4

Place part Z1 Seat Cushion and part Z2 Back Cushions onto the Corner Seat.

The assembly of first corner seat finishes.

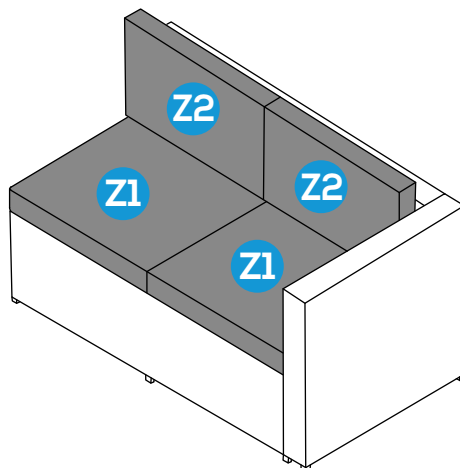

PRODUCT ASSEMBLY - CORNER SEAT II

5

Attach the part G Corner Left Side to part F Corner Right Side with 2 PCS of hardware 1 Washer and hardware 2 Bolt.

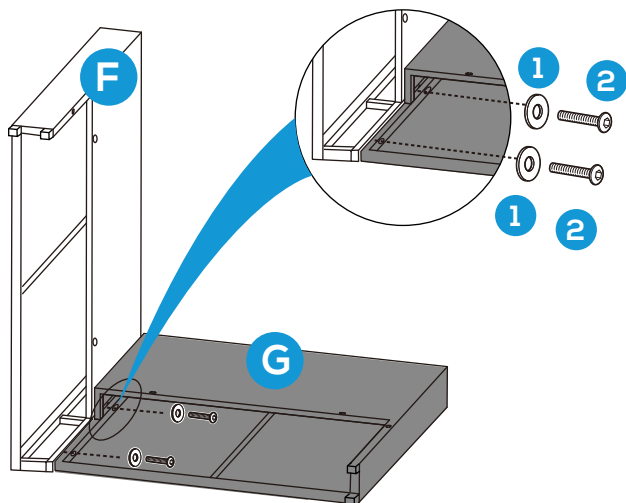

6

Attach part H Corner F-Panel to part I Seat Top with 2 PCS of hardware 1 Washer and hardware 2 Bolt.

Attach part D Side Panel to part H Corner F-Panel with 2 PCS of hardware 1 Washer and hardware 2 Bolt.

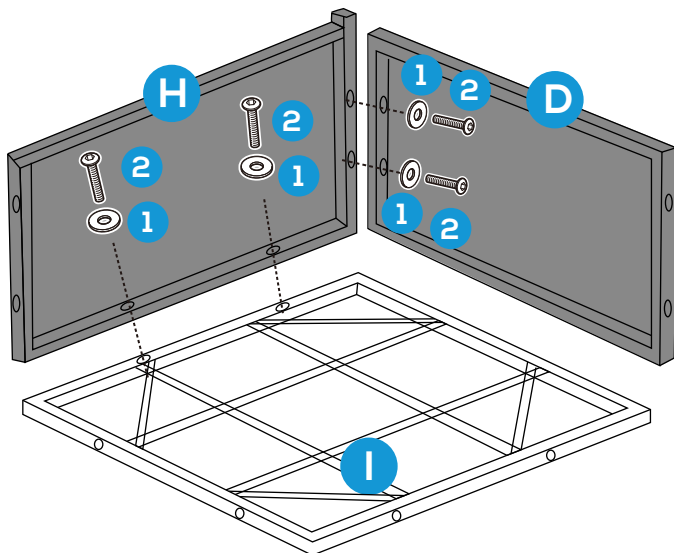

PRODUCT ASSEMBLY - CORNER SEAT II

7

Attach the assembled part (D+H+I) to assembled part (F+G) with 4 PCS of hardware 1 Washer and hardware 2 Bolt; 4 PCS of hardware 1 Washer and hardware 3 Bolt as below.

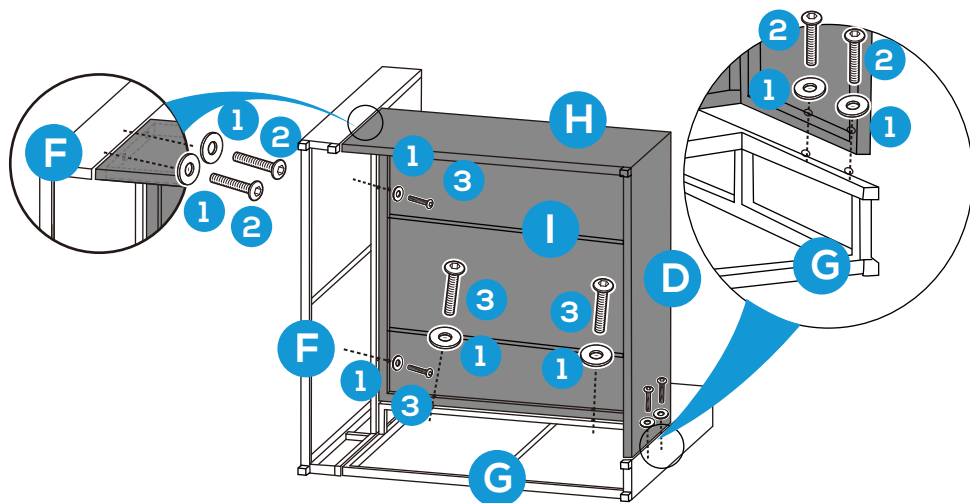

8

Place part Z1 Seat Cushion, part Z2 Back Cushions into the corner seat.

The assembly of single corner seat finishes.

