

CUSTOMER DRAWING

This drawing is the property of Rev-A-Shelf (RAS) and is disclosed in confidence to the extent its subject matter is original to RAS. Any vendor receiving this drawing from RAS shall hold and use this drawing for the sole benefit of RAS and shall not disclose it to, or use or reproduce it for any third party, or perform any act adverse to the interest of RAS with respect to this drawing without the express written permission of RAS. Vendors shall not revise any physical, dimensional or performance characteristic unless authorized by Rev-A-Shelf Engineering.

REV.	DATE	BY	DESCRIPTION OF CHANGE

INCH [MM]	AMERICAN PROJECTION	BY	DATE	REV-A-SHELF, INC.	
		DRAWN			
TOLERANCES		ANGLES 1/2±	MATERIAL	DRAWING NO.	SCALE
MAT.	DEC.		FINISH	PART NO.	SHEET 1 OF 2
(WOOD)	.XX .03 [.8mm]				
(OTHER)	.XX .02 [.5mm]				
(ALL)	.XXX .005 [.13mm]				
FRACTIONS	1/32 [.8mm]				

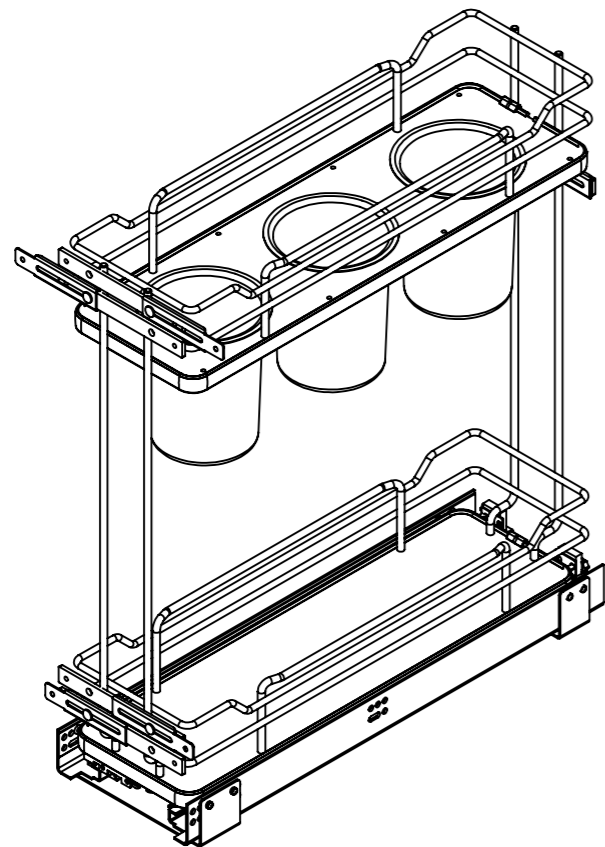

PART DIMENSIONS		
	MIN	MAX
WIDTH	7.21	9.95
DEPTH	21.64	
HEIGHT	23.98	

MIN CABINET OPENING	
WIDTH	7.21
DEPTH	21.70
HEIGHT	24

SLIDE SPECIFICATIONS				
SLIDE TYPE	DRAWER	SLIDE EXTENSION	20.24	MAX WEIGHT RATING
SLIDE CLOSING	SELF/SOFT	SLIDE LENGTH	21.54	
SLIDE MOUNTING	BOTTOM	SLIDE FINISH	ZINC	

CUSTOMER DRAWING

This drawing is the property of Rev-A-Shelf (RAS) and is disclosed in confidence to the extent its subject matter is original to RAS. Any vendor receiving this drawing from RAS shall hold and use this drawing for the sole benefit of RAS and shall not disclose it to, or use or reproduce it for any third party, or perform any act adverse to the interest of RAS with respect to this drawing without the express written permission of RAS. Vendors shall not revise any physical, dimensional or performance characteristic unless authorized by Rev-A-Shelf Engineering.

REV.	DATE	BY	DESCRIPTION OF CHANGE

INCH [MM]	AMERICAN PROJECTION 	DRAWN	BY	DATE	REV-A-SHELF, INC.
TOLERANCES MAT. DEC. (WOOD) .XX .03 [.8mm] (OTHER) .XX .02 [.5mm] (ALL) .XXX .005 [.13 mm] FRACTIONS 1/32 [.8 mm]		ANGLES 1/2±	MATERIAL	DRAWING NO.	SCALE
			FINISH	PART NO.	SHEET 1 OF 2