

SIDES	BOTTOM
4 KNOCKOUTS	1/2"KNOCKOUTS
2 1/2"KNOCKOUTS	
2 Pcs #8-32x1/2" screw install	
2 Pcs #10-32x1" screw install	
Material:Steel-0.0625"-G60 Galvanized	

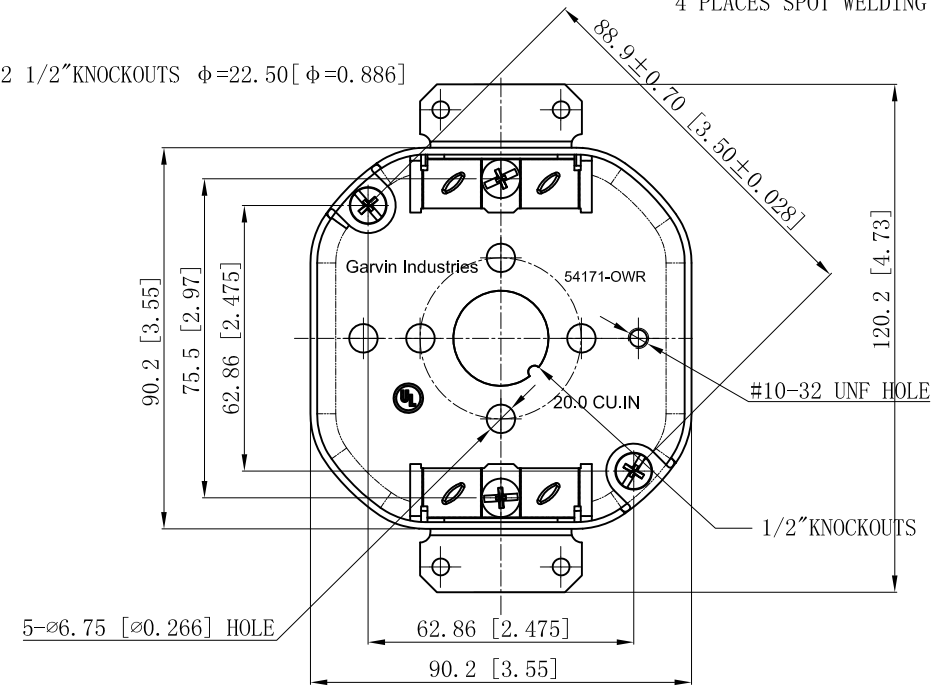
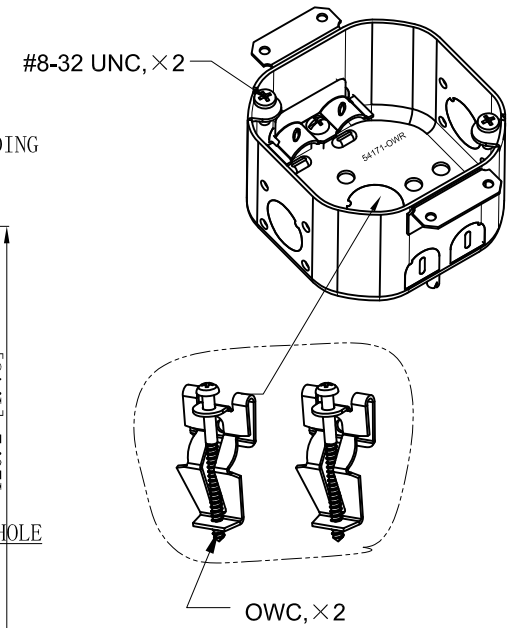
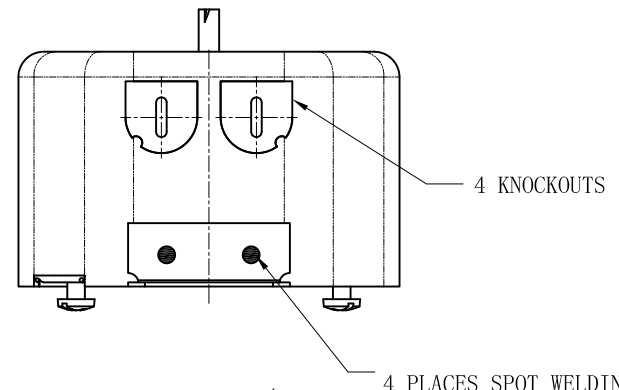
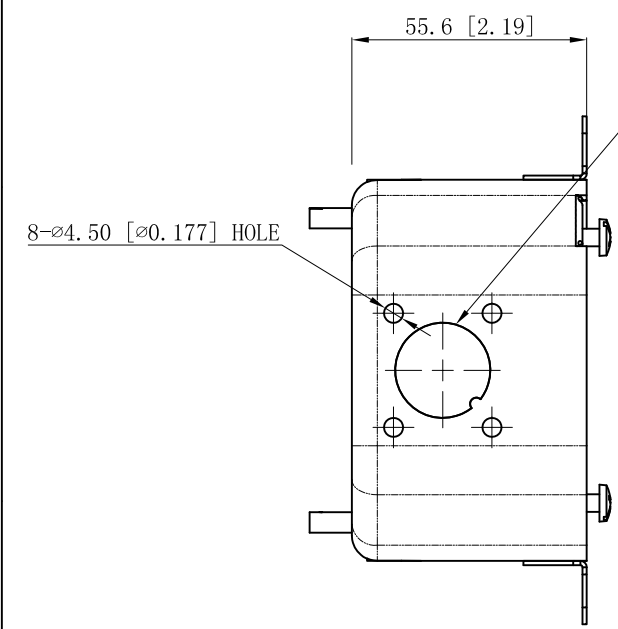

This data sheet is for reference only.GARVIN INDUSTRIES reserves the right to make changes to the design without prior notice.

DESCRIPTION
TRADE REFERENCE TERMS

STANDARD PACKING	TITLE		
	4"OCTBX, 2-1/8D, NM, OW		
	SIZE	DWG NO.	REV
	A4	54171-OWR	A
DATA SHEET			
www.garvinindustries.com			