

INSTRUCTION MANUAL

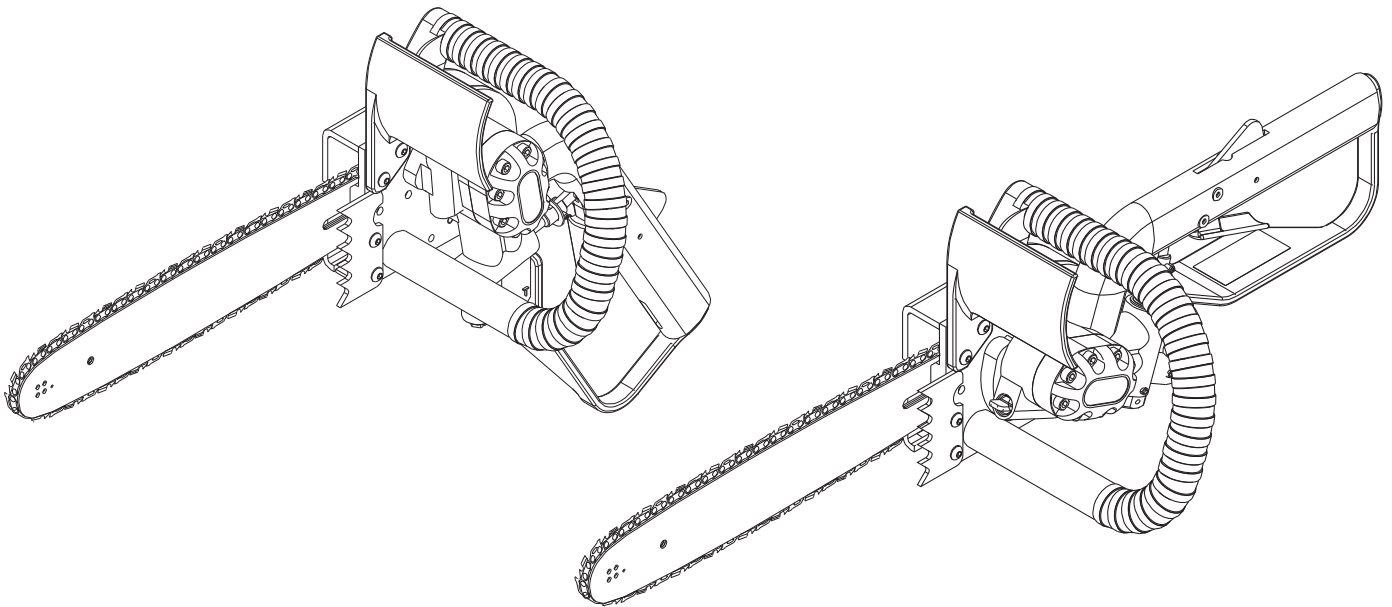

Chain Saws

HPS513 (49565)

HCS816 (49566)

HCS820 (49603)

Serial Codes FZH, FZJ, and GAM



Read and understand all of the instructions and safety information in this manual before operating or servicing this tool.

Register this product at www.greenlee.com

Table of Contents

Description	2
Safety	2
Purpose of this Manual	2
Other Publications	2
Important Safety Information	3–5
Identification	6
Specifications	7
Chain Saw Basics:	
Hazard Prevention	8–10
Compression and Tension	10
Cutting Techniques	11
Handle Adjustment	12
Setting the Super Spool™	13
Hoses and Fittings	13
Hose Connections	13
Typical Setup	13
Operation	14–15
Maintenance:	
Schedule	16
Checking and Setting the Automatic Chain Oiler	16
Saw Chain and Bar Maintenance	17–18
Sharpening the Saw Chain	19–20
Troubleshooting	21–22
Illustration and Parts List	23–25
Accessories	25

Description

Greenlee Utility Chain Saws are hydraulically powered cutting tools intended for pruning, limbing, and felling operations.

Powered by a rugged, direct-drive gear motor, this type of saw provides extraordinary cutting power for trimming and cutting from an aerial device or from the ground.

This saw can be customized in two ways. First, the control handle can be set to different positions — horizontal, 30° and 60° — for the benefit of the operator. Second, the blade and bar can be replaced with a blade and bar of a different length or pitch to adapt to various cutting situations. For blade-and-bar combinations that are compatible with this saw, refer to “Accessories” in this manual.

The Greenlee Greenlee Utility Super Spool™ allows these saws to be used on either Open-Center or Closed-Center hydraulic systems.

Super Spool™ is protected by U. S. Patent No. 4548229.

Safety

Safety is essential in the use and maintenance of Greenlee Utility tools and equipment. This instruction manual and any decals on the tool provide information for avoiding hazards and unsafe practices related to the use of this tool. Observe all of the safety information provided.

This manual introduces some general tree-trimming and felling guidelines. For more information on these procedures, contact:

National Arborist Association
 P.O. Box 1094
 Amherst, NH 03031-1094
 Phone: (603) 673-8952
 Fax: (603) 672-2613
 Website: www.natlarb.com

Purpose of this Manual

This instruction manual is intended to familiarize all personnel with the safe operation and maintenance procedures for the following products:

HPS513 (49565)	Serial Code FZH
HCS816 (49566)	Serial Code FZJ
HCS820 (49603)	Serial Code GAM

Keep this manual available to all personnel.

Replacement manuals are available upon request at no charge at www.greenlee.com.

Other Publications

Tool Owners/Users

SAE Standard J1273 (Hose and Hose Assemblies):
 Publication 99930323

Greenlee Utility Authorized Service Centers

Service Manual: Publication 99931850

All specifications are nominal and may change as design improvements occur. Greenlee Textron Inc. shall not be liable for damages resulting from misapplication or misuse of its products. Super Spool™ is a trademark of Greenlee Textron. Loctite® and 242® are registered trademarks of Loctite Corporation.

KEEP THIS MANUAL

IMPORTANT SAFETY INFORMATION

	<h3>SAFETY ALERT SYMBOL</h3>
<p>This symbol is used to call your attention to hazards or unsafe practices which could result in an injury or property damage. The signal word, defined below, indicates the severity of the hazard. The message after the signal word provides information for preventing or avoiding the hazard.</p>	
<h3>⚠ DANGER</h3>	
<p>Immediate hazards which, if not avoided, WILL result in severe injury or death.</p>	
<h3>⚠ WARNING</h3>	
<p>Hazards which, if not avoided, COULD result in severe injury or death.</p>	
<h3>⚠ CAUTION</h3>	
<p>Hazards or unsafe practices which, if not avoided, MAY result in injury or property damage.</p>	

	<h3>⚠ WARNING</h3>
<p>Skin injection hazard: Oil under pressure easily punctures skin causing serious injury, gangrene or death. If you are injured by escaping oil, seek medical attention immediately.</p> <ul style="list-style-type: none"> • Do not use fingers or hands to check for leaks. • Do not hold hose or couplers while the hydraulic system is pressurized. • Depressurize the hydraulic system before servicing. 	

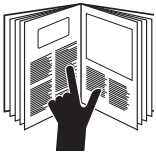
	<h3>⚠ WARNING</h3>
<p>Read and understand all of the instructions and safety information in this manual before operating or servicing this tool.</p> <p>Failure to observe this warning could result in severe injury or death.</p>	

	<h3>⚠ WARNING</h3>
<p>Electric shock hazard: This tool is not insulated. When using this unit near energized electrical lines, use only certified non-conductive hoses and proper personal protective equipment.</p> <p>Failure to observe this warning could result in severe injury or death.</p>	

	<h3>⚠ WARNING</h3>
<p>Before operating the saw, read and understand the following explanations in this manual:</p> <ul style="list-style-type: none"> • Pull-In Pull-in can occur when the blade at the bottom of the bar contacts a foreign object, such as a nail, or when the blade is pinched in the cut. The saw will be suddenly and forcefully pulled away from the operator. • Push-back Push-back can occur when the blade at the top of the bar contacts a foreign object, such as a nail, or when the blade is pinched in the cut. The saw will be suddenly and forcefully pushed back toward the operator. • Kickback Kickback can occur when the chain at the guide bar tip contacts anything. The bar of the saw will travel upward and back, toward the operator. <p>Failure to observe this warning could result in severe injury or death.</p>	

IMPORTANT SAFETY INFORMATION

	<p style="text-align: center;">⚠ WARNING</p> <p>Wear a hard hat when using this tool. Failure to observe this warning could result in severe injury or death.</p>
---	--

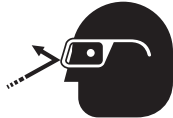
	<p style="text-align: center;">⚠ WARNING</p> <p>Wear eye protection when operating or servicing this tool. Failure to wear eye protection could result in serious eye injury from flying debris or hydraulic oil.</p>
---	--

	<p style="text-align: center;">⚠ WARNING</p> <p>Wear hearing protection when using this tool. Long-term exposure to high noise levels could result in hearing loss.</p>
---	--

	<p style="text-align: center;">⚠ WARNING</p> <p>Wear foot protection when using this tool. Failure to observe this warning could result in serious injury.</p>
---	---

	<p style="text-align: center;">⚠ WARNING</p> <p>Some types of timber can produce hazardous dust when cut. Wear a dust mask to prevent breathing hazardous dust. Failure to observe this warning could result in temporary breathing difficulty or serious injury.</p>
---	--

<p style="font-size: 1.2em;">⚠ WARNING</p>
<ul style="list-style-type: none"> • Do not change accessories, inspect, adjust or clean tool when it is connected to a power source. Accidental start-up can result in serious injury. • Keep the handles clean, dry and free of hydraulic fluid. • Maintain a firm grip on tool, using both hands with thumbs and fingers encircling the handles at all times. Serious injury can result if an operator does not control the tool. • Do not lock the trigger in the Power-ON position. Operator cannot stop tool when trigger is locked. • Do not remove or modify the trigger actuator. Accidental start-up can result in serious injury. • Wear protective gloves when handling or adjusting the chain. The chain can cut even when stationary. <p>Failure to observe these warnings could result in severe injury or death.</p>

	<p style="text-align: center;">⚠ WARNING</p> <p>Saw body, bar, blade and other components will be hot during and after use. Use care when handling the saw. Hot surfaces can cause serious burns. Failure to observe this warning could result in severe injury or death.</p>
---	--

<p style="font-size: 1.2em;">⚠ WARNING</p>
<p>To transport the chain saw:</p> <ul style="list-style-type: none"> • Allow the chain to stop rotating. • Wait for the chain to cool. • Use an appropriate guide bar sheath or scabbard. • Carry the saw with the guide bar toward the rear. <p>Failure to observe these warnings could result in severe injury or death.</p>

IMPORTANT SAFETY INFORMATION

⚠ WARNING

Do not disconnect tool, hoses or fittings while the power source is running or if the hydraulic fluid is hot. Hot hydraulic fluid could cause serious burns.

⚠ WARNING

Do not reverse hydraulic flow. Operation with hydraulic flow reversed could cause tool malfunction. Connect the pressure hose and tank hose to the proper ports.

⚠ CAUTION

- Use this tool for cutting wood only. Any other use can result in injury or property damage.
 - Inspect tool before use. Replace any worn, damaged or missing parts. A damaged or improperly assembled tool can malfunction, injuring nearby personnel.
 - Inspect hydraulic hoses and couplings every operating day. Repair or replace if leakage, cracking, wear or damage is evident. Damaged hoses or couplings can fail resulting in injury or property damage.
 - Excuse all bystanders and unnecessary personnel from the work area when operating the tool. Nearby personnel can be injured by falling debris.
- Failure to observe these precautions can result in injury.

⚠ CAUTION

Hydraulic oil can cause skin irritation.

- Handle the tool and hoses with care to prevent skin contact with hydraulic oil.
- In case of accidental skin contact with hydraulic oil, wash the affected area immediately to remove the oil.

Failure to observe these precautions can result in injury.

⚠ CAUTION

Vibration hazard:

Apply just enough pressure to do the work. Applying excess pressure to the tool can cause operator discomfort or temporary numbness.

Failure to observe this precaution can result in injury.

IMPORTANT

- Check the operation of the automatic oiler frequently. Refer to “Checking and Setting the Automatic Chain Oiler” in this manual.
- Check the chain frequently for proper tension and sharpness. Tension and sharpen as necessary. Refer to the instructions under “Saw Chain and Bar Maintenance.”
- Check the fluid level of the power source reservoir frequently. The automatic oiler uses hydraulic fluid to lubricate the bar and chain, and will cause the fluid level to drop.

IMPORTANT

Procedure for disconnecting hydraulic hoses, fittings or components:

1. Move the flow lever on the hydraulic power source to the OFF position.
2. Stop the power source.
3. Follow the sequence under Disconnecting Hoses to prevent pressure buildup. In case some pressure has built up, loosen hoses, fittings or components slowly.

IMPORTANT

Emergency stop procedure:

1. Release the trigger.
2. Shut off the hydraulic power source.

Note: Keep decals clean and legible. Replace decals when necessary.

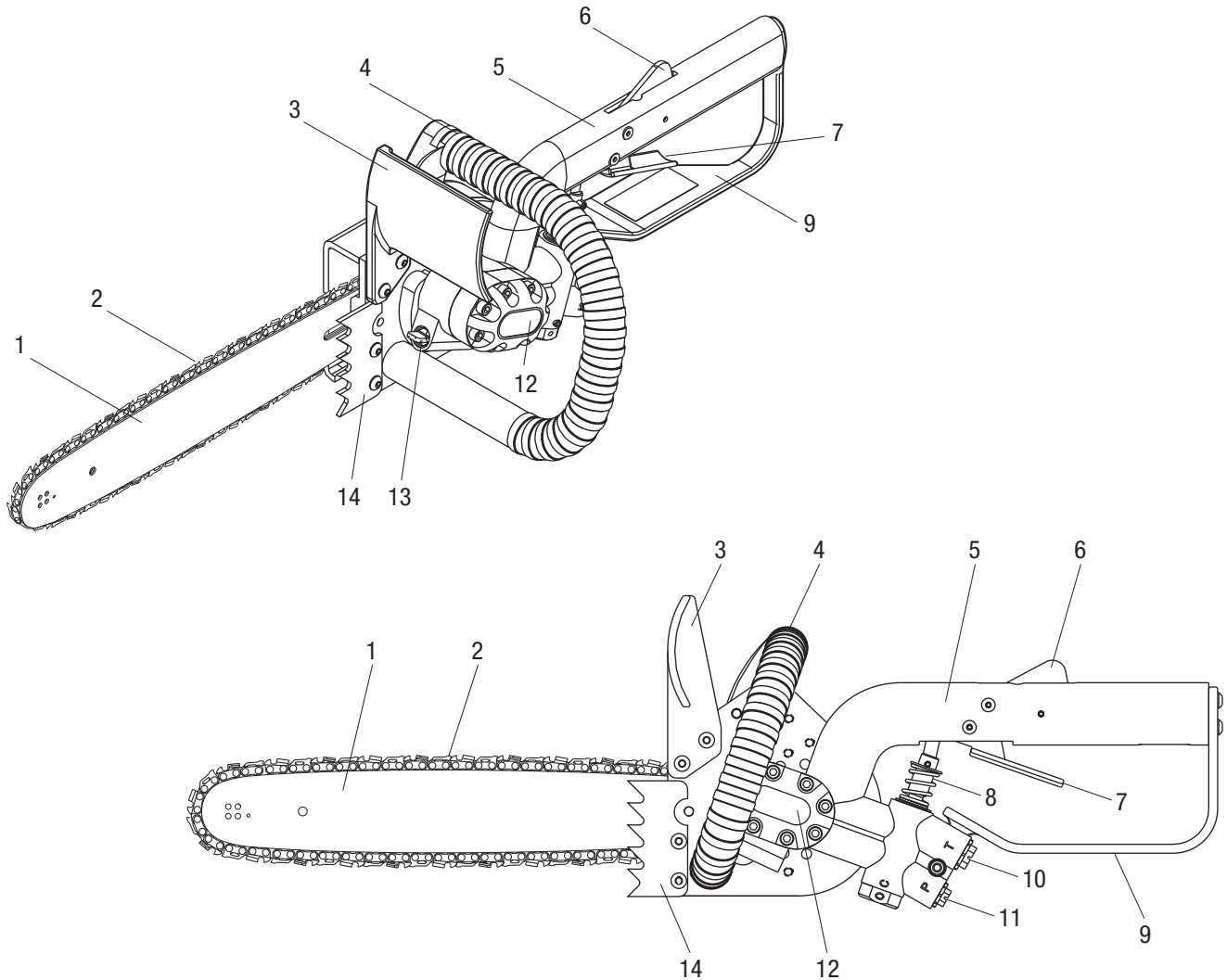
Identification

Parts of the Chain Saws

- | | |
|---------------------|--|
| 1. Bar | 8. Trigger Spool |
| 2. Chain | 9. Lower Handle |
| 3. Shroud | 10. Tank Port |
| 4. Front Handle | 11. Pressure Port |
| 5. Control Handle | 12. Hydraulic Motor with Serial Number |
| 6. Trigger Actuator | 13. Automatic Oiler Adjustment Screw |
| 7. Trigger | 14. Spike Rack |

Specifications

Application Information

Refer to “Accessories” in this manual.

Chain Saw

Type of Hydraulic System.....Open-Center or Closed-Center

Hydraulic Ports

Pressure 9/16–18 SAE O-ring

Tank..... 3/4–16 SAE O-ring

Chain Speed

@ 15.1 l/min (4 gpm)552 m/min (1814 fpm)

@ 30.3 l/min (8 gpm) 1075 m/min (3527 fpm)

Mass/Weight

HPS513 3.9 kg (8.5 lb)

HCS816..... 4.3 kg (9.5 lb)

HCS820..... 4.6 kg (10.2 lb)

Length

HPS513652 mm (25.68")

HCS816 and HCS820806 mm (31.75")

Width254 mm (10")

Height.....224 mm (8.5")

Type of Hydraulic System.....Open-Center or Closed-Center

Flow

Minimum 15.1 l/min (4 gpm)

Recommended..... 22.7 l/min (6 gpm)

Maximum 30.3 l/min (8 gpm)

Filtration.....10 Micron (nominal)

Pressure Relief Setting 138 bar (2000 psi)

Back Pressure (Maximum*) 13.8 bar (200 psi)

* 13.8 bar (200 psi) is the maximum agreed standard back pressure for the HTMA (Hydraulic Tool Manufacturers Association). Greenlee Utility tool will operate satisfactorily at this standard.

1. Maximum hydraulic fluid temperature must not exceed 60 °C (140 °F). A sufficient oil cooling capacity is needed to limit the hydraulic fluid temperature.
2. Hydraulic flow must not exceed 30.3 l/min (8 gpm). Install a flow meter in the return line to measure the rate of hydraulic flow before using the tool.
3. Pressure relief valve setting must not exceed 138 bar (2000 psi) at your tool’s maximum flow. Locate the pressure relief valve in the supply circuit to limit excessive hydraulic pressure to the tool.

Hydraulic Power Source

⚠ WARNING

Do not exceed the following hydraulic power source maximums:

- Hydraulic flow: 30.3 l/min (8 gpm)
- Pressure relief: 138 bar (2000 psi)
- Back pressure: 13.8 bar (200 psi)

Failure to observe this warning could result in severe injury or death.

Hydraulic Schematic

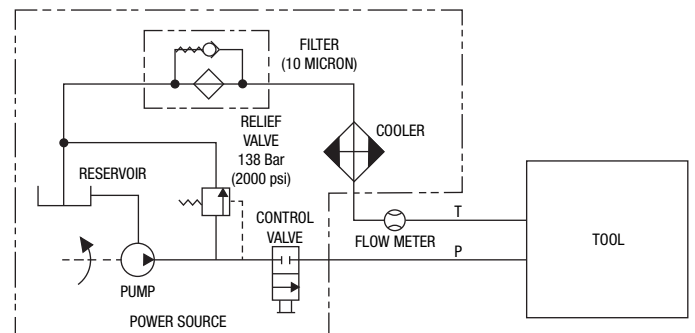

Recommended Hydraulic Fluids

Use any non-detergent, petroleum-based hydraulic fluid which meets the following specifications or HTMA specifications.

S.U.S. @:

38 °C (100 °F)..... 140 to 225

99 °C (210 °F)..... 40 minimum

Flash Point..... 170 °C (340 °F) minimum

Pour Point..... -34 °C (-30 °F) minimum

Chain Saw Basics

This section introduces some basic principles of chain saw use (Hazard Prevention, Compression and Tension, and Cutting Techniques). For more information on proper tree-trimming and felling procedures, contact the National Arborist Association at the address shown under "Safety" at the front of this manual.

HAZARD PREVENTION

The cutting action of this chain saw is performed by a chain-type blade driven at high speed by a powerful hydraulic motor. When used carefully and properly, the chain saw is a highly effective cutting tool.

When used improperly, or when anything interferes with the normal rotation of the blade, the operator could very suddenly and very quickly lose control of the saw. Such loss of control can result in harm to the operator. The three terms that describe loss of control are pull-in, push-back, and kickback.

Pull-In

Pull-in can occur when the blade at the bottom of the bar is doing the cutting. If the blade is suddenly pinched in the cut, or if it contacts a foreign object such as a nail, the saw may be suddenly and forcefully pulled away from the operator.

Figure 1 – Pull-In

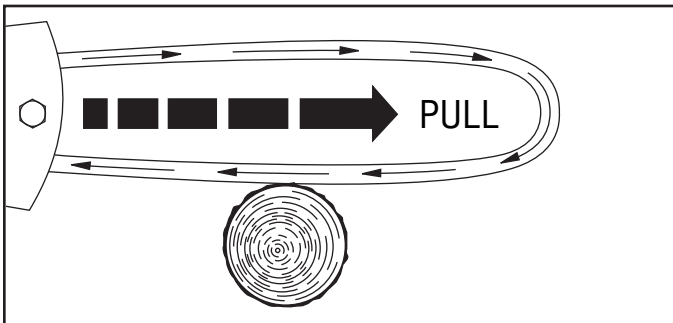

Push-Back

Push-back can occur when the blade at the top of the bar is doing the cutting. If the blade is suddenly pinched in the cut, or if it contacts a foreign object such as a nail, the saw will be suddenly and forcefully pushed back toward the operator.

Figure 2 – Push-Back

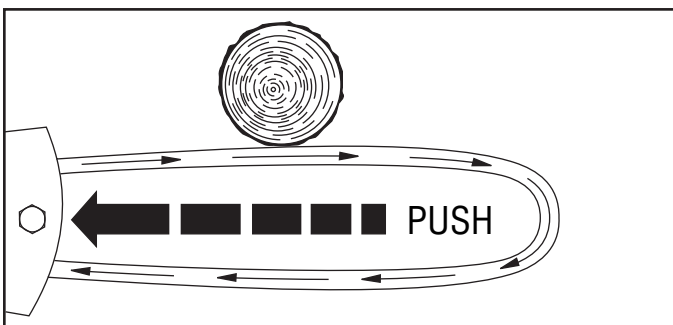

Kickback

Kickback is much more hazardous than pull-in or push-back. When kickback happens, the entire saw may rotate suddenly and forcefully. The bar of the saw may quickly travel upward and back, toward the operator.

Kickback can occur when the blade at the guide bar tip contacts anything while the chain is rotating. Some causes for kickback are:

- using the guide bar tip for cutting.
- contacting a nail or other metal object when cutting.
- accidental contact when cutting more than one branch at a time.

Figure 3 – Using Guide Bar Tip for Cutting

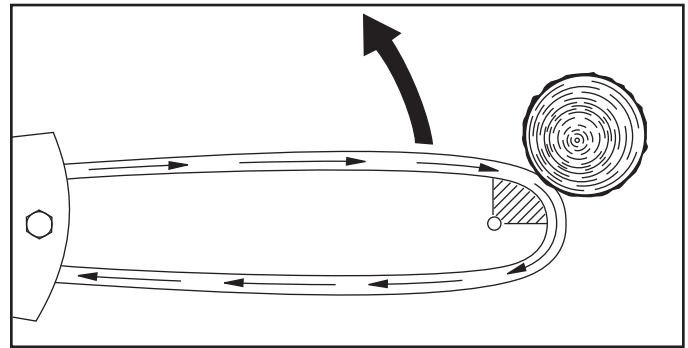

Figure 4 – Contact with Metal Objects

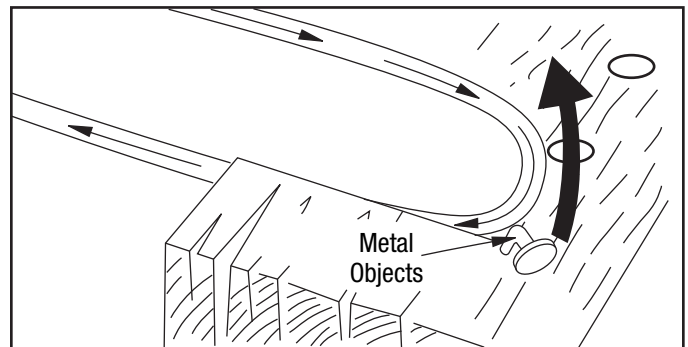
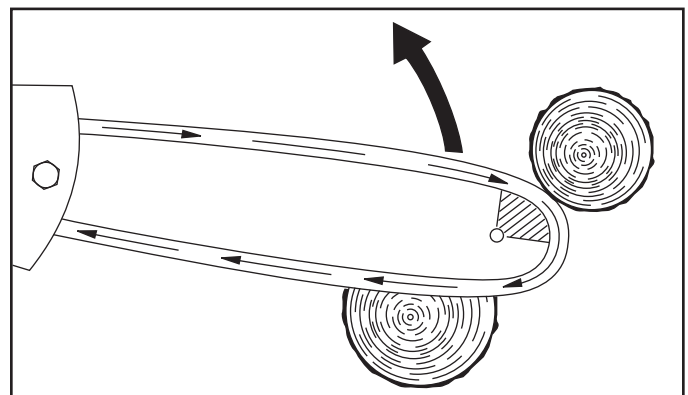

Figure 5 – Cutting More Than One Branch at a Time



Chain Saw Basics (cont'd)

Preventing Pull-In, Push-Back and Kickback

The chain/bar combination and shroud are intended to prevent or reduce the likelihood and severity of kickback. Verify that these items are in good working order (chain is sharp and properly tensioned, shroud is not damaged, etc.) to get the maximum benefit from these features. If worn or damaged, replace these items with Greenlee Utility replacement parts.

General Tips:

- Maintain the saw properly. Verify that the blade is sharp and has been properly tensioned.
- Do not allow the guide bar tip to contact anything.
- Do not over-reach.
- Do not use the saw above shoulder height.
- Cut only one limb, branch, or log at a time.
- Be aware that small-diameter limbs or branches are more likely to catch the blade, causing pull-in or kickback.

Cutting Procedure:

- Hold the chain saw securely with both hands and maintain a firm, secure grip.
- Bring the chain saw to full rpm before starting the cut. Maintain full rpm until the cut is completely finished.
- Press spike rack against the limb or trunk.
- Apply a moderate amount of downward force to the saw.
- Cut straight through. Do not twist the saw during the cut.
- Be alert for the limb to shift, which may pinch the saw in the cut.
- Be alert for a limb or branch under tension to spring back when the cut is complete and the tension is released.

Figure 6

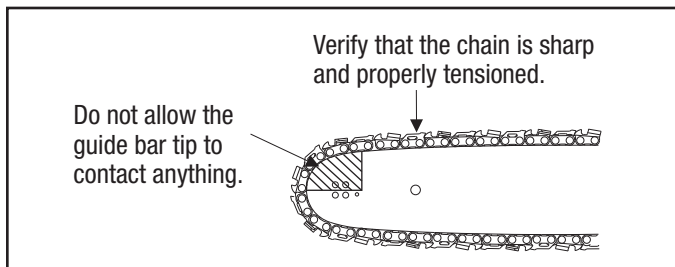
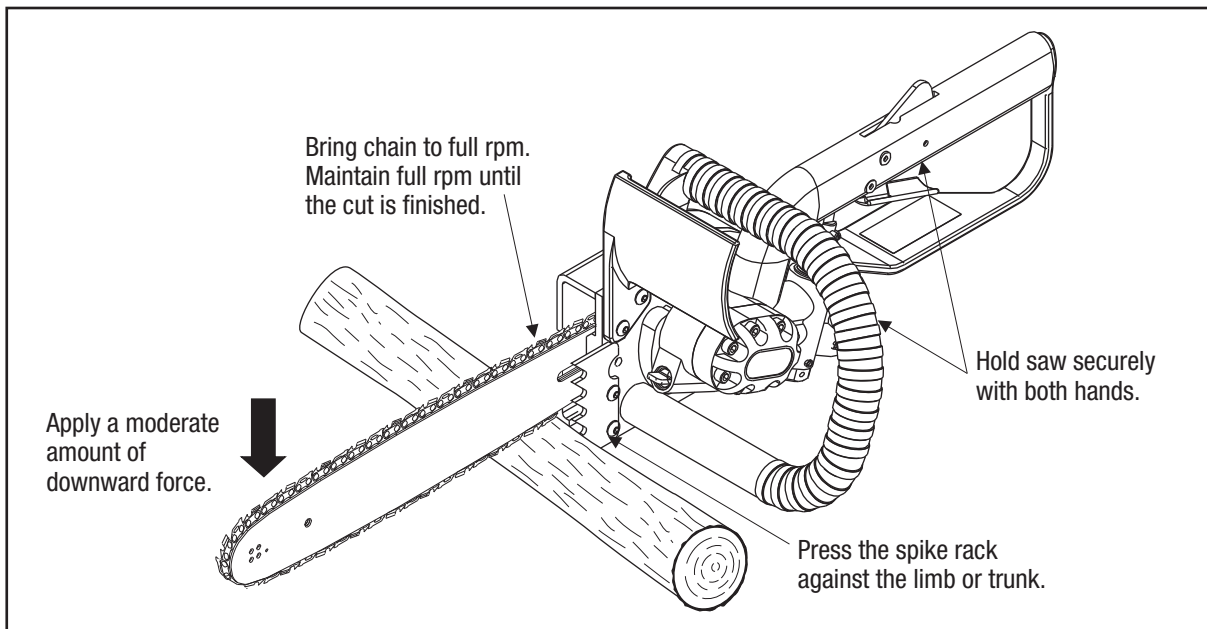

Figure 7 – Cutting Procedure



Chain Saw Basics (cont'd)

Site Preparation Tips

- Prepare the cutting area by clearing away brush, branches, vines, etc.
- Remove any unnecessary tools and coil up excess hydraulic hose.
- Survey the limb, branch or tree to predict the direction or path of fall. Be sure that no personnel are in that area.

Some factors that will influence the direction or path of fall of the tree include, but are not limited to:

- weight distribution of the limbs and branches. The weight distribution can be changed by pruning.
- the lean of the tree. A tree that leans will tend to fall in the direction it leans.
- wind direction. Do not fell a tree in strong winds.
- If working in a municipal area, plan the direction of fall so that a limb or tree doesn't fall into a roadway, strike a nearby building, contact nearby power lines, etc.
- If the tree is on an incline, work uphill from the fall path. A tree or branch might tend to bounce or roll downhill.
- Plan and clear two emergency exit routes, in case the tree falls in an unexpected direction.

COMPRESSION AND TENSION

Any branch or log will have two forces acting on it — compression and tension. As the branch or log is cut, compression tends to push the two halves toward each other. Tension tends to pull the two halves apart.

Refer to the illustrations. A log or limb supported at both ends has the compression on the top. A log or limb supported at one end has the compression on the bottom.

Make the first cut on the compression side. Cut through approximately 1/3 of the log's diameter. Make the second cut on the tension side. This will decrease the likelihood that the saw will become pinched in the cut.

Figure 8 – Compression on Top

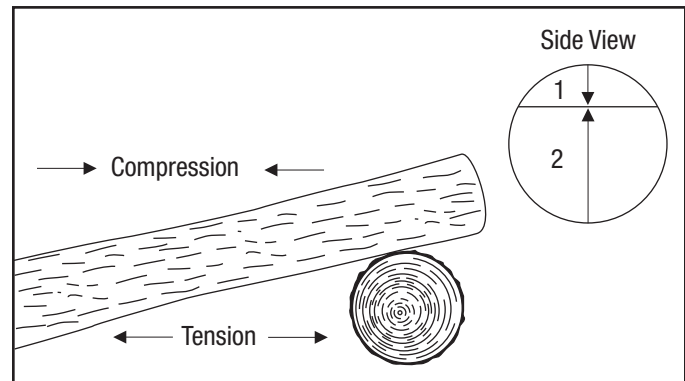
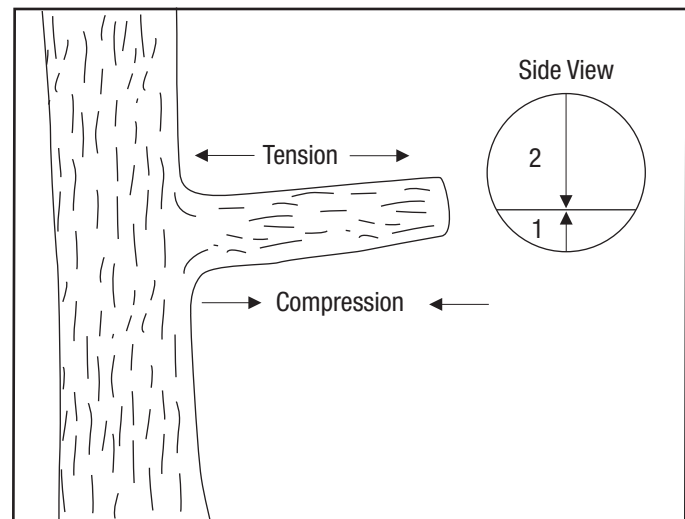

Figure 9 – Compression on Bottom



Chain Saw Basics (cont'd)

CUTTING TECHNIQUES

Pruning

Pruning is the process of cutting limbs or small branches off of a tree. Whenever possible, prune lower branches first so that higher branches have a clear fall path.

When pruning, the compression is along the bottom of the limb or branch. Make the first cut at the bottom, and final cut at the top of the branch.

Felling

Felling refers to cutting a tree down. Felling a tree consists of two cuts — a notch cut and a felling cut.

Begin by planning the direction of fall. Make the first cut — the notch cut — from the direction in which you want the tree to fall. After making the notch cut, remove the wedge-shaped piece of wood from the notch.

On the other side of the trunk, begin the felling cut approximately two inches above the bottom of the notch. Keeping two escape routes in mind, proceed with the felling cut. Do not cut completely through — leave approximately 1/10 of the diameter of the trunk to act as a hinge. This hinge will help to control the direction of fall.

Figure 10 – Felling

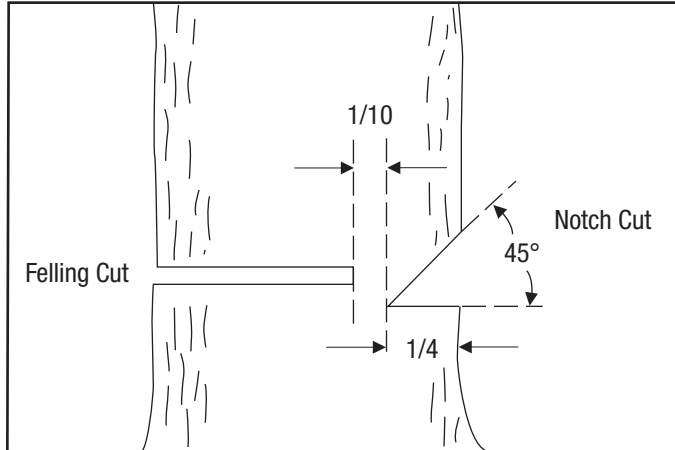

Limbing

Limbing is cutting limbs and branches from a fallen tree. Keep in mind that the trunk might shift as limbs are removed from it.

Remove limbs from the upper side of the trunk only. Then proceed to Bucking.

Bucking

Bucking refers to cutting the fallen tree into short sections. Make the first bucking cut on the compression side, and make the second cut on the tension side. Be aware that the section may fall in an unexpected direction when the cut is complete.

Sectioning

Sectioning is a method of bucking a fallen tree that is too large for a single pass of the saw. Refer to the illustrations below.

As always, make the first cuts on the compression side. Make the final cut on the tension side.

Figure 11 – Sectioning

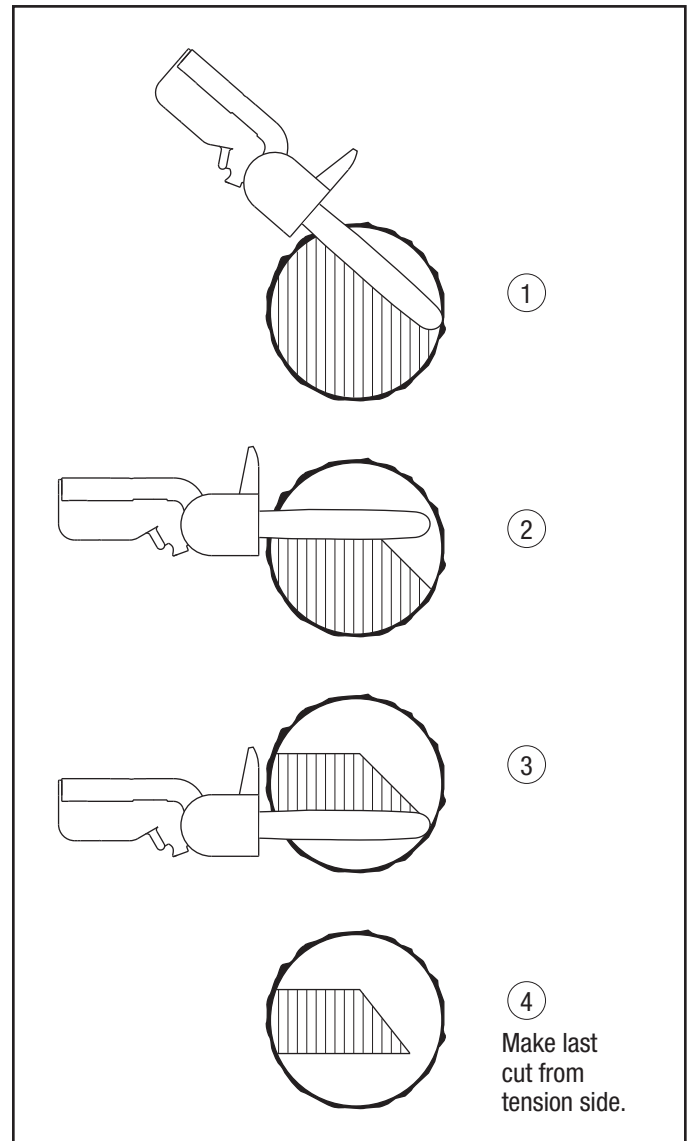

Handle Adjustment

⚠ WARNING

Do not change accessories, inspect, adjust or clean tool when it is connected to a power source. Accidental start-up can result in serious injury.

Failure to observe this warning could result in severe injury or death.

The control handle on this saw can be set to one of three positions — horizontal, 30°, or 60°. Choose the setting that maximizes cutting efficiency and operator comfort, based on the particular cutting task.

1. Remove the two knobs and cover.
2. Remove the two flange nuts, bar, and chain.

Figure 12

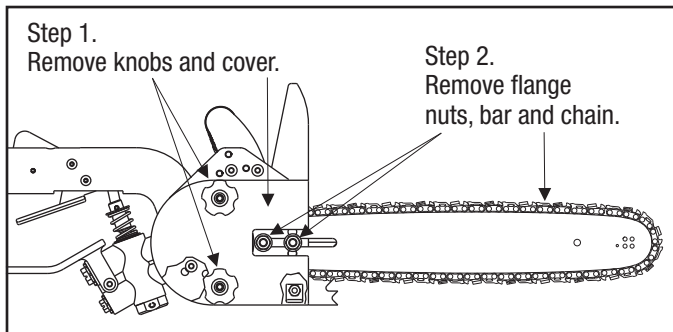

3. Remove the four 1/4–20 x .625 cap screws from the mount plate.

Figure 13

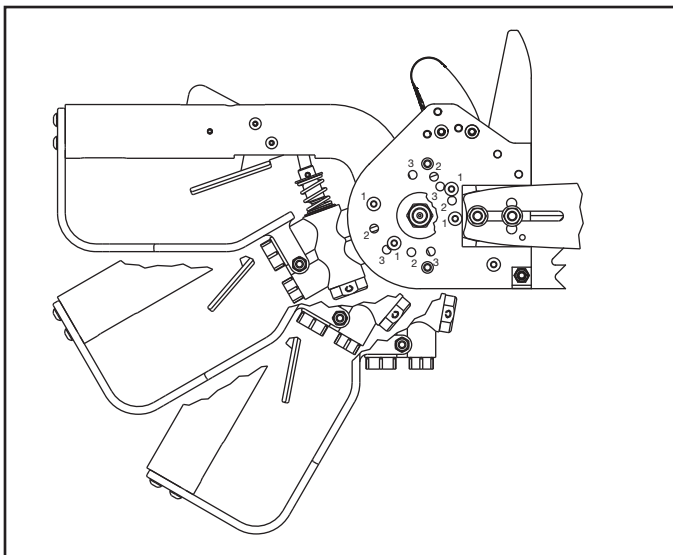

4. Set the handle to the new handle orientation.
 - Position #1: Horizontal
 - Position #2: 30°
 - Position #3: 60°
5. Apply a small amount of thread locking and sealing compound, such as Loctite® 242® Threadlocker or equivalent, to the threads in the mount plate and the threads of the cap screws. Follow the manufacturer's instructions for applying and curing. Tighten the cap screws to 9 to 10 newton-meters (80 to 90 in-lb).
6. Install the bar and chain onto the mount plate and secure loosely with two flange nuts. Ensure that the adjustment dog is located in the lowest hole in the bar.

Figure 14 – Bar Installation

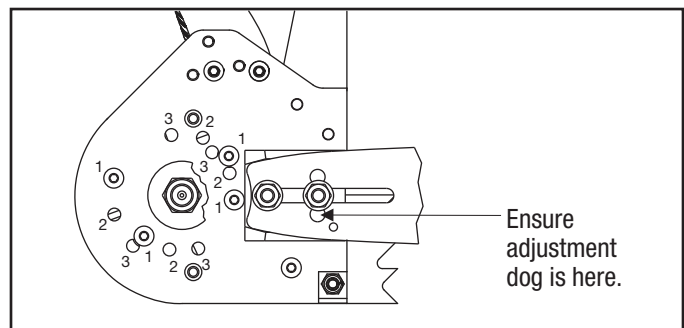
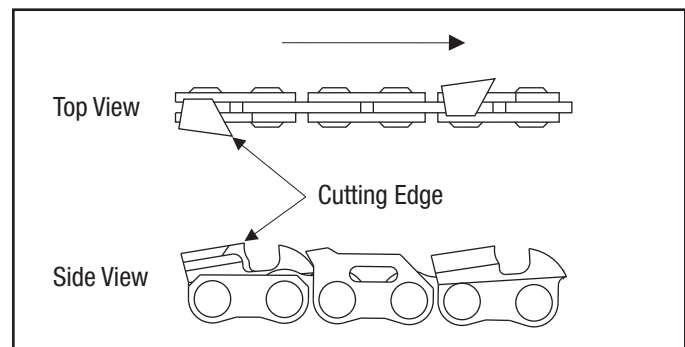

Figure 15 – Direction of Chain Travel



7. Adjust the tension — refer to “Adjusting Chain Tension” under “Saw Chain and Bar Maintenance.”
8. Install the cover over the standoffs and secure the cover with two cover knobs.

Setting the Super Spool™

The Super Spool™ allows the tool to be used with either Open-Center or Closed-Center hydraulic systems.

Open-Center Hydraulic System

Use a wrench to turn the Super Spool™ until the letter “O” on the spool is aligned with the letter “C” on the tool handle.

Closed-Center Hydraulic System

Use a wrench to turn the Super Spool™ until the letter “C” on the spool is aligned with the letter “C” on the tool handle.

Figure 16 – Setting the Super Spool™ Position

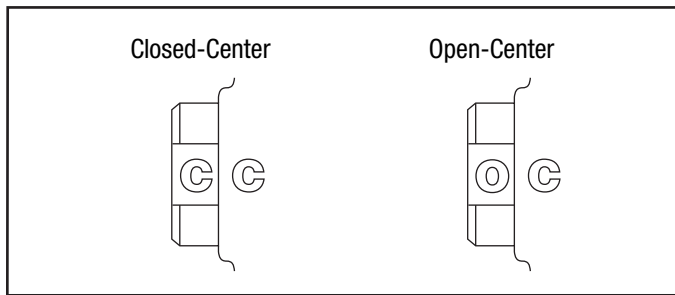

Hoses and Fittings

Installation and Maintenance

Refer to publication 99930323, SAE J1273 (Hose and Hose Assemblies).

Replacement

Refer to a Greenlee Utility catalog or Greenlee Utility publication 99910322, Low Pressure Quick Couplers, Adapters and Hoses.

Hose Connections

Tool Port Identification

One of three methods is used to identify the pressure and tank ports of Greenlee Utility tools. Match your tool to this table.

Pressure Port	Tank Port
P	T
or	
In	Out
or	
9/16"–18 SAE O-ring Boss (smaller port)	3/4"–16 SAE O-ring Boss (larger port)

Connecting Hoses

1. Move the flow lever on the hydraulic power source to the OFF position.
2. Stop the hydraulic power source.
3. Connect the tank hose to the tank (or return) port on the power source, and then to the tank port on the tool.
4. Connect the pressure hose to the pressure port or hose coupler on the tool, and then to the pressure port on the power source.

Disconnecting Hoses

1. Move the flow lever on the hydraulic power source to the OFF position.
2. Stop the hydraulic power source.
3. Disconnect the pressure hose from the power source, and then from the tool.
4. Disconnect the tank hose from the tool, and then from the power source.
5. Install dust caps over the ports to prevent contamination.

Typical Setup

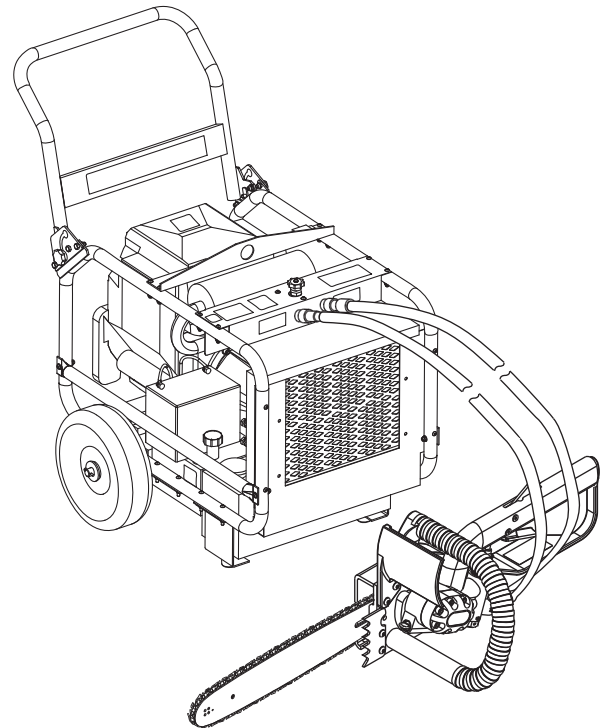



Operation

	⚠ WARNING
	<p>Electric shock hazard:</p> <p>This tool is not insulated. When using this unit near energized electrical lines, use only certified non-conductive hoses and proper personal protective equipment.</p> <p>Failure to observe this warning could result in severe injury or death.</p>

	⚠ WARNING
	<p>Skin injection hazard:</p> <p>Oil under pressure easily punctures skin causing serious injury, gangrene or death. If you are injured by escaping oil, seek medical attention immediately.</p> <ul style="list-style-type: none"> • Do not use fingers or hands to check for leaks. • Do not hold hose or couplers while the hydraulic system is pressurized. • Depressurize the hydraulic system before servicing.

	⚠ WARNING
	<p>Saw body, bar, blade and other components will be hot during and after use. Use care when handling the saw. Hot surfaces can cause serious burns.</p> <p>Failure to observe this warning could result in severe injury or death.</p>

	⚠ WARNING
	<p>Before operating the saw, read and understand the following explanations in this manual:</p> <ul style="list-style-type: none"> • Pull-In Pull-in can occur when the blade at the bottom of the bar contacts a foreign object, such as a nail, or when the blade is pinched in the cut. The saw will be suddenly and forcefully pulled away from the operator. • Push-back Push-back can occur when the blade at the top of the bar contacts a foreign object, such as a nail, or when the blade is pinched in the cut. The saw will be suddenly and forcefully pushed back toward the operator. • Kickback Kickback can occur when the chain at the guide bar tip contacts anything. The bar of the saw will travel upward and back, toward the operator. <p>Failure to observe this warning could result in severe injury or death.</p>

	⚠ WARNING
	<p>Wear a hard hat when using this tool.</p> <p>Failure to observe this warning could result in severe injury or death,</p>

Operation (cont'd)

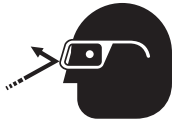
	⚠ WARNING
	<p>Wear eye protection when operating or servicing this tool.</p> <p>Failure to wear eye protection could result in serious eye injury from flying debris or hydraulic oil.</p>

	⚠ WARNING
	<p>Wear hearing protection when using this tool.</p> <p>Long-term exposure to high noise levels could result in hearing loss.</p>

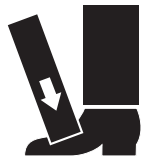
	⚠ WARNING
	<p>Wear foot protection when using this tool.</p> <p>Failure to observe this warning could result in serious injury.</p>

⚠ WARNING
<p>Do not disconnect tool, hoses or fittings while the power source is running or if the hydraulic fluid is hot. Hot hydraulic fluid could cause serious burns.</p>

⚠ CAUTION
<p>Vibration hazard:</p> <p>Apply just enough pressure to do the work. Applying excess pressure to the tool can cause operator discomfort or temporary numbness.</p> <p>Failure to observe this precaution can result in injury.</p>

IMPORTANT
<ul style="list-style-type: none"> • Check the operation of the automatic oiler frequently. Refer to “Checking and Setting the Automatic Chain Oiler” in this manual. • Check the chain frequently for proper tension and sharpness. Tension and sharpen as necessary. Refer to the instructions under “Saw Chain and Bar Maintenance.” • Check the fluid level of the power source reservoir frequently. The automatic oiler uses hydraulic fluid to lubricate the bar and chain, and will cause the fluid level to drop.

IMPORTANT
<p>Emergency stop procedure:</p> <ol style="list-style-type: none"> 1. Release the trigger. 2. Shut off the hydraulic power source.

1. Grasp the front handle with your left hand and the trigger handle with your right hand.
Note: These hand placement instructions are for both right-handed and left-handed users.
2. Press down on the trigger actuator and pull the trigger until the saw reaches full rpm.
3. Feed the rotating saw chain using a steady, constant pressure.
Note: Cut straight through the wood — do not twist the saw in the cut.
4. To stop the saw, release the trigger.
5. When the tool is not in use, stop the power source to reduce heat and wear.

Maintenance

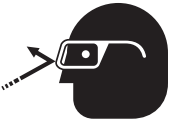
	⚠ WARNING
	<p>Wear eye protection when operating or servicing this tool.</p> <p>Failure to wear eye protection could result in serious eye injury from flying debris or hydraulic oil.</p>

⚠ WARNING
<p>Do not reverse hydraulic flow. Operation with hydraulic flow reversed could cause tool malfunction. Connect the pressure hose and tank hose to the proper ports.</p>

SCHEDULE

Use this schedule to maximize the tool's service life.

Notes: Keep all decals clean and legible. Replace decals when necessary.

When disposing of any components (hydraulic hoses, hydraulic fluid, worn parts, etc.), do so in accordance with federal, state and local laws or ordinances.

Daily

1. Wipe all tool surfaces clean.
2. Inspect the entire chain before use. Tension and sharpen the chain as instructed under Saw Chain and Bar Maintenance. An improperly sharpened, dull, worn or damaged chain increases the risk of kickback.
3. Check the operation of the automatic oiler before use as instructed under Checking and Setting the Automatic Chain Oiler. An improperly set oiler can accelerate the wear of the chain and bar.
4. Inspect the hydraulic hoses and fittings for signs of leaks, cracks, wear or damage. Replace if necessary.
5. Install dust caps over the hydraulic ports when the tool is disconnected.

Monthly

1. Perform a thorough inspection of the hydraulic hoses and fittings as described in publication 99930323, SAE J1273 (Hose and Hose Assemblies).
2. Perform the Bar Service procedure as described under Saw Chain and Bar Maintenance.

Annually

If required by your organization's regulations, have the tool inspected by an Greenlee Utility authorized service center.

CHECKING AND SETTING THE AUTOMATIC CHAIN OILER

The automatic chain oiler provides a constant supply of oil to lubricate the bar and chain whenever the saw is operating. An adjustment screw controls the amount of oil supplied.

1. Run the saw at full rpm.
2. If the tip of the saw gives off a fine spray of oil, the automatic oiler is working properly. If the saw does not give off a spray of oil, adjust the oiler.

Note: For better results, hold saw so that the tip of the saw blade is pointing toward a clean sheet of paper or cardboard and run the saw at full rpm. If the automatic oiler is working properly, the paper or cardboard should soon show small droplets of oil.

3. Stop the hydraulic power source.
4. Twist the adjustment screw 1/2 turn as follows:
 - clockwise to decrease the oiler output.
 - counterclockwise to increase the oiler output.

Figure 17 – Automatic Oiler Adjustment Screw

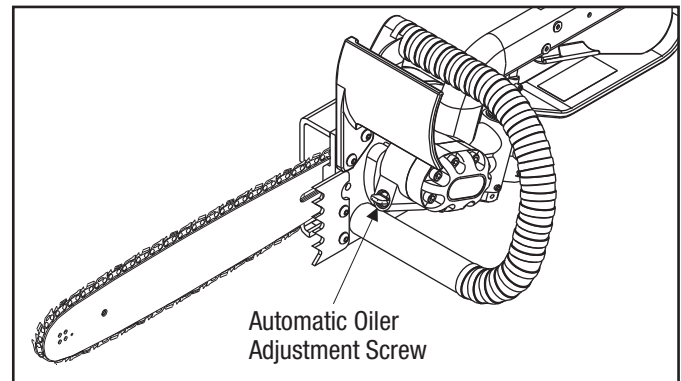

5. Start the hydraulic power source.
6. Repeat until the oiler output is adjusted correctly.

Maintenance (cont'd)

SAW CHAIN AND BAR MAINTENANCE

New Chain Break-In

1. Run the saw at low chain speed without cutting wood for 2 to 3 minutes. Check the output from the automatic oiler.
2. Stop the hydraulic power source. Disconnect the hoses. Allow the bar and chain to cool. Check the tension and adjust if necessary.
3. Connect the hoses. Start the power source. Make a few easy cuts at moderate chain speed.
4. Stop the hydraulic power source. Disconnect the hoses. Allow the bar and chain to cool. Check the tension and adjust if necessary.
5. Connect the hoses. Start the power source. Use the saw for moderate cuts during the next 30 minutes of use.

Checking Chain Tension

1. Stop the hydraulic power source. Disconnect the hoses. Allow the bar and chain to cool.
2. Pull the saw chain around the bar. The chain should rotate around the bar easily. If it does not, refer to "Chain is Difficult to Rotate Manually" in the Troubleshooting table.
3. Check the tension as follows:
Pull the saw chain away from the bar (refer to the illustration) using approximately 4.4 newtons (2 lb) of force. The clearance between the chain and bar should be approximately 3.2 mm (1/8"). If there is too much or too little clearance, proceed to "Adjusting Chain Tension."

Figure 18 – Proper Chain Tension

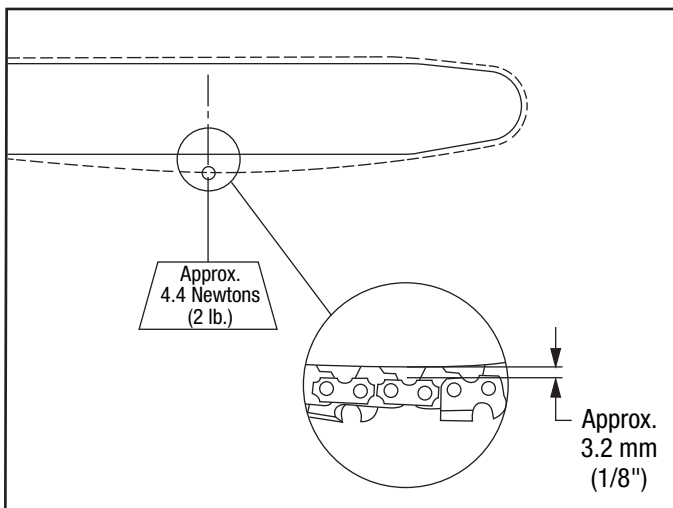

Adjusting Chain Tension

1. Loosen the two bar flange nuts.
2. Turn the saw chain tension adjusting screw until the proper tension is achieved, as follows:
Pull the saw chain away from the bar (refer to the illustration) using approximately 4.4 newtons (2 lb) of force. The clearance between the chain and bar should be approximately 3.2 mm (1/8").
3. Hold the bar nose up and tighten the two bar flange nuts. Torque to 16.9 newton-meters (150 in-lb).
4. Check the chain tension again.
5. Rotate the chain around the bar manually. If you hear a clicking noise, the chain drive links are hitting the bar. Repeat the "Adjusting Chain Tension" procedure.

Bar Service

1. Mark the top side of the bar with a grease pencil or marker.
2. Remove the chain and bar. Use a small cleaning brush to remove all residue from the bar groove.
3. Clean the oil passage at the base of the guide bar. Use any instrument small enough to thoroughly clean the passage.
4. Check the bar rails for wear by placing a straight edge against the side of the bar and one cutter. Refer to Figure 19.
 - Clearance between the bar and straight edge indicates that the bar rails are not worn.
 - If the chain leans and there is little or no clearance between the bar and straightedge, the bar rails are worn and the bar should be replaced.

Figure 19 – Checking Rails for Wear

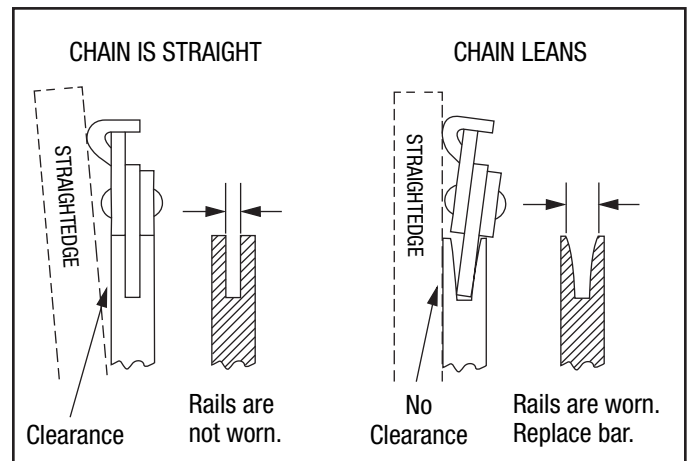

Maintenance (cont'd)

5. Inspect the rim sprocket and sprocket adapter.
Replace if worn or damaged. Refer to Figure 20.

Figure 20 – Rim Sprocket and Sprocket Adapter

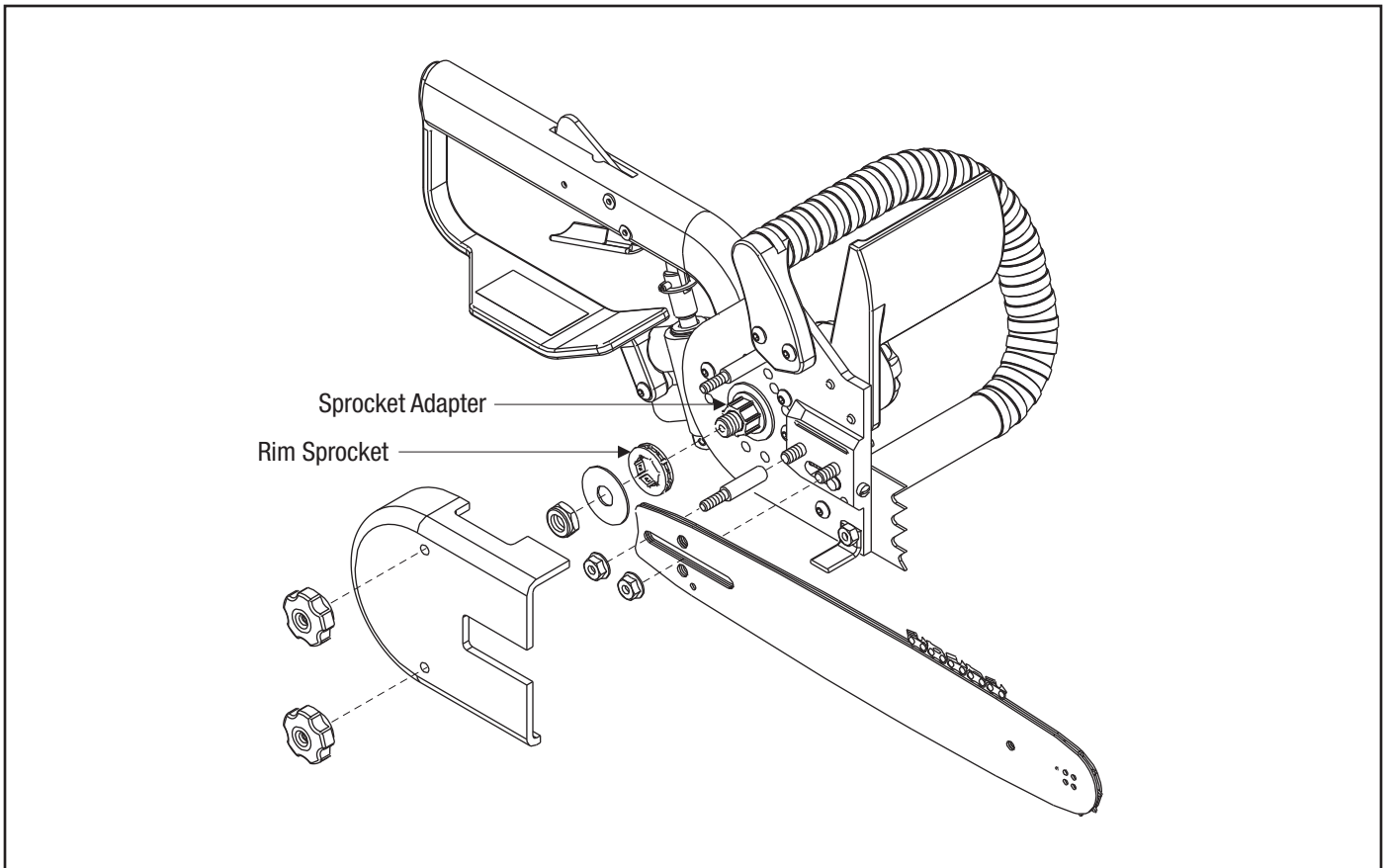

6. Use the mark made in Step 1 to install the bar upside down, so that the bar will wear evenly.
7. Install the chain as shown in Figure 21. Adjust the tension of the chain as described under "Adjusting Chain Tension."

Figure 21 – Direction of Chain Travel

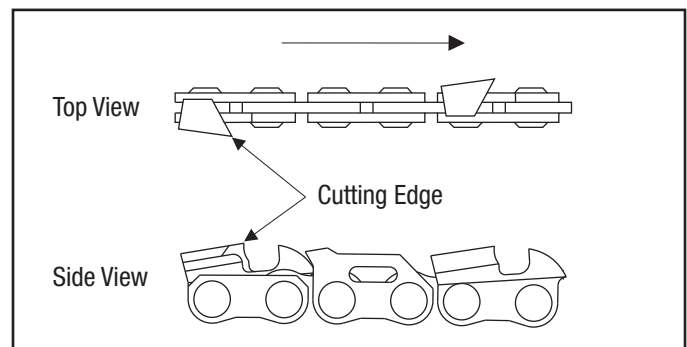

Maintenance (cont'd)

SHARPENING THE SAW CHAIN

The saw chain must be sharpened to the manufacturer's specifications. If the saw chain is not properly sharpened, the risk of kickback increases.

If using a filing guide or hand-held grinder, refer to the manufacturer's instructions provided with the unit.

Refer to Illustration →		Figure A	Figure B	Figure C	Figure D	Figure E	—	Figure F	—
Model Number	Chain Part Number	Pitch	Gauge	Side Plate Angle	Top Plate Cutting Angle	Top Plate Filing Angle	File Guide Angle	Depth Gauge Setting	Round File Size
HPS513	50433709	.325"	.058"	85°	60°	30°	10°	.025"	3/16"
HCS816	50419600	3/8"	.050"	60°	60°	25°	10°	.025"	7/32"
HCS820	90551915	3/8"	.050"	60°	60°	25°	10°	.025"	7/32"

Saw Chain Pitch

Refer to Figure A. Pitch refers to the saw chain measurement. A chain's pitch is the distance between any three consecutive rivets divided by two. Example: .65 divided by two equals .325 pitch.

Saw Chain Gauge

Refer to Figure B. Gauge refers to the thickness of that portion of the drive link which fits into the guide bar groove. The guide bar and saw chain gauge must match. Industry standards are .050, .058 and .063.

Figure A – Pitch

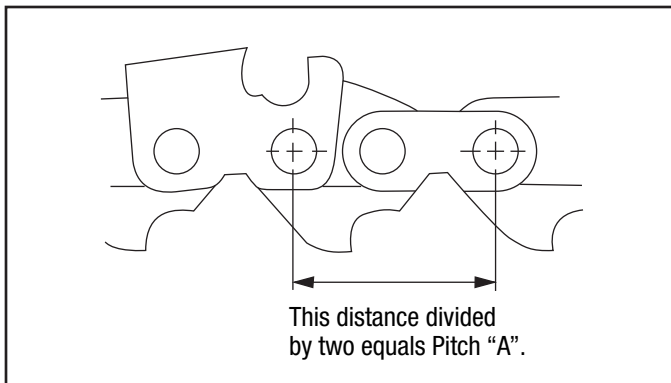

Figure B – Gauge

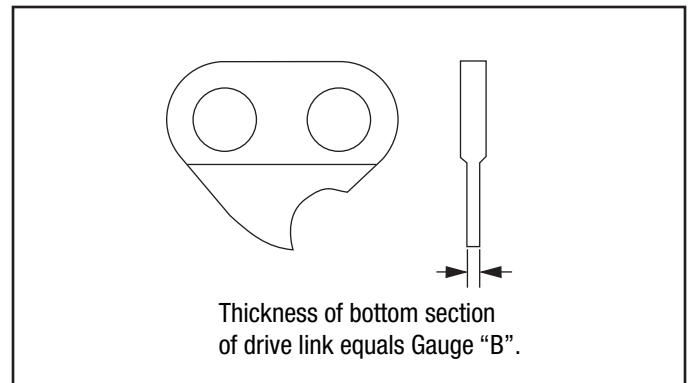

Figure C
Side Plate Angle

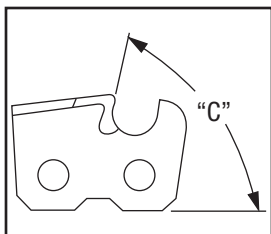

Figure D
Top Plate Cutting Angle

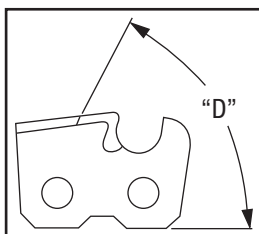
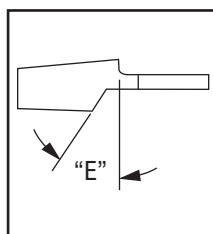

Figure E
Top Plate Filing Angle



File Guide Angle

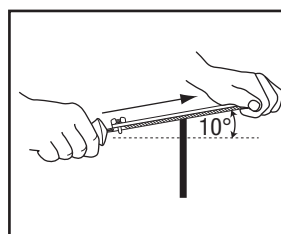
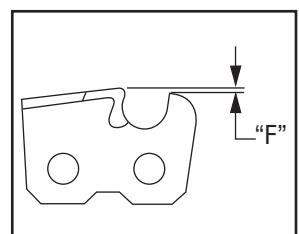

Figure F
Depth Gauge Setting



Maintenance (cont'd)

Filing Depth Gauges

1. If the cutters are sharpened with a file holder, check and lower the depth gauges before sharpening the cutters.
2. Check the depth gauges every third sharpening.
3. Refer to Figure 22. Place the depth gauge tool on the cutter. If the depth gauge projects, file it level with the top of the tool. Always file from the inside of the saw chain toward an outside cutter.

Figure 22 – Lowering Depth Gauges

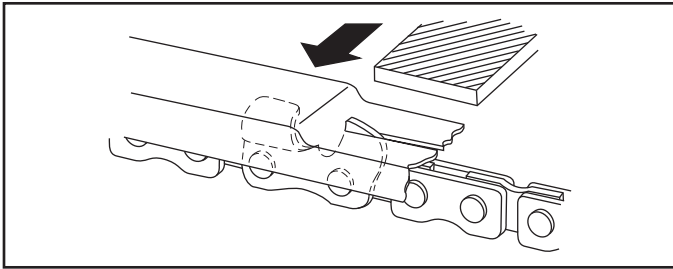

4. Refer to Figure 23. Round off the front corner to maintain the original shape of the depth gauge after using the depth gauge tool. Always follow the recommended depth gauge setting of the chain manufacturer. This is important for maximum performance throughout the saw chain's life as well as for protection against kickback.

Figure 23 – Rounding Off Depth Gauges

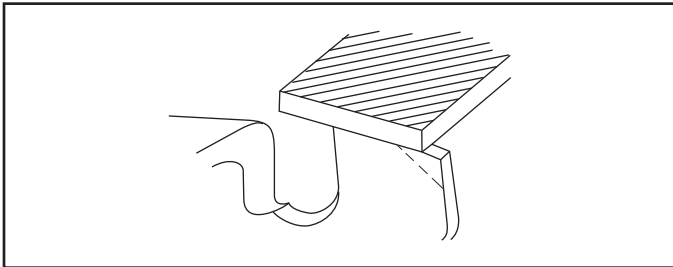

Filing Cutters – General

1. Refer to Figure 24. Support the file holder on the cutter top plate and depth gauge as shown.

Figure 24 – Filing Cutters

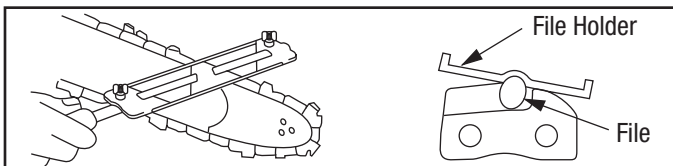

2. Refer to Figure 25. Guide the file at a 10° angle to the cutters.

Figure 25 – File Guide Angle

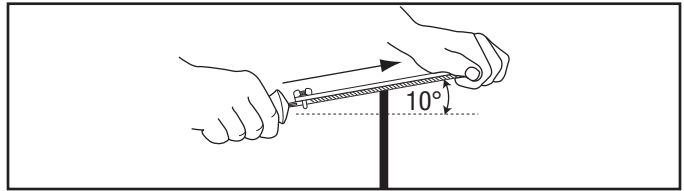

3. Refer to Figure 26. File the cutters on one side of the saw chain from the inside out. File on the forward stroke only.

Figure 26 – Filing Cutters

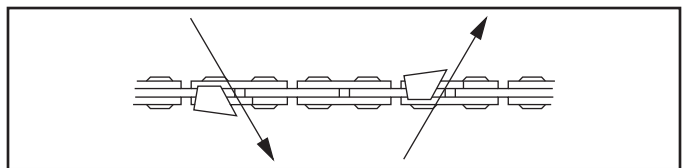

4. Refer to Figure 27. Keep the line on the file holder parallel to the center of the saw chain. Reverse the procedure for the other side.

Figure 27 – Filing Cutters

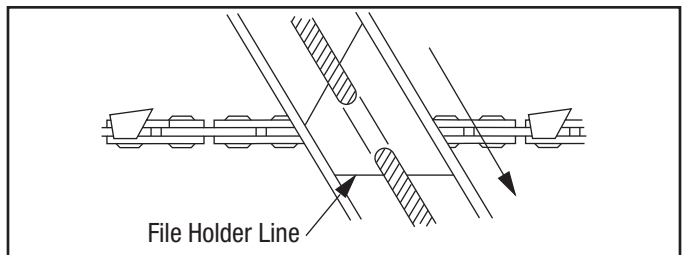

5. Refer to Figure 28. Keep all cutters the same length.

Figure 28 – Filing Cutters

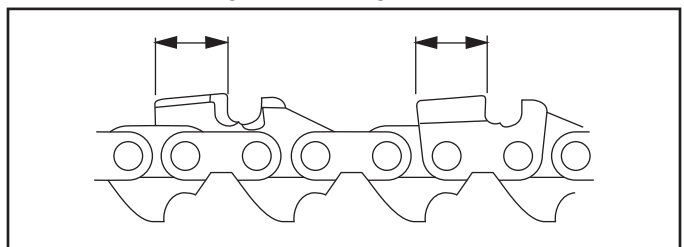

6. Refer to Figure 29. File enough to remove any damage to the cutting edges (side plate and top plate) of the cutter.

Figure 29 – Filing Cutters

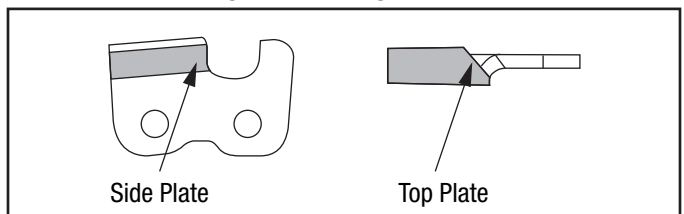

Troubleshooting

Before troubleshooting, determine whether the problem is in the tool, the hoses, or the power source. Substitute a tool, hoses, or power source known to be in good working order to eliminate the item that is not operating.

If the problem is in the tool, refer to the troubleshooting table in this manual. If the problem is in the power source, refer to the troubleshooting section of the power source instruction manual.

Problem	Probable Cause	Probable Remedy
Tool does not operate.	Improper power source.	Verify that the power source meets the specifications. Refer to the "Specifications" section.
	Hydraulic fluid level low.	Check the fluid level. Check system for leaks.
	Incorrect hydraulic fluid viscosity.	Use hydraulic fluid with the correct viscosity. Refer to the "Specifications" section.
Tool operates slowly or erratically.	Hydraulic fluid cold.	Allow fluid to warm to the operating temperature. Actuate the tool intermittently to reduce the warming time.
	Power source not adjusted correctly.	Refer to the power source operator's manual. Set the flow and pressure to correspond with the tool.
	Hydraulic fluid level low.	Check the fluid level. Check system for leaks.
	Air in the hydraulic system.	Refer to power source manufacturer's instructions for removing air from the system.
	Incorrect hydraulic fluid viscosity.	Use hydraulic fluid with the correct viscosity. Refer to the "Specifications" section.
Trigger difficult to operate; trigger sticks when released.	Dirt or gummy deposits on trigger or spool.	Clean and lubricate trigger and trigger spool.
Chain runs in wrong direction.	Hose connections at tool are reversed.	Depressurize hydraulic system. Switch the hose connections.

Troubleshooting (cont'd)

Problem	Probable Cause	Probable Remedy
Chain does not cut.	Chain dull.	Remove chain and sharpen to chain manufacturer's specifications or replace with a sharp chain.
	Too much tension on the chain.	Adjust chain tension. Refer to "Saw Chain and Bar Maintenance."
	Automatic oiler not lubricating chain and bar.	Refer to "Checking and Setting the Automatic Chain Oiler."
	Chain installed backward.	Remove chain and install correctly.
	Guide bar worn.	Inspect guide bar rails for wear. Refer to "Saw Chain and Bar Maintenance." If excessively worn, replace guide bar.
Tool feels hot.	Hydraulic fluid level low.	Check the fluid level. Check system for leaks.
	Incorrect hydraulic fluid viscosity.	Use hydraulic fluid with the correct viscosity. Refer to the "Specifications" section.
	Hydraulic fluid dirty.	Refer to the power source owner's manual for procedure to replace hydraulic oil and filter.
Chain is difficult to rotate manually.	Hydraulic pressure trapped in saw motor.	Release hydraulic pressure by using proper hose disconnection procedure. Refer to "Hose Connection" in this manual.
	Chain and bar improperly adjusted.	Refer to "Adjusting Chain Tension" under "Saw Chain and Bar Maintenance" in this manual.
	Chain drive links damaged.	Remove chain and inspect drive links.
	Bar groove damaged.	Remove chain and inspect bar groove.

Illustration

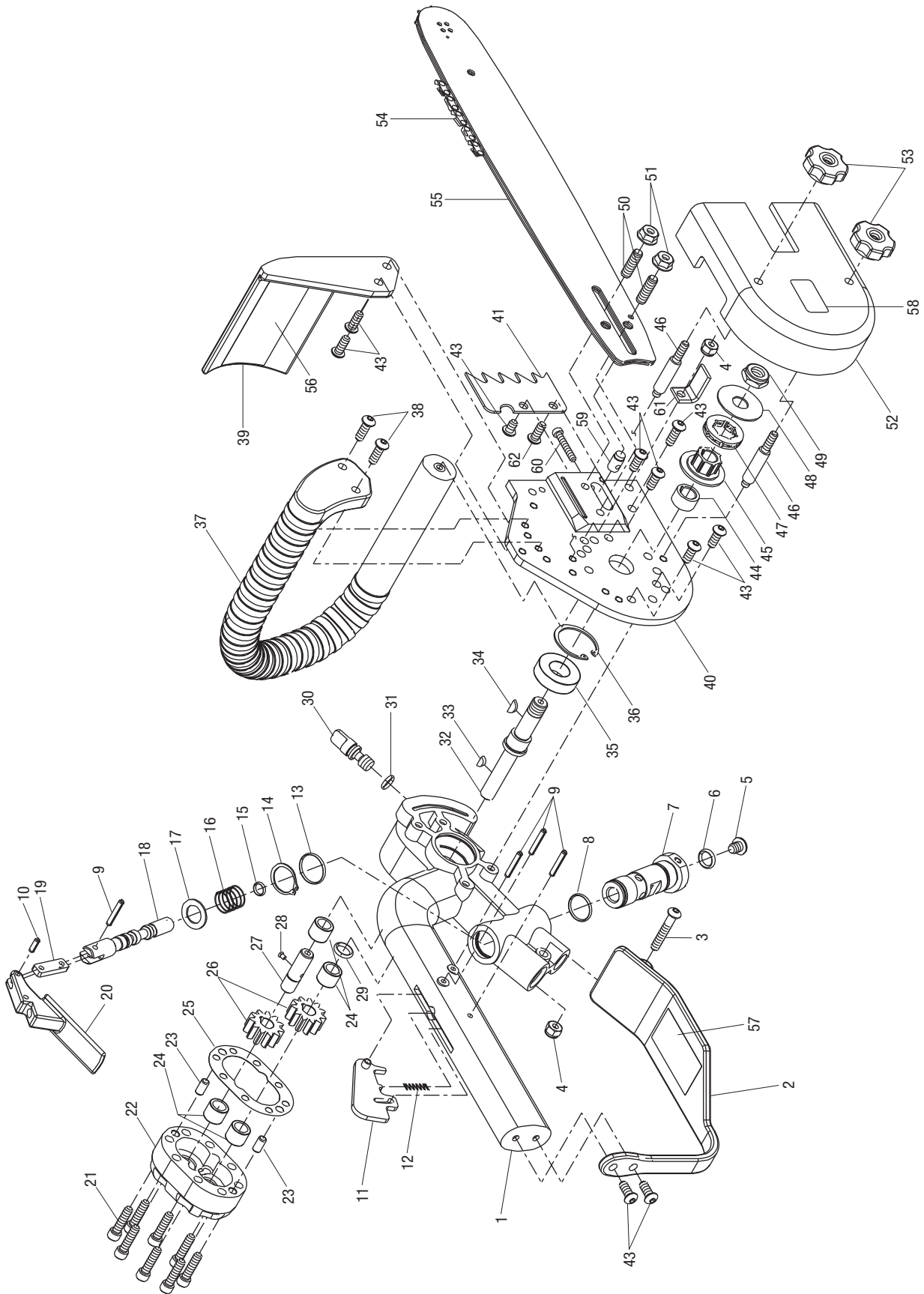

Parts List

Key	UPC No. 78-3310-	Part No.	Description	Qty
1	49453	50494538	Head, saw	1
2	49757	50497570	Handle, lower (includes #57)	1
3			Screw, cap, 1/4-20 x 1.50", button head socket	1
4	43997	50439979	Nut, hex, 1/4-20 lock, stainless steel	2
5			Screw, cap, 5/16-18 x .375" button head socket	1
6 *			O-ring, .437" x .625" x .093"-90	1
7	49415	50494155	Sleeve	1
8 *			O-ring, .750" x .875" x .062"-90	1
9	43622	50436228	Pin, roll, .156" x 1.00"	4
10	50196	90501969	Pin, roll, .156" x .500"	1
11	49408	50494082	Actuator, trigger	1
12	54144	90541448	Spring, compression, .248" x .300" x .690"	1
13 *			O-ring, .875" x 1.00" x .062"-70	1
14	41298	50412981	Ring, retaining, .875", external	1
15 *			O-ring, .312" x .437" x .062"-70	1
16	41760	50417601	Spring, compression, .675" x .845" x 1.25"	1
17	40462	50404622	Washer, flat, .580" x .937" x .050", stainless steel	1
18	49416	50494163	Spool	1
19	49409	50494090	Link	1
20	49407	50494074	Trigger	1
21	41616	50416162	Screw, cap, 1/4-20 x 1.00", socket head	8
22	40412	50404124	Cap, motor (includes 2 of item 24)	1
23	41596	50415960	Pin, dowel, .250" x .500"	2
24	41591	50415911	Bearing, needle, .439" x .625" x .500"	4
25 *			Gasket, 2.09" x 3.09" x .0015"	1
26	41630	50416302	Gear, 11-tooth	2
27	40168	50401682	Shaft, idler	1
28	41593	50415930	Pin, drive, .123" x .209" w/ square head	1
29 *			O-ring, .500" x .687" x .093"-80	1
30	49419	50494198	Bleed screw	1
31 *			O-ring, .375" x .500" x .062"-70	1
32	49417	50494171	Shaft, drive	1
33	41592	50415921	Key, Woodruff #213	1
34	41813	50418131	Key, Woodruff #2	1
35	41598	50415981	Bearing, ball	1
36	41482	50414821	Ring, retaining	1
37	49404	50494040	Handle, front	1
38			Screw, cap, 1/4-20 x .750", button head	3
39	49758	50497588	Shroud (includes #56)	1
40	45432	50454323	Plate, mount	1
41	49403	50494031	Rack, spike	1
43			Screw, cap, 1/4-20 x .625", button head	10
44	49418	50494180	Spacer, drive shaft	1
45	55102	90551028	Adapter, sprocket	1
46	55137	90551370	Standoff	2
47	55101	90551010	Rim sprocket, .325" pitch (HPS513)	1
	55103	90551036	Rim Sprocket, 3/8" Pitch (HCS816 and HCS820)	1
48	43309	50433091	Washer, flat, .530" x 1.50" x .050"	1
49			Nut, hex, 1/2-20, lock	1
50	55104	90551044	Stud, threaded, 5/16-18 x 1.00"	2
51			Nut, hex, 5/16-18, flange	2
52	49405	50494058	Cover	1

Parts List (cont'd)

Key	UPC No. 78-3310-	Part No.	Description	Qty
53	55099	90550994	Knob, knurled, 1/4-20 x 1.00"	2
54	43370	50433709	Chain, 13" x .058" Ga., .325" pitch (HPS513).....	1
	41960	50419600	Chain, 16" x .050" Ga., 3/8" pitch (HCS816)	1
	55191	90551915	Chain, 20" x .050" Ga., 3/8" pitch (HCS820)	1
55	43369	50433695	Bar, guide, 13" x .058" Ga (HPS513)	1
	55141	90551419	Bar, guide, 16" x .050" Ga (HCS816)	1
	55185	90551850	Bar, guide, 20" x .050" Ga (HCS820)	1
59	49461	50494619	Dog, adjustment	1
60	55139	90551397	Screw, #10-24 x 2.00", fillister head	1
61	49414	50494147	Catcher, chain	1
62			Screw, cap, 1/4-20 x .88, button head.....	1
	40305	50403054	12" hose assembly, 9/16-18 thrd.....	1
	40307	50403073	12" hose assembly, 3/4-16 thrd.....	1
Decals				
56*	49567	50495674	Decal, warning	1
57*	49568	50495682	Decal, pressure, flow.....	1
58	41547	50415471	Decal, Greenlee Utility.....	1
Repair Kit				
*	40789	50407891	Packing kit (includes all items marked with an asterisk).....	1

Accessories

These chain saws will accept any of the following combinations of bar, chain and rim sprocket.

Description			Part Number		
Bar Length	Bar and Chain Gauge	Chain and Sprocket Pitch	Bar	Chain	Sprocket
16"	.050"	3/8"	90551419	50419600	90551036
20"	.050"	3/8"	90551850	90551915	90551036



4455 Boeing Drive • Rockford, IL 61109-2988 • USA • 815-397-7070
An ISO 9001 Company • Greenlee Textron Inc. is a subsidiary of Textron Inc.

www.greenlee.com

USA Tel: 800-435-0786
Fax: 800-451-2632

Canada Tel: 800-435-0786
Fax: 800-524-2853

International Tel: +1-815-397-7070
Fax: +1-815-397-9247