

**Submission Package**

# Engineering Specification, Installation, Operation and Maintenance Model LFM115-3 / LFM6115-3

## Pressure Reducing Control Valve with Hydraulic Check Feature

Sizes: 1¼" to 24"

**⚠ WARNING**



**Read this Manual BEFORE using this equipment. Failure to read and follow all safety and use information can result in death, serious personal injury, property damage, or damage to the equipment. Keep this Manual for future reference.**

**THINK SAFETY FIRST**

**⚠ WARNING**

Local building or plumbing codes may require modifications to the information provided. You are required to consult the local building and plumbing codes prior to installation. If the information provided here is not consistent with local building or plumbing codes, the local codes should be followed. This product must be installed by a licensed contractor in accordance with local codes and ordinances.

**⚠ WARNING**

**Need for Periodic Inspection/Maintenance:** This product must be tested periodically in compliance with local codes, but at least once per year or more as service conditions warrant. All products must be retested once maintenance has been performed. Corrosive water conditions and/or unauthorized adjustments or repair could render the product ineffective for the service intended. Regular checking and cleaning of the product's internal and external components helps assure maximum life and proper product function.

**NOTICE**

For Australia and New Zealand: Pipeline strainers should be installed between the upstream shutoff valve and the inlet of the backflow preventer.

It's important that this device be tested periodically in compliance with local codes, but at least once per year or more as service conditions warrant. If installed on a fire sprinkler system, all mechanical checks, such as alarm checks and backflow preventers, should be flow tested and inspected internally in accordance with NFPA 13 and NFPA 25.

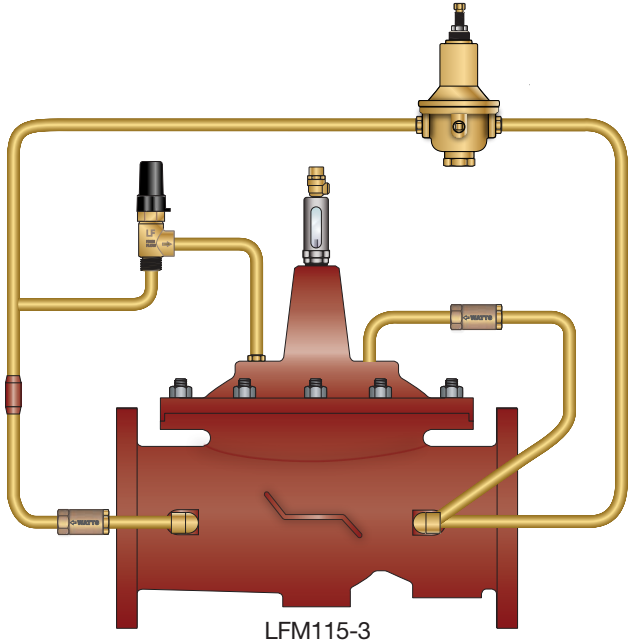

Table of Contents	Page
<b>Engineering Specifications</b>	
<a href="#">ACV Schematic</a> .....	2
<a href="#">Basic Valves</a> .....	3
<a href="#">Standard Components</a> .....	7
<a href="#">Optional Components</a> .....	10
<b>Installation, Operation and Maintenance</b>	
<a href="#">Installation</a> .....	15
<a href="#">Valve Servicing Dimensions</a> .....	15
<a href="#">Setting the Pressure Reducing Control</a> .....	16
<a href="#">ACV Maintenance Schedule</a> .....	18
<a href="#">Troubleshooting Guide</a> .....	19
<a href="#">Valve Disassembly Instructions</a> .....	20

Watts product specifications in U.S. customary units and metric are approximate and are provided for reference only. For precise measurements, please contact Watts Technical Service. Watts reserves the right to change or modify product design, construction, specifications, or materials without prior notice and without incurring any obligation to make such changes and modifications on Watts products previously or subsequently sold.



**LEAD FREE\***

## Series LFM115-3

### Pressure Reducing Control Valve with Hydraulic Check Feature

#### Full Port Ductile Iron Single Chamber Valve

#### Features

- Throttles to reduce high upstream pressure to constant lower downstream pressure
- Hydraulic Check Feature prevents flow reversal
- Reducing setpoint is adjustable

#### Standard Components

- 1 – Main Valve (M100 – Single Chamber)
- 2 – Pressure Reducing Control
- 3 – Check Valve
- 4 – Fixed Orifice
- X – Isolation Cocks

#### Options and Accessories

- FC Flo-Clean Strainer (Standard 1¼" – 4")
- Y Y-Strainer (Replaces Flo-Clean)
- ACS Adjustable Closing Speed (Replaces Fixed Orifice)
- AOS Adjustable Opening Speed (Standard 1¼" – 4")
- P Position Indicator
- L Limit Switch

#### Operation

The Combination Pressure Reducing and Check Automatic Control Valve (ACV) is designed to automatically reduce a fluctuating higher upstream pressure to a constant lower downstream pressure, and close drip-tight when downstream pressure becomes greater than upstream pressure.

It is controlled by a normally open, pressure reducing pilot designed to: 1) Open (allowing fluid out of the main valve cover chamber) when downstream pressure is below the adjustable setpoint, and 2) Close (allowing fluid to fill the main valve cover chamber) when downstream pressure is above the adjustable setpoint. A decrease in downstream pressure causes the valve to modulate toward an open position, raising downstream pressure. An increase in downstream pressure causes the valve to modulate toward a closed position, lowering downstream pressure.

If downstream pressure becomes greater than upstream pressure, downstream pressure is admitted to the main valve cover chamber, closing the valve and preventing reversal of flow. Normal pressure reducing operation resumes when upstream pressure exceeds downstream pressure.

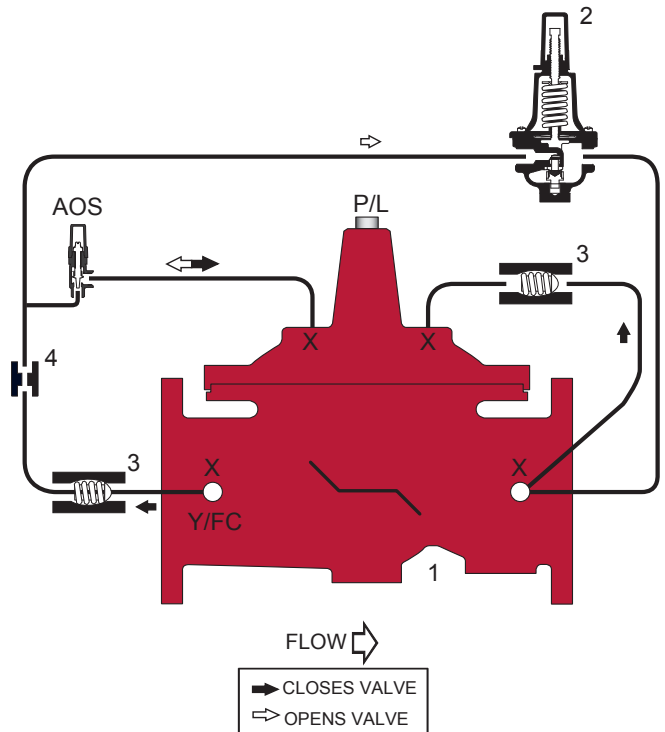

\*The wetted surface of this product contacted by consumable water contains less than 0.25% of lead by weight.

#### NOTICE

The information contained herein is not intended to replace the full product installation and safety information available or the experience of a trained product installer. You are required to thoroughly read all installation instructions and product safety information before beginning the installation of this product.

# M Series Basic Valves

## Pressure Reducing Control Valve with Hydraulic Check Feature

### Full Port Ductile Iron Single Chamber Basic Valve

This Watts Automatic Control Valve (ACV) is a full port, single chamber basic valve that incorporates a one-piece disc and diaphragm assembly. This assembly is the only moving part within the valve allowing it to open, close, or modulate as commanded by the pilot control system.

Watts ACV Main Valves are Lead Free. The Watts ACV piloting system contains Lead Free\* components, ensuring all of our configurations are Lead Free compliant.

Globe Pattern Single Chamber Basic Valve (M100)  
 Angle Pattern Single Chamber Basic Valve (M1100)

### Standard Materials

- Body and Cover:** Ductile Iron ASTM A536
- Coating:** NSF Listed Fusion Bonded Epoxy Lined and Coated
- Trim:** 316 Stainless Steel
- Elastomers:** Buna-N (standard)  
 EPDM (optional)  
 Viton™ (optional)
- Nut, Spring and Stem:** Stainless Steel
- Anti-Scale (Optional):** Xylan Coated Stem and Seat



Viton™ is a trademark of The Chemours Company FC, LLC

### Operating Pressure

- Threaded = 400psi (27.6 bar)
- 150# Flanged = 250psi (17.2 bar)
- 300# Flanged = 400psi (27.6 bar)
- Grooved End = 400psi (27.6 bar)

### Operating Temperature

- Buna-N: 160°F (71°C) Maximum
- EPDM: 300°F (140°C) Maximum
- Viton™: 250°F (121°C) Maximum
- Epoxy Coating\*\*: 225°F (107°C) Maximum

\*\* Valves can be provided without internal epoxy coating consult factory

### Basic Valve Body Options



Globe Flanged



Angle Flanged



Globe Grooved End



Angle Grooved End



Globe Threaded



Angle Threaded

# ACV Schematic - Series LFM115-3

## Flow Data

Valve Size - Inches		1/4	1/2	2	2 1/2	3	4	6	8	10	12	14	16
<b>Suggested</b>	Maximum Continuous Flow Rate Gpm (Water)	95	130	210	300	485	800	1850	3100	5000	7000	8500	11100
	Maximum Intermittent Flow Rate Gpm (Water)	119	161	265	390	590	1000	2300	4000	6250	8900	10800	14100
	Minimum Flow Rate Gpm (Water)	3	5	6	9	15	16	17	25	55	70	190	400
<b>Cv</b>	Cv Factor GPM (Globe)	26	26	48	75	112	188	387	764	1215	1734	2234	3131
	Cv Factor GPM (Angle)	26	27	57	91	125	207	571	889	1530	1945		

- Maximum continuous flow based on velocity of 20 ft. per second.
- Maximum intermittent flow based on velocity of 25 ft. per second.
- Minimum flow rates based on a 20-40 psi pressure drop.
- The C<sub>v</sub> Factor of a valve is the flow rate in US GPM at 60°F that will cause a 1psi drop in pressure.
- C<sub>v</sub> factor can be used in the following equations to determine Flow (Q) and Pressure Drop (ΔP):

$$Q \text{ (Flow)} = C_v \sqrt{\Delta P} \quad \Delta P \text{ (Pressure Drop)} = (Q/C_v)^2$$

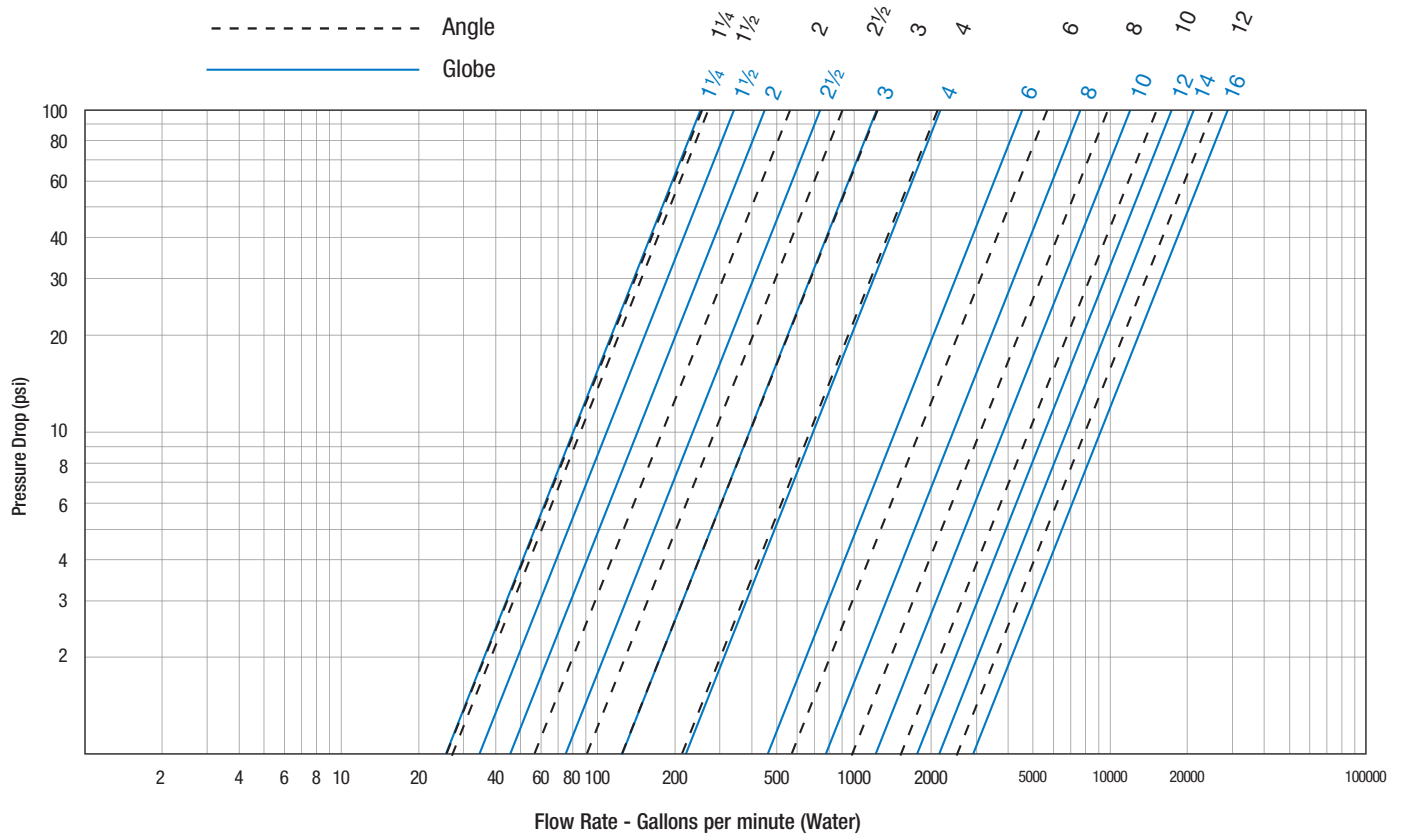

## Valve Cover Chamber Capacity

Valve Size - Inches	1/4	1/2	2	2 1/2	3	4	6	8	10	12	14	16
fl.oz.	4	4	4	10	16	22	70					
U.S. Gal								1 1/4	2 1/2	4	6 1/2	9 1/2

## Valve Travel

Valve Size - Inches	1/4	1/2	2	2 1/2	3	4	6	8	10	12	14	16
Travel - Inches	3/8	3/8	1/2	5/8	3/4	1	1 1/2	2	2 1/2	3	3 1/2	4

# ACV Schematic - Series LFM115-3

## M100 Basic Valve

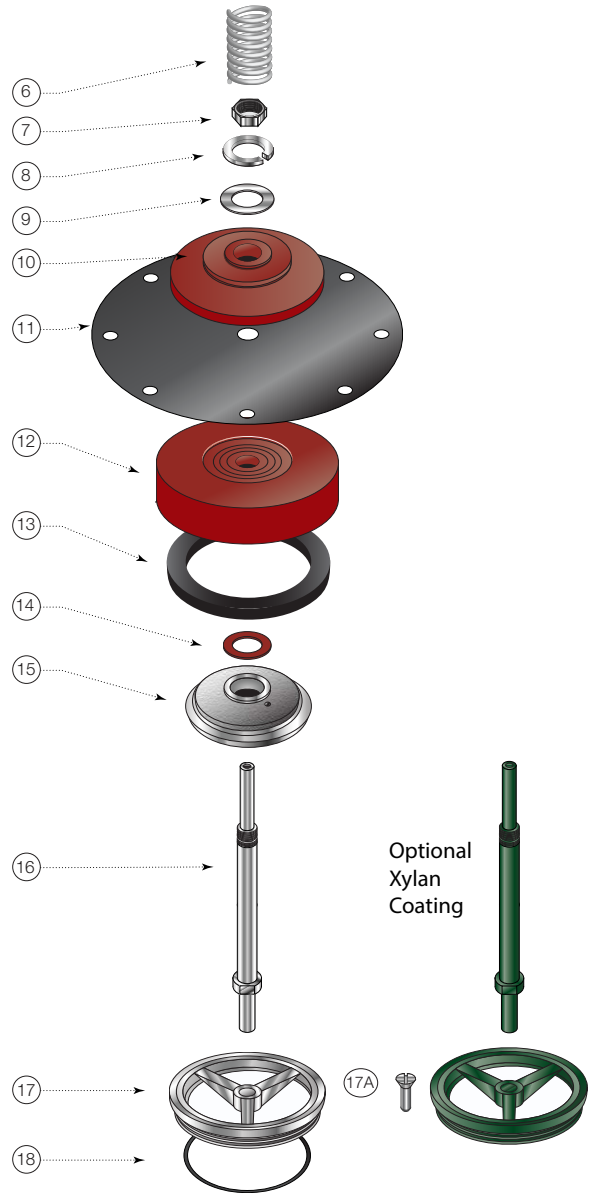

Item	Description	Material
1	Pipe Plug	Lead Free Brass
2	Cover	ASTM A536 65-45-12 Epoxy Coated Ductile Iron
3	Cover Bearing	ASTM A276 304 Stainless Steel
4	Stud with Cover Nut and Washer	ASTM A570 Gr.33 Zinc Plated Steel
5	Body	ASTM A536 65-45-12 Epoxy Coated Ductile Iron
6	Spring	ASTM A276 302 Stainless Steel
7	Stem Nut	ASTM A276 304 Stainless Steel
8	Lock Washer	ASTM A276 304 Stainless Steel
9	Stem Washer	ASTM A276 304 Stainless Steel
10	Diaphragm Washer	ASTM A536 65-45-12 Epoxy Coated Ductile Iron
11	Diaphragm*	Buna-N (Nitrile)
12	Disc Retainer	ASTM A536 65-45-12 Epoxy Coated Ductile Iron
13	Seat Disc*	Buna-N (Nitrile)
14	Spacer Washer* x5	NY300 Fiber*
15	Disc Guide	ASTM A743 CF8M (316) Stainless Steel
16	Shaft	ASTM A276 304 Stainless Steel
17	Seat Ring**	ASTM A743 CF8M (316) Stainless Steel
17A	Seat Screw** (8" and Larger)	ASTM A276 304 Stainless Steel
18	Seat Gasket*	Buna-N (Nitrile)

\* Contained in Main Valve Repair Kit  
 \*\*Note: 6 inch and Smaller Valves, Seat Ring is threaded

### NOTICE

Installation: If unit is installed in any orientation other than horizontal (cover up) OR extreme space constraints exist, consult customer service prior to or at the time of order.

# ACV Schematic - Series LFM115-3

## Dimensions

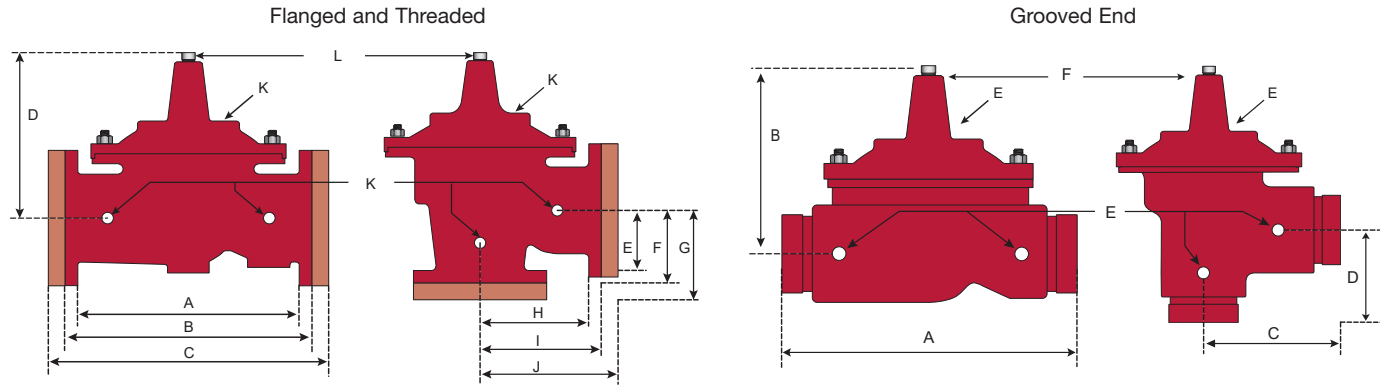

### Flanged and Threaded Dimensions

Valve Size	Globe Thread		Globe 150#		Globe 300#		Cover To Center		Angle Thread		Angle 150#		Angle 300#		Angle Thread		Angle 150#		Angle 300#		Port Size NPT	Port Size NPT	Shipping Weights*	
	A	B	C	D	E	F	G	H	I	J	K	L												
in.	in.	mm	in.	mm	in.	mm	in.	mm	in.	mm	in.	mm	in.	mm	in.	mm	in.	mm	in.	mm	in.	in.	lbs.	kgs.
1¼	7¼	184					5½	140													¾	¼	20	9
1½	7¼	184	8½	216			5½	140	¾	83					1⅞	48					¾	¼	25	11
2	9⅞	238	9⅞	238	10	254	6¾	171	4¾	120	4¾	121	5	127	3¼	83	3¼	83	3½	89	¾	½	40	18
2½	11	279	11	279	11½	295	7½	191	5½	140	5½	140	5⅞	149	4	102	4	102	4⅞	110	½	½	65	29
3	12½	318	12	305	13¼	337	8¼	210	6¼	159	6	152	6⅞	162	4½	114	4	102	4⅞	111	½	½	95	43
4			15	381	15⅞	397	10⅞	270			7½	191	7⅞	200			5	127	5⅞	135	¾	¾	190	86
6			20	508	21	533	13	330			10	254	10½	267			6	152	6½	165	¾	¾	320	145
8			25⅜	645	26⅜	670	16	406			12¾	324	13¼	337			8	203	8½	216	1	1	650	295
10			29¾	756	31⅞	791	17	430			14⅞	378	15⅞	395			8⅞	219	9⅞	237	1	1	940	426
12			34	864	35½	902	20⅞	530			17	432	17¾	451			13¾	349	14½	368	1	1¼	1500	680
14			39	991	40½	1029	24¼	616													1	1½	1675	760
16			41⅜	1051	43½	1105	25¼	640													1	2	3100	1406

### Grooved End Dimensions

Valve Size	Globe Grooved		Cover To Center		Angle Grooved		Angle Grooved		Port Size (npt)	Port Size (npt)	Shipping Weights*	
	A	B	C	D	E	F					lbs.	kgs.
in.	in.	mm	in.	mm	in.	mm	in.	mm	in.	in.		
1¼	8½	216	5½	140	4¼	108	¾	83	¾	¼	25	11
1½	8½	216	5½	140	4¼	108	¾	83	¾	¼	25	11
2	9	229	6½	165	4¾	121	¾	83	¾	½	40	18
2½	11	279	7½	191	5½	140	4	102	½	½	65	29
3	12½	318	8¼	210	6	152	4¼	108	½	½	95	43
4	15	381	10⅞	270	7½	191	5	127	¾	¾	190	86
6	20	508	13⅜	340					¾	¾	320	145
8	25⅜	645	16	406					1	1	650	295

**LEAD FREE\***

# Model LFCP15

## Pressure Reducing Pilot

Size: 3/8" NPT

The Model LFCP-15 is a direct acting, diaphragm actuated Pilot that automatically reduces a higher upstream (inlet) pressure to a constant downstream (outlet) pressure. It is normally held open by the force of the adjustable spring setting above the diaphragm.

The Pilot modulates towards a closed position when outlet pressure exceeds the spring setpoint, lowering the delivery pressure. It modulates towards an open position when the outlet pressure falls below the spring setpoint, increasing the delivery pressure.

When a Model LFCP-15 is installed in the piping circuit of an Automatic Control Valve, its throttling action causes the Main Valve to throttle open or closed accordingly. Turning the adjustment screw clockwise raises the control setpoint, increasing main valve outlet pressure. Turning the adjustment screw counterclockwise lowers the control setpoint, decreasing Main Valve outlet pressure.

The Model LFCP-15 is equipped with one 3/8" NPT inlet and two outlet ports for ease of installation. The unused outlet port may be plugged or used as a pressure gauge connection.



Model LFCP15

### Specifications

- Body Material:** Lead Free Copper Silicon Alloy  
CF8M (316) Stainless Steel (optional)
- Seat:** 316 Stainless Steel
- Elastomers:** Buna-N (standard)  
Viton™ (optional)  
EPDM (optional)
- Inlet Pressure Rating:** 400psi (27.6 bar) maximum
- Adjustment Range:** 30-300psi (2.1 - 20.7 bar) (standard)  
2-30psi (0.15-2 bar) (optional)

Viton™ is a trademark of The Chemours Company FC, LLC

\*The wetted surface of this product contacted by consumable water contains less than 0.25% of lead by weight.

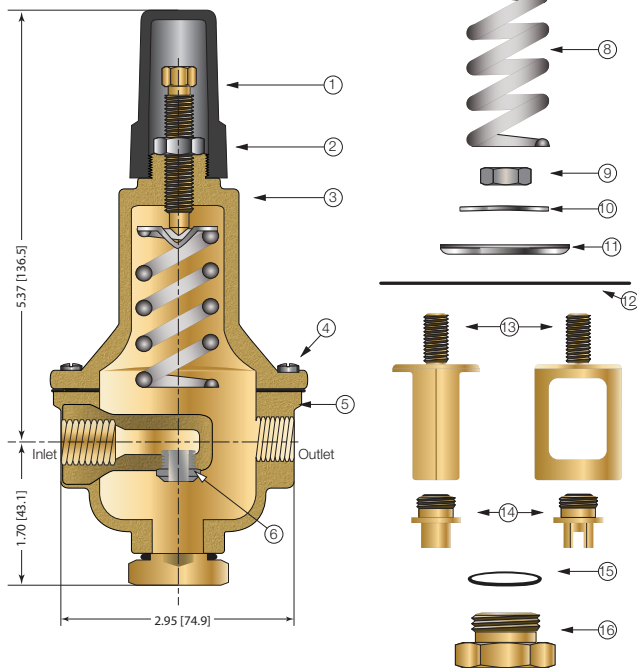

Item	Description
1	Adjusting Screw
2	Nut
3	Spring Housing
4	Cap Screw
5	Body
6	Seat
7	Spring Guide
8	Spring
9	Nut
10	Belleville Washer
11	Diaphragm Washer
12	Diaphragm*
13	Yoke
14	Disc and Retainer Assembly*
15	O-Ring*
16	Bottom Cap

\*Included in Repair Kit



**LEAD FREE\***

## Model CK

### Check Valve

Size: 1/4" – 1" NPT

Model CK Check Valves are pilot line check valves. In typical applications these low cracking pressure in-line checks provide a hydraulic check feature to a pilot system. When the main valve outlet pressure exceeds inlet pressure, fluid is directed from the outlet to the main valve cover. This causes the main valve to close until inlet pressure is again greater than outlet.



Model LFCV

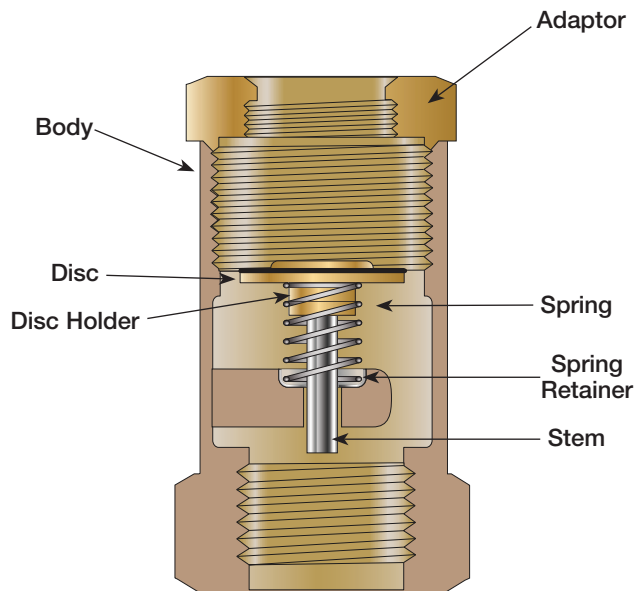

### Specifications

Standard Material: Brass Housing and Body  
Stainless Steel Indicating Rod

Optional Material: Stainless Steel Housing and Body Disc  
Viton™ (1/4" – 1/2")  
PTFE (1")

Pressure Rating: 400psi (27.6 bar)

Viton™ is a trademark of The Chemours Company FC, LLC

\*The wetted surface of this product contacted by consumable water contains less than 0.25% of lead by weight.



**LEAD FREE\***

# Model BV

## Ball Valve

Size: 1/4" – 1" NPT

Model BV Ball Valves are used in pilot lines to provide a positive shutoff in any override or maintenance situation for simple trouble shooting. This 2-piece, full port valve features: bottom loaded stems, PTFE seats and packing.

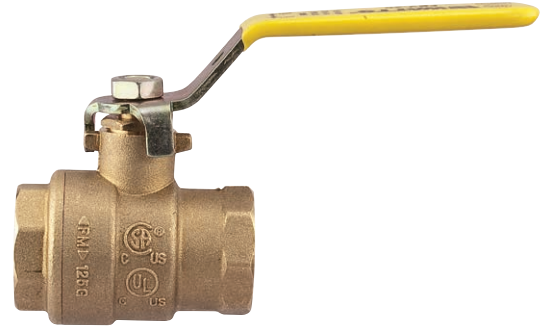

Lead Free Ball Valve

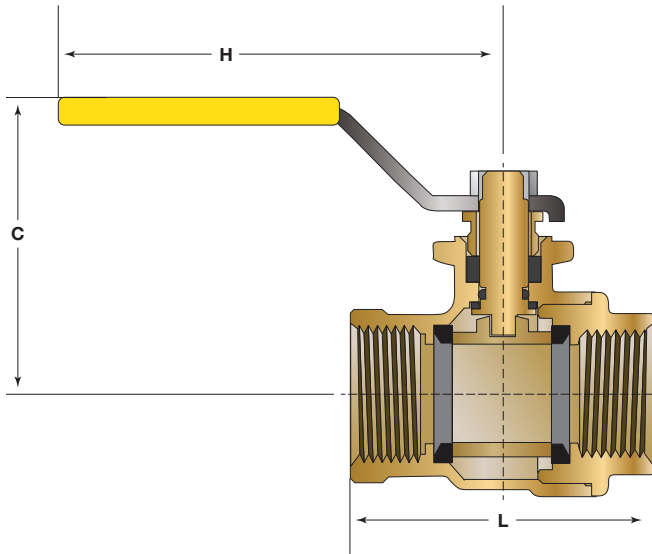

### Specifications

- Standard Material: Copper Silicon Alloy Body and Adaptor  
Chrome Plated Ball
- Optional Material: Stainless Steel Housing, Body and Adaptor  
Stainless Steel Ball
- Pressure Rating: 600psi (41 bar) Non Shock
- Temp Rating: -40°F - 400°F

\*The wetted surface of this product contacted by consumable water contains less than 0.25% of lead by weight.

Size	Dimensions						Weight	
	C		H		L			
in.	in.	mm	in.	mm	in.	mm	lbs.	kg.
1/4	1 13/16	46	3 7/16	87	1 3/4	45	0.4	0.2
3/8	1 13/16	46	3 7/16	87	1 3/4	45	0.4	0.2
1/2	1 13/16	46	3 7/16	87	1 15/16	50	0.4	0.2
3/4	2 1/4	57	4	101	2 5/16	59	0.8	0.3

**LEAD FREE\***

## Model LF60

### Flo-Clean Strainer

Size: 1/4" – 3/4" NPT

Model LF60 Flo-Clean Strainers are used to filter the fluid passing through the pilot circuit, and provide protection to pilot circuit speed controls and pilots. It is installed in the inlet body port of the Main Valve, exposing the strainer element to main line flow. The currents and flow across the screen create a self-scouring effect, cleaning the filter element.

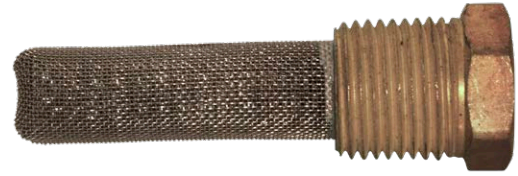

Model LF60

Valve inlet with Filter installed

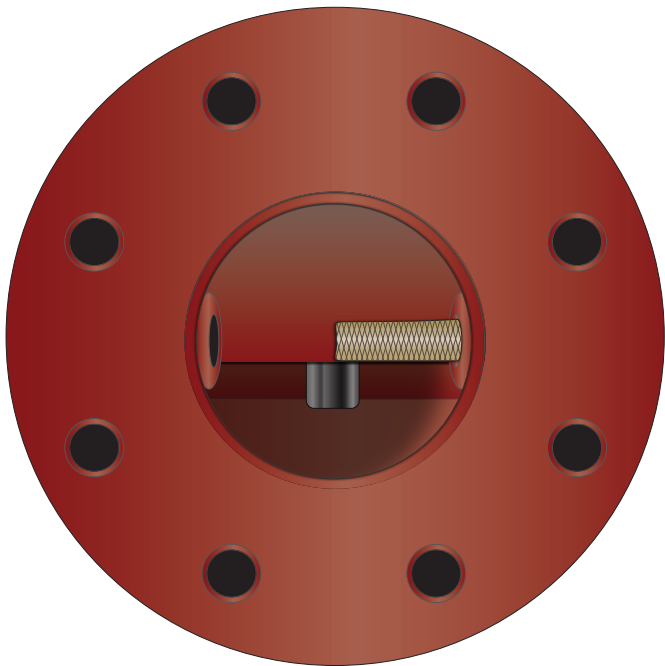

### Specifications

Body Material:	Lead Free Brass (standard) Stainless Steel (optional)
Pressure Rating:	400psi (27.6 bar)
Filter Element:	Monel
Screen Mesh:	40 Mesh (standard)

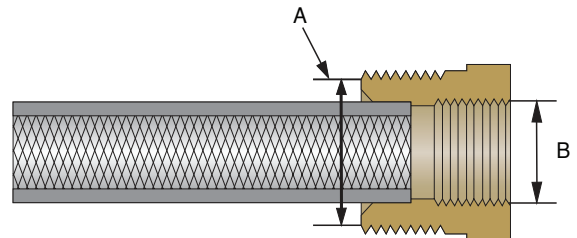

A	B
Male Pipe Thread	Female Pipe Thread
in.	in.
1/4	1/8
3/8	1/4
1/2	3/8

\*The wetted surface of this product contacted by consumable water contains less than 0.25% of lead by weight.

**LEAD FREE\***

## Model LF60-1

### Y-Pattern Strainer

Size: 1/4" – 3/4" NPT

Model LF60-1 Y-Pattern Strainers are used to filter the fluid passing through the pilot circuit, and provide protection to pilot circuit speed controls and pilots. The filter element can be accessed for cleaning by removing the clean-out cap, or may be cleaned by installing an optional "blow-down" ball valve.



Model LF60-1

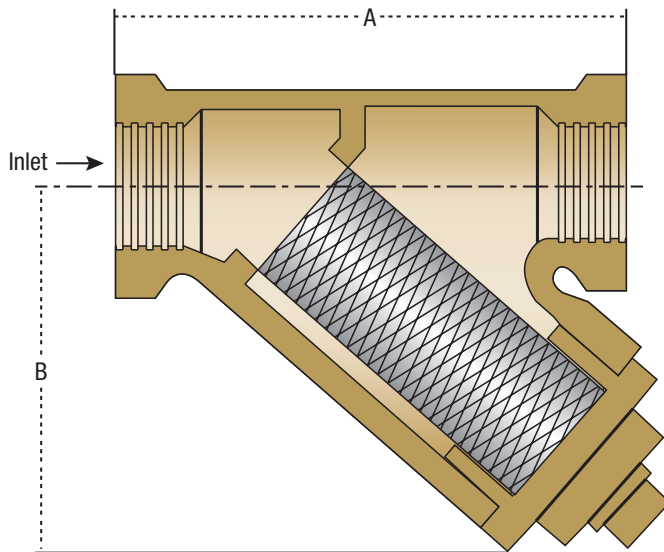

### Specifications

- Body Material:** Lead Free Copper Silicon Alloy  
CF8M (316) Stainless Steel (optional)
- Retainer Cap:** Lead Free Copper Silicon Alloy
- Cap Gasket:** EPDM
- Pressure Rating:** 400psi (27.6 bar)
- Filter Element:** 304 Stainless Steel
- Mesh Options:** 60 Mesh (standard)  
100 Mesh (optional)

### Dimensions

SIZE	DIMENSIONS				WEIGHT	
	A		B		lbs.	kgs.
in.	in	mm	in	mm		
1/4	2 1/16	68	1 1/16	43	1.7	0.77
3/8	2 1/16	68	1 1/16	43	1.7	0.77
1/2	3	76	2	51	1.7	0.77
3/4	3 5/16	84	2 5/16	59	1.7	0.77

\*The wetted surface of this product contacted by consumable water contains less than 0.25% of lead by weight.

**LEAD FREE\***

## Model LFFC

### Flow Control

Size: 1/2" NPT

A Flow Control is an adjustable device used for tuning valve performance. It can be installed to either control the opening or closing the speed of the automatic control main valve. When the flow is in the direction of the needle the flow control is an adjustable restriction. In the free flow direction the seat moves out of the flow path to all unrestricted flow.

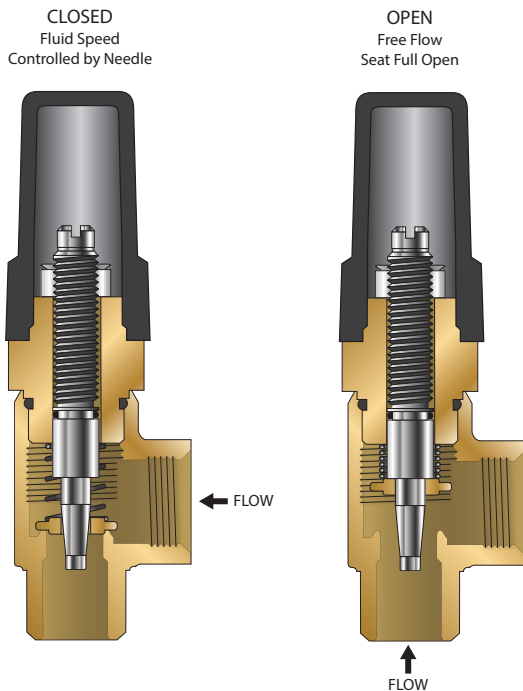

Model LFFC

### Specifications

Size:	1/2" NPT
Body Material:	Lead Free Brass Stainless Steel (optional)
Seat:	Lead Free Brass
Needle:	Stainless Steel (304)
Elastomers:	Buna-N (standard)

\*The wetted surface of this product contacted by consumable water contains less than 0.25% of lead by weight.

**LEAD FREE\***

# Model 50

## Position Indicator

When specified as an option on a Control Valve, the Model 50 Position Indicator is installed in the topmost cover port of the Main Valve and allows for visual indication of valve position. The Model 50 is also very useful during valve start-up and troubleshooting procedures.

A stainless steel indicating rod threads into the tapped portion of the Main Valve stem and moves inside of a cylindrical Pyrex sight tube. The indicating rod travels up and down, following Main Valve stem movement. The housing protects the sight tube and indicating rod, and allows visibility on two sides. The screw driver operated test cock installed on the top of the Model 50 housing provides a controlled method of removal of air from the cover chamber during start-up or troubleshooting of the Main Valve.



Model LF50

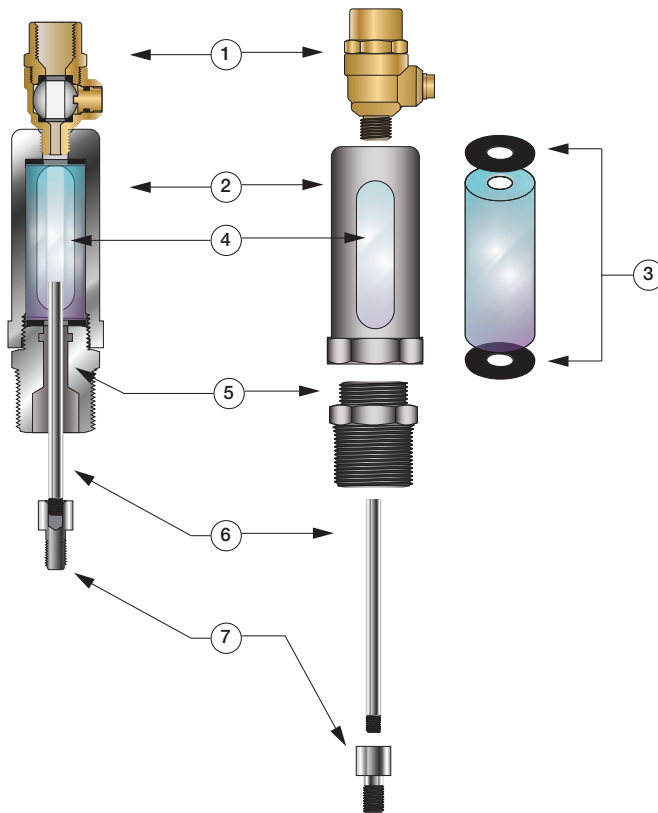

Item	Description
1	Test Cock
2	Housing
3	Gasket
4	Pyrex Sight Tube
5	Body
6	Indicating Rod
7	Stem Adaptor (8" or Larger)

### Specifications

- Standard Material:** Stainless Steel Housing and Body  
Stainless Steel Indicating Rod  
Lead Free Test Cock  
Pyrex Sight Tube
- Optional Material:** Stainless Steel Test Cock
- Pressure Rating:** 400psi (27.6 bar)

\*The wetted surface of this product contacted by consumable water contains less than 0.25% of lead by weight.

### Dimensions

Valve Size (in)	Dimension (in)
1 ¼ - 1 ½	7 ⅜
2	4 ⅞
2 ½	4 ⅞
3	4 ⅞
4	5
6	5
8	5 ⅞
10	5 ⅞
12	7 ¼
14	7 ¼
16	7 ¼
18*	7 ¼
20*	7 ¼
24*	7 ¼

\*Reduced Port

**LEAD FREE\***

## Model 51 Single Limit Switch

The Model 51 Single Limit Switch provides visual indication of valve position, as well as remote electrical indication of "valve open" or "valve closed". The single pole double throw Micro-Switch can be connected to open or close an electrical circuit when the valve opens or closes.

The adjustable collar is normally set to contact the trip arm when the main valve is closed. The collar can be positioned on the stem by loosening the set-screw to actuate the switch at the desired point of valve travel.

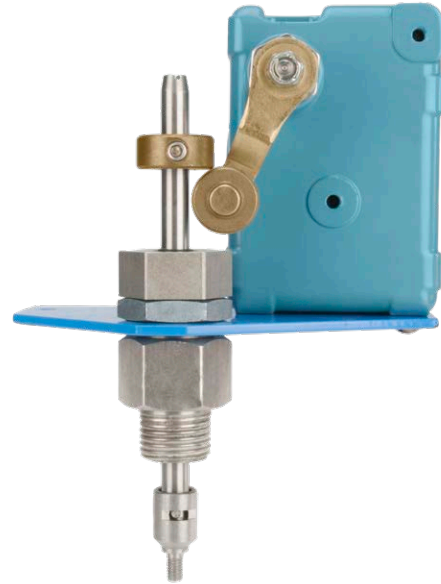

Model LF51

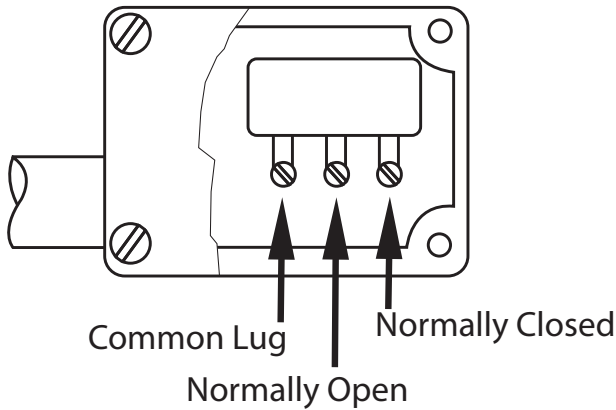

Single Pole Double Throw Switch

### Specifications

Body Material: Stainless Steel

Elastomers: Buna-N (standard)  
EPDM (optional)  
Viton™ (optional)

Enclosure: NEMA 1, 3, 4 and 13 General Purpose (standard)  
NEMA 1,7 and 9 Explosion Proof (optional)

Electrical: Form C SPDT Switch  
15 amp. 125, 250 or 480 VAC  
½ amp. 125 VDC  
¼ amp. 250 VDC  
½" Conduit Connection

Viton™ is a trademark of The Chemours Company FC, LLC

\*The wetted surface of this product contacted by consumable water contains less than 0.25% of lead by weight.

### Parts List

Item	Description
1	Limit Switch
2	Bracket
3	Stem
4	Trip collar
5	Set Screw
6	Cap
7	Wiper Ring*
8	O-Ring*
9	Guide
10	O-Ring*
11	Polypak*
12	Locknut
13	Body
14	Pin
15	Coupling

\*Included in Repair Kit

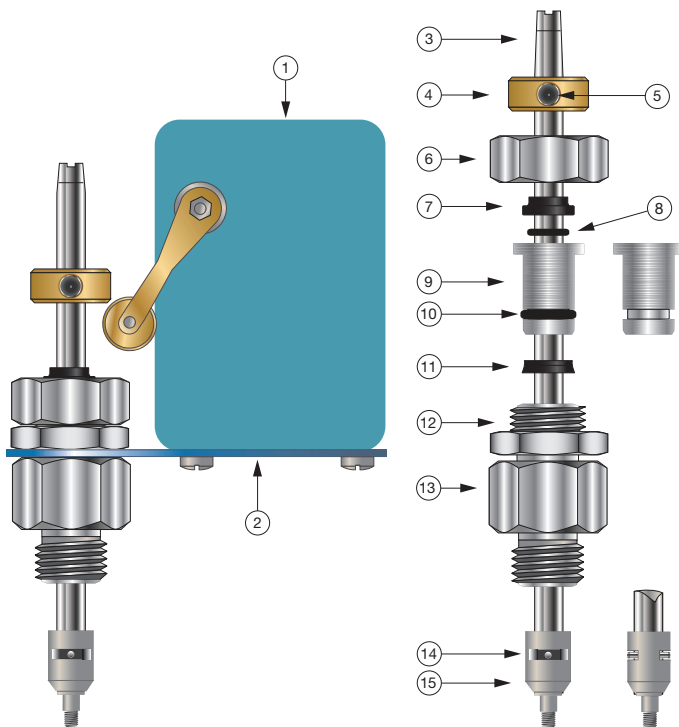

## Installation

Start-up of an automatic control valve requires that proper procedures be followed. Time must be allowed for the valve to react to adjustments and the system to stabilize. The objective is to bring the valve into service in a controlled manner to protect the system from damaging over-pressure.

1. Prior to installation, flush line to remove debris.
2. Install valve so the flow arrow matches flow through the line, and gauges to monitor valve inlet and outlet pressures. A Position Indicator can be installed to provide visual indication of valve position and operation without disassembly.
3. Install isolation valves upstream and downstream of the main valve.
4. Open the isolation ball valves in the control tubing if so equipped. Failure to open these will prevent the valve from functioning properly.

**Note:** If using butterfly valves, ensure valve disc does not contact the main valve.

5. Provide adequate clearance for valve servicing and maintenance. Refer to valve servicing dimensions on next page.
6. Avoid installing valves 6" and larger in the vertical position (main valve stem horizontal). Automatic Control Valves (ACVs) are designed for horizontal in-line installation, with the cover facing up (main valve stem vertical). Slow operation or premature stem and guide wear may occur if valve is not installed according to factory recommendations. Consult factory for detailed engineering review prior to ordering if valve is to be installed other than horizontally in-line.
7. If valve is equipped with a pilot control system, extra precautions should be made during installation to protect the piping circuit from damage. Only remove the pilot control system from the valve if necessary. Tubing and fittings should be kept clean and replaced exactly as removed. Consult appropriate hydraulic schematic to ensure proper re-assembly.
8. After installation, vent entrapped air from valve cover and pilot system by following instructions in the **Setting the Pressure Reducing Control** section on the following page.

## Valve Servicing Dimensions

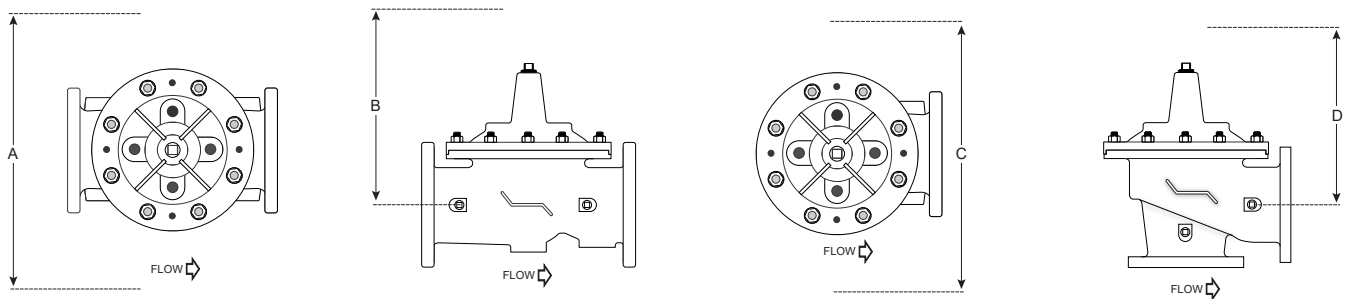

The following tables detail the recommended minimum valve servicing dimensions.

### Globe

Size (in)	1¼	1½	2	2½	3	4	6	8	10	12	14	16	20	24
A (in)	16	16	20	22	22	24	32	34	38	44	48	52	56	56
B (in)	10	10	12	14	14	16	24	26	28	30	34	40	48	48

### Angle

Size (in)	1¼	1½	2	2½	3	4	6	8	10	12	14	16
C (in)	16	16	20	22	22	24	32	34	38	44	48	52
D (in)	10	10	12	14	14	16	24	26	28	30	34	40



## Setting the Pressure Reducing Control

Note: Starting up the system will require bleeding air and draining water from the valve. Take proper precautions to protect your space from water damage.

Note: Start with the upstream and downstream isolation valves in your system closed, Labeled 1 and 2 in Figure 1 respectively.

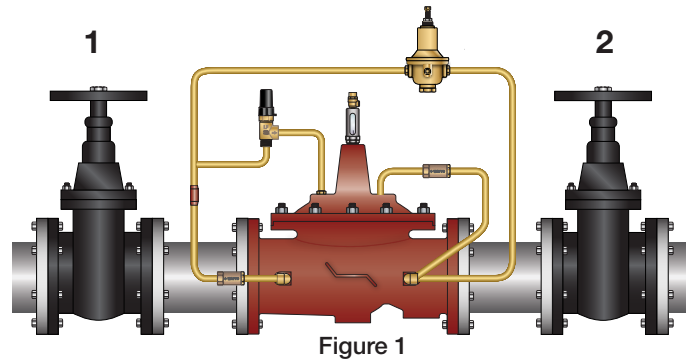

### STEP 1

Pre-set pilots as noted:

**Pressure Reducing** – Adjust OUT, counterclockwise, backing pressure off the spring, preventing possible over-pressuring of the system (See Images 1 and 2).

**Opening and Closing Speed** – Turn the adjustment screws on the Closing Speed and Opening Speed Controls, if the main valve is so equipped, OUT, counterclockwise, 1½ to 2½ turns from full closed position (See Images 3 and 4).

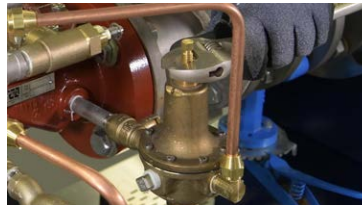

Image 1

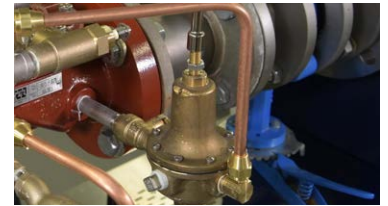

Image 2



Image 3



Image 4

### STEP 2

Loosen a tube fitting or cover plug at the main valve to allow air to vent during start-up (See Image 5 and 6).



Image 5



Image 6

## STEP 3

Pressure the line, opening the upstream isolation valve slowly (Labeled #1 in Figure 2). Air is vented through the loosened fitting. Tighten the fitting when liquid begins to vent.

## STEP 4

Slowly open downstream isolation valve to establish flow through the system (Labeled #2 in Figure 2).

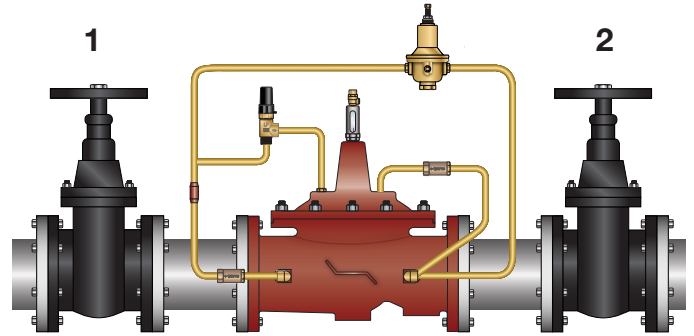

Figure 2

## STEP 5

Fine-tune the Pressure Reducing Control adjustment to the pressure set point by turning the adjustment screw IN, clockwise to increase or OUT, counterclockwise to decrease downstream pressure (See Image 7).



Image 7

## STEP 6

Opening Speed Flow Control Adjustment: The Opening speed flow control allows free flow into the cover and restricted flow out of the cover of the main valve. If recovery of pressure is slow upon increased downstream demand, turn the adjustment screw OUT, counterclockwise, increasing the rate of opening. If recovery of downstream pressure is too quick, as indicated in a rapid increase in pressure, possibly higher than the desired set-point, turn the adjustment screw IN, clockwise, decreasing the rate of opening (See Image 8).



Image 8

## Step 7

Closing Speed Needle Valve Adjustment: The closing speed needle valve regulates fluid pressure into the main valve cover chamber, controlling the valve closing speed. If the downstream pressure fluctuates slightly above the desired set point, turn the adjustment screw OUT, counterclockwise, increasing the rate of closing.

*Note: Check feature automatically functions with no adjustment required.*

## Automatic Control Valve Maintenance Schedule

To ensure peak performance and longevity of your automatic control valve, Watts/Ames recommends following the below standard maintenance schedule.

### • Monthly Maintenance

- Visual inspection of valve(s) for leaks
- Inspect for proper operation(s); exercise valve.

### • Quarterly Maintenance

- Conduct monthly inspection.
- Validate/Re-establish necessary setpoints of controls/pilots.

### • Annual Maintenance

- Conduct monthly & quarterly inspections.
- Inspect & clean all strainers.
- Inspect valve coating, touch up as required.

### • 3-5 Year Maintenance

- Conduct monthly, quarterly, & annual maintenance.
- Inspect & replace valve elastomers (diaphragm, O-rings, valve/pilot seats)
- Re-establish necessary set points of controls/pilots.

## Troubleshooting Guide

### ⚠ WARNING

**Warning:** The valve cannot be serviced under pressure. Upstream and downstream Isolation Valves must be installed to protect system piping. Accurate diagnosis and troubleshooting requires the valve to open fully, and may subject downstream piping and equipment to high pressure and/or flow rates. The downstream Isolation Valve should be kept closed while diagnosing the valve.

**Extreme caution should be used while performing the troubleshooting techniques listed below.**

Recommended tools for diagnosis: (3) PRESSURE GAUGES, installed to monitor the inlet pressure, outlet pressure, and cover chamber pressure. If included, a POSITION INDICATOR should be installed to visually assess the position of the disc & diaphragm assembly.

### Test 1: Diaphragm Seal Test

1. Close upstream & downstream isolation valves. Close pilot isolation valves or remove pilot control tubing to isolate valve cover from incoming fluid & pressure. Remove uppermost cover plug, test cock, or limit switch.
2. With the valve cover chamber vented to atmosphere, partially open the upstream isolation valve, allowing incoming pressure to lift the disc & diaphragm assembly. A volume of water will be displaced from the cover chamber as the valve opens; consult valve specification sheets for approximate cover capacity. A continuous flow of water from the open port indicates a damaged diaphragm or loose disc & diaphragm assembly. Disassemble valve and replace diaphragm or tighten disc & diaphragm assembly.

### Test 2: Seat Seal Test

1. Close downstream isolation valve and install pressure gauges on an open inlet and outlet port of main valve.
2. Open upstream isolation valve to allow pressure on to the valve cover. Allow valve to fully close.
3. Monitor downstream pressure gauge; reading should hold steady below incoming pressure. If pressure on downstream side rises to match upstream pressure, leakage is occurring through the seat of the main valve. Disassemble valve, inspect and repair/replace any required parts.
  - a. If gauge pressure rises to match outlet pressure (downstream of closed isolation valve) yet remains below inlet pressure, the isolation valve may be leaking as opposed to main valve seat.

### Test 3: Freedom of Movement/Valve Travel Test

1. Close upstream and downstream isolation valves. Install valve position indicator.
2. Partially open upstream isolation valve and allow cover to fill with fluid & pressure, closing the valve fully. Mark the position indicator's full closed position.
3. Isolate cover chamber from receiving fluid and pressure by closing isolation valves or removing control tubing.
4. Carefully vent cover chamber to atmosphere by opening test cock or removing a cover plug. Observe the valve position indicator as the valve travels to the full-open position. The disc & diaphragm assembly should move freely from fully closed to fully open position without binding or "grabbing" at any point during its movement.
  - a. The disc & diaphragm assembly may momentarily "hesitate" while travelling from fully closed to fully open position – this is a normal characteristic of diaphragm operated control valves, and does not indicate mechanical binding or improper valve operation.
  - b. A continuous discharge of water from the cover chamber after venting to atmosphere indicates leakage past the diaphragm.
5. If necessary, disassemble valve and inspect/repair disc & diaphragm assembly.

## Troubleshooting Guide

<b>Issue</b>	<b>Possible Cause</b>	<b>Corrective Action</b>	<b>Notes</b>
<b>Main Valve will not open</b>	Closed isolation valves in pilot system.	Check isolation valves, ensure open.	
	Insufficient supply pressure.	Check upstream pressure.	Depending on water source, supply pressure may not be controlled by valve operator.
	Main valve stem assembly corroded/damaged.	Inspect stem assembly, clean/replace if necessary.	
	Blockage in pilot system.	Inspect & clean any installed pilot system strainers, check orifice/speed controls for blockages.	
	Missing fixed orifice assembly.	Verify installation of orifice; replace if required/missing.	Pilot valve inlet isolation valve can be used as a makeshift orifice assembly by partially opening from full closed position.
	Improperly configured opening speed control (if equipped).	Adjust opening speed control to verify functionality, adjust as required.	Standard setting for opening speed control is 1½ - 2½ turns open from full closed position. Can be adjusted in field.
<b>Main Valve will not close</b>	Closed isolation valves in pilot system	Check isolation valves, ensure open.	
	Diaphragm is damaged	Conduct diaphragm seal test, repair and replace if necessary.	
	Main valve stem assembly corroded/damaged.	Inspect stem assembly, clean/replace if necessary.	
	Blockage in main valve.	Perform freedom of movement test; if valve does not close, disassemble and remove blockage.	
	Worn/damaged valve seat.	Perform seat sealing check; disassemble and inspect/repair seat if required.	

## Valve Disassembly Instructions

Before undertaking valve disassembly, it is recommended to gather the following tools to aid you during the process:

- Small & large adjustable wrenches
- Screwdriver set
- Machinist fine metal file
- Fine wire brush
- Bench vise
- Basic valve IO&M manual
- Hammer & dull cold chisel
- Heavy-duty ratchet & socket set
- Hexagonal wrench set
- 320 grit/fine Emery cloth
- Appropriate technical bulletins for valve start-up procedures.

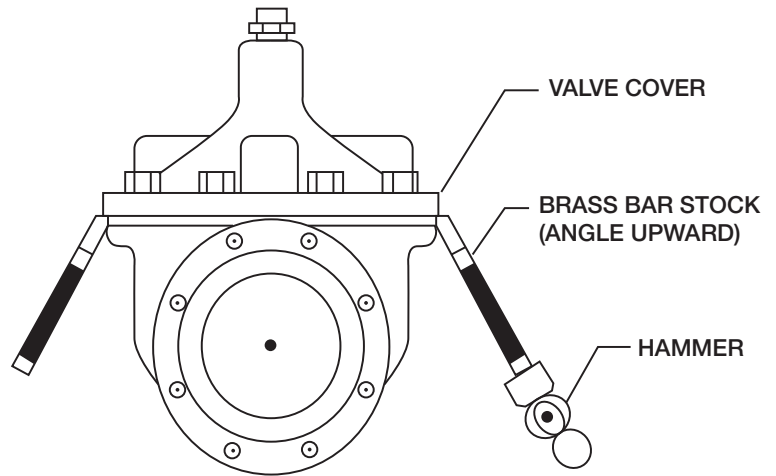

1. Isolate the valve from line pressure and depressurize it to ensure safe working conditions. Disconnect any electrical connections if so equipped.
2. Carefully remove Position Indicator or Limit Switches if equipped. Remove all tubing, fittings, and Control Pilots necessary to easily access and remove the cover. Remove cover nuts and washers.
3. Remove the cover. If cover is not free to be removed, loosen it by tapping upward along its outside edge with a dull cold chisel, pictured above.
  - a. Large valves may require the installation of lifting “eye” bolts in order to facilitate cover removal; installation ports are provided on the cover for this purpose.
4. Remove the Disc and Diaphragm Assembly from the valve body by lifting straight up.
  - a. Large diameter valves may require a lifting “eye” bolt to be installed in the valve stem accessory threads located on the very top of the valve stem.
5. Before removing Stem Nut, examine stem threads for mineral build-up. Remove deposits with a fine wire brush. Extreme care should be taken not to damage the finish on stem guiding surfaces when disassembling. Avoid applying pipe wrenches to top or bottom stem guide surfaces.
6. After removing the Stem Nut, the remainder of the Disc & Diaphragm Assembly should disassemble easily. Polish stem guide surfaces with fine emery cloth to remove any mineral deposits and inspect for excessive wear. Remove any mineral build-up from other components with wire brush or by using a Mineral Dissolving Solution. Inspect parts for wear and replace if necessary.
7. Inspect valve seat. If seat is not damaged, removal is not necessary. Valve seats 6" and smaller are threaded into the body of the valve and require a seat removal tool (Figure 3) (Table 1 details the tool dimensions for seat removal). Valve seats 8" and larger are held in the valve body with stainless steel cap screws. Remove seat retaining screws and lift seat straight up (Figure 4).

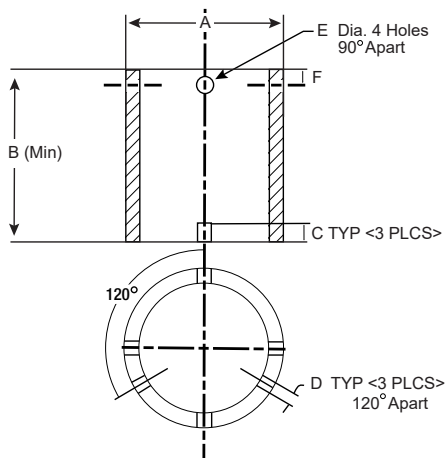

**Figure 3**

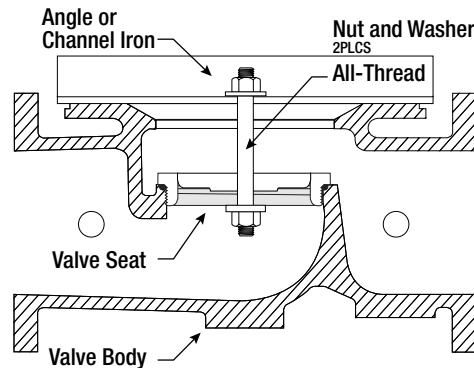

**Figure 4**

## Installation, Operation and Maintenance - Series LFM115-3

**Table 1: Seat Removal Tool Dimension**

Size	A	B	C	D	E (Dia.)	F
<i>in</i>	<i>Pipe Size (in)</i>	<i>Min. Length (in)</i>	<i>in</i>	<i>in</i>	<i>in</i>	<i>in</i>
1¼	1	3.12	0.38	0.25	0.44	0.55
1½	1	3.12	0.38	0.25	0.44	0.50
2	1¼	3.38	0.38	0.25	0.44	0.50
2½	2	4.0	0.38	0.38	0.56	0.62
3	2½	4.5	0.50	0.38	0.56	0.62
4	3	5.0	0.50	0.44	0.56	0.62
6	5	6.50	0.62	0.44	0.56	0.62

\*Schedule 40 steel pipe

- Replace Seat Disc, Diaphragm and Spacer Washers provided in Main Valve repair kit (refer to Table 2 or 3 for correct repair kit part number). Re-assemble in the reverse order of disassembly.

**Table 2: Full Port Valve (M100/M1100) Repair Kits**

Size (in)	1¼	1½	2	2½	3	4	6	8	10	12	14	16
P/N	0677-01	0677-01	0677-02	0677-03	0677-04	0677-05	0677-06	0677-07	0677-08	0677-09	0677-10	0677-11

**Table 3: Reduced Port Valve (M6100 / M61100) Repair Kits**

Size (in)	3	4	6	8	10	12	16	20 & 24
P/N	0677-02	0677-04	0677-05	0677-06	0677-07	0677-08	0677-09	0677-11

- Re-Install Disc and Diaphragm Assembly in the valve, taking care not to damage the lower guide area in the center of the valve seat.
- Re-install Cover Spring. Replace Valve Cover and tighten Cover Nuts in a crossing pattern to ensure even distribution. Test the Disc and Diaphragm Assembly for smooth travel by following the Freedom of Movement Test procedure in previous section.
- Test the integrity of the Seat Seal by following the Seat Seal Test procedure in previous section.
- Return valve to service by following instructions in the **Setting the Pressure Reducing Control** section matching the valve function.



**Limited Warranty:** Watts Regulator Co. (the "Company") warrants each product to be free from defects in material and workmanship under normal usage for a period of one year from the date of original shipment. In the event of such defects within the warranty period, the Company will, at its option, replace or recondition the product without charge.

**THE WARRANTY SET FORTH HEREIN IS GIVEN EXPRESSLY AND IS THE ONLY WARRANTY GIVEN BY THE COMPANY WITH RESPECT TO THE PRODUCT. THE COMPANY MAKES NO OTHER WARRANTIES, EXPRESS OR IMPLIED. THE COMPANY HEREBY SPECIFICALLY DISCLAIMS ALL OTHER WARRANTIES, EXPRESS OR IMPLIED, INCLUDING BUT NOT LIMITED TO THE IMPLIED WARRANTIES OF MERCHANTABILITY AND FITNESS FOR A PARTICULAR PURPOSE.**

The remedy described in the first paragraph of this warranty shall constitute the sole and exclusive remedy for breach of warranty, and the Company shall not be responsible for any incidental, special or consequential damages, including without limitation, lost profits or the cost of repairing or replacing other property which is damaged if this product does not work properly, other costs resulting from labor charges, delays, vandalism, negligence, fouling caused by foreign material, damage from adverse water conditions, chemical, or any other circumstances over which the Company has no control. This warranty shall be invalidated by any abuse, misuse, misapplication, improper installation or improper maintenance or alteration of the product.

Some States do not allow limitations on how long an implied warranty lasts, and some States do not allow the exclusion or limitation of incidental or consequential damages. Therefore the above limitations may not apply to you. This Limited Warranty gives you specific legal rights, and you may have other rights that vary from State to State. You should consult applicable state laws to determine your rights. **SO FAR AS IS CONSISTENT WITH APPLICABLE STATE LAW, ANY IMPLIED WARRANTIES THAT MAY NOT BE DISCLAIMED, INCLUDING THE IMPLIED WARRANTIES OF MERCHANTABILITY AND FITNESS FOR A PARTICULAR PURPOSE, ARE LIMITED IN DURATION TO ONE YEAR FROM THE DATE OF ORIGINAL SHIPMENT.**



---

**USA:** T: (978) 689-6066 • F: (978) 975-8350 • Watts.com  
**Canada:** T: (888) 208-8927 • F: (905) 481-2316 • Watts.ca  
**Latin America:** T: (52) 55-4122-0138 • Watts.com