

USER'S MANUAL MANUAL DEL USUARIO

BASS1300.3

800 WATTS | 8" (203mm) LOW PROFILE AMPLIFIED SUBWOOFER
PLUS 250 WATTS x 2 AMPLIFIED SPEAKER OUTPUTS

800 WATTS | 8" (203mm) SUBWOOFER AMPLIFICADO
DE PERFIL BAJO

MÁS 250 WATTS x 2 SALIDAS DE ALTAVOZ



BOSS[®]
AUDIO SYSTEMS

Congratulations on your purchase of the Boss Audio BASS1300.3, amplified Under Seat Subwoofer.

It has been designed, engineered and manufactured to bring you the highest level of performance and quality, and will afford you years of listening pleasure.

Thank you for making a Boss Audio your choice for car audio entertainment!

BASS1300.3

8" Amplified Under Seat Subwoofer

High & Low Level Input

LED Status Indicator

Subwoofer Phase Control

Soft Remote Turn-On

Subwoofer Remote Control

Variable Bass Boost

Low Pass Filter

Subsonic Filter

High Pass Filter

MAX Power @ 2Ω: (250 W x 2) + (800 W x 1)

Thermal, Short, Overload and Fuse Protection

Dimension: 14.5" (L) x 9.5 (W)" x 3"(H)

Weight: 11.6 lbs.

Introduction

The BASS1300.3, introduces a low-profile active subwoofer, with an additional 2 channels of amplified full-range output.

Its low enough to easily fit under the seat of your car, this system offers you a quick and easy way to add a high-powered 2 Ch amplifier and subwoofer to your audio system.

BASS1300.3 contains a 2 Channel Full-Range Amplifier and an Amplified Subwoofer

Both high-level (speaker level) and low-level (RCA) inputs are present, making this a universal solution for use with any head unit or other input sources.

What is included?

When first unpacking your new amplified system, please check that the package contains all of the items below.

If something is missing, contact our Tech Dept.

Main Unit

BASS1300.3 Amplified System

Accessories

Subwoofer Remote Control w/ Cable

High-Level Input Harness

Speaker Output Harness

Mounting Hardware

Mounting Feet

Mounting Feet Screws w/ Washers M3x10mm (x8)

Mounting Screws (x4)

Front Panel Controls and Features

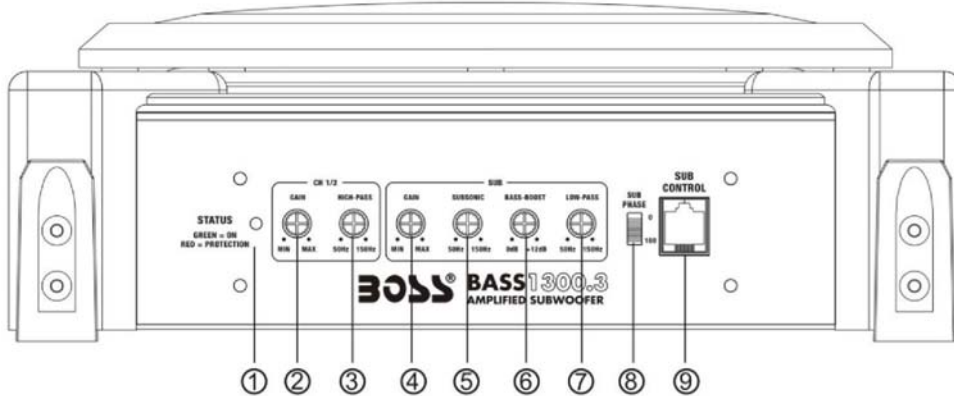

① LED STATUS INDICATOR

Green – On

Red – Protection

② CH 1/2 GAIN CONTROL

Ch 1/2 Gain control should be first set. The volume control on the head unit should be turned up to $\frac{3}{4}$ of max.

Slowly adjust the Gain to where distortion is barely audible and then back off a bit of the adjustment.

③ HIGH PASS FILTER

The HP filter can be adjusted from 50 Hz to 150 Hz @ 12dB/Oct.

④ SUBWOOFER GAIN CONTROL

Please note to use the same music track to set the Sub Gain as Ch 1/2.

The volume control on the head unit should be turned up to $\frac{3}{4}$ of max.

Slowly adjust the Gain to where distortion is barely audible and then back off a bit of the adjustment.

⑤ SUBWOOFER SUBSONIC FILTER

The subsonic filter can be adjusted 20-50Hz.

⑥ BASS BOOST

The bass boost is centered at 45 Hz. Adjusting this setting will boost 45 Hz up to 12 dB

⑦ LOW PASS FILTER

The LP filter is adjustable from 50 Hz to 150 Hz @ 12dB/Oct.

⑧ SUB PHASE

The Sub Phase can be used to adjust for bass response. Each vehicle will be different and should be set for your particular installation. If the bass response “disappears”, flipping the switch should fix and will properly align the phase with the rest of the system.

⑨ SUBWOOFER REMOTE CONTROL PORT

Attach the included remote control to control the level of the subwoofer independently. This should be installed in a convenient location where you can adjust the level of subwoofer easily.

Rear Panel Controls and Features

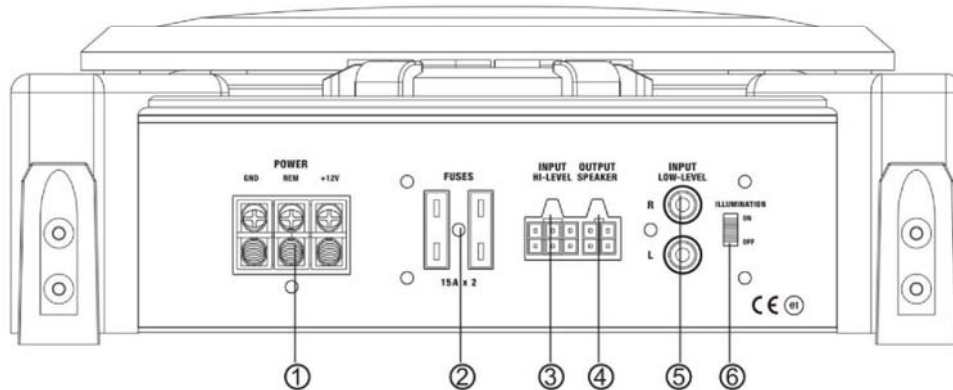

① POWER TERMINALS

Planet Audio recommends the use of high quality 8 gauge wiring. The ground should be kept under 3ft (36"). Always scrape away any paint for the ground connection. Ground point should be clean with the correct type of bolt to secure it.

The +12V wire should be fused (30 A) within 18" of the battery, keep away from any signal and/or speaker lines to avoid noise in the system.

Remote Turn-On wire should be coming from the source unit, so the amplifier turns on/off with the source.

② FUSES

Fuse rating is a total of 30 A. The unit is equipped with two 15 A fuses.

Always replace the fuses with the same type and value.

③ HIGH-LEVEL (Speaker Level) INPUTS

If your source unit does not have Full-Range RCA Pre-Amp Outputs, you can use the speaker outputs to the P8.2UAW.

④ CH1/2 SPEAKER OUTPUTS

Connect to the Front or Rear speakers in your vehicle. Always Observe Polarity!

⑤ RCA INPUTS (LOW LEVEL)

Please note the inputs MUST be Full-Range from the source unit. Otherwise, CH 1/2 outputs will not output correctly.

If the pre-amp of the source unit is not Full-Range, the speaker level input should be used.

Use the supplied harness and connect the outputs as shown in the connection diagram in this manual.

⑥ ILLUMINATION

The unit is equipped with an illumination feature that can be turned ON/OFF via the switch.

The illumination if ON will turn on when the Remote terminal receives power.

RCA Inputs (Low Level)

RCA cables are preferred for best audio performance.

Installation lengths will vary due to sizes.

Always connect with the high-quality cables to avoid any induced noise.

NOTE: DO NOT USE/CONNECT BOTH HIGH-LEVEL AND RCA INPUTS AT THE SAME TIME

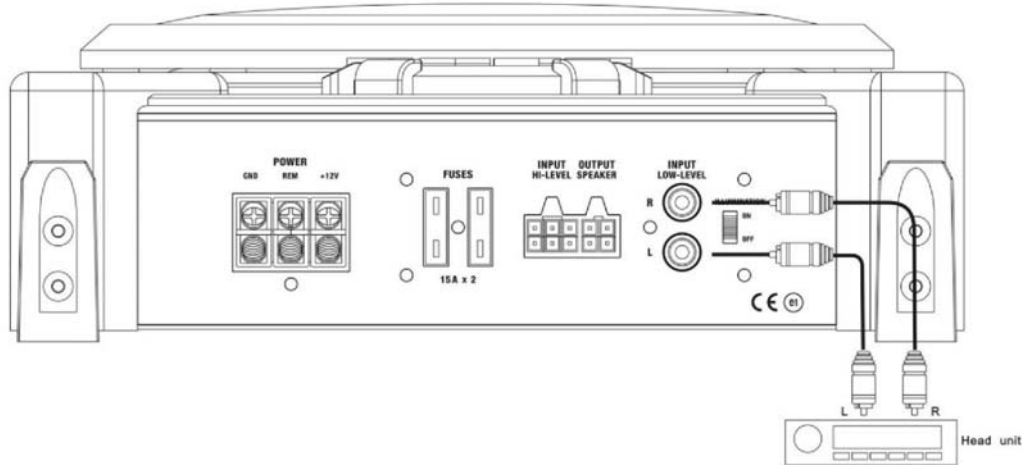

Speaker Input (High-Level)

The high-level input(s) should only be used when your receiver lacks Full-Range RCA Outputs.

If the RCA outputs are not present, connect the speaker outputs from the receiver to the high-level input connector of the amplifier. Be sure to observe polarity to avoid audio phase problems.

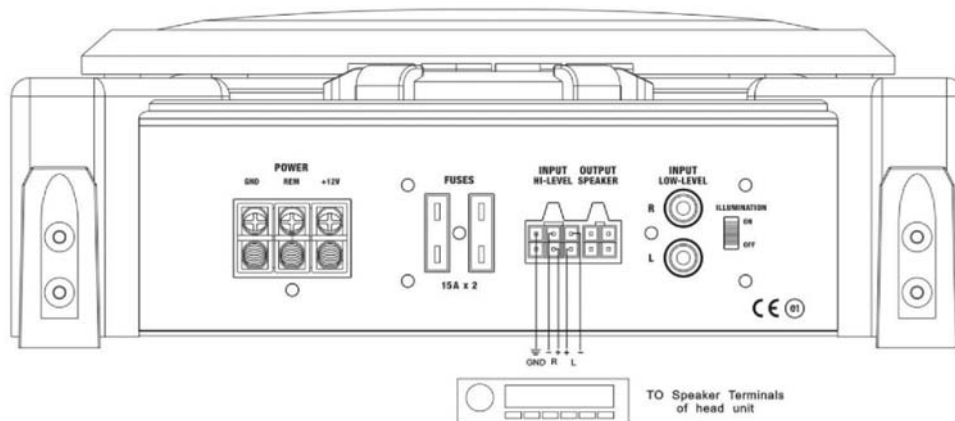

High-Level Input & Speaker Output Wiring

The high-level input(s) should only be used when your receiver lacks Full-Range RCA Outputs.

If the RCA outputs are not present, connect the speaker outputs from the receiver to the high-level input connector of the amplifier. Be sure to observe polarity to avoid audio phase problems.

Connect to the full-range front or rear speakers in your car.

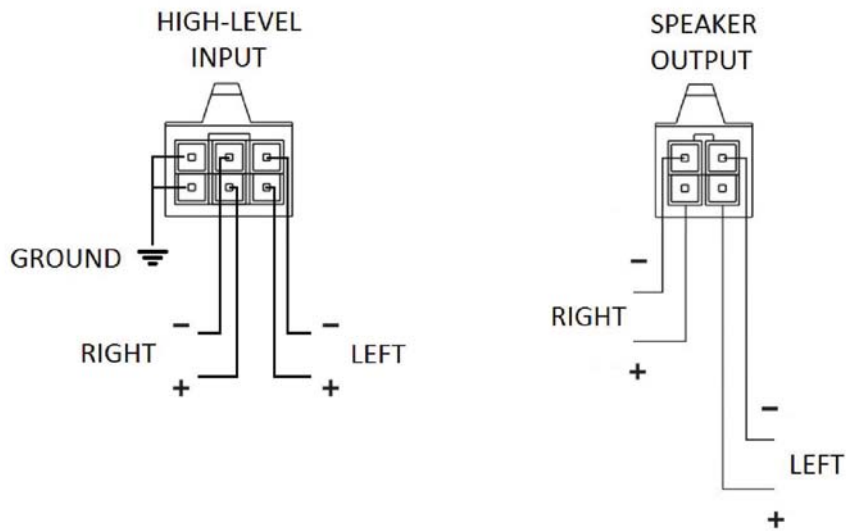
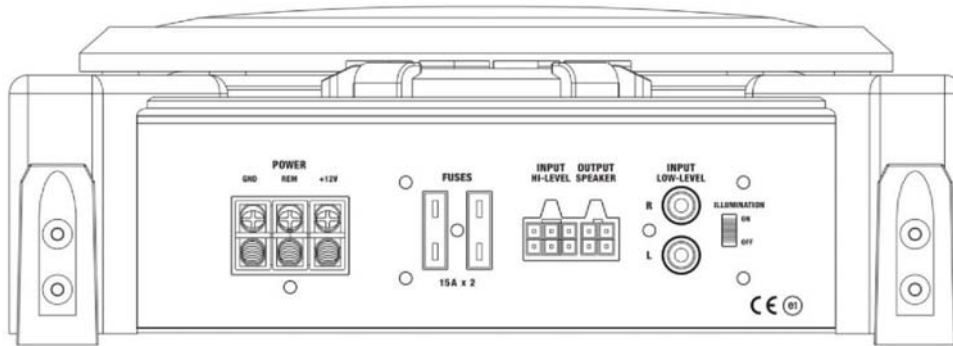

Power Input Connections

Connect the ground terminal to the closest point on the chassis of the vehicle.

Keep this ground wire to less than 3 ft. (36") in length.

Use a high quality OFC 8 gauge wire.

Connect the remote terminal to the remote output of the head unit to "REM" using 16 gauge wire.

Connect an empty fuse holder within 18" of the car battery, and run 8 gauge cable from this fuse to the amplifier location.

Then connect the fuse holder to the "+12V"

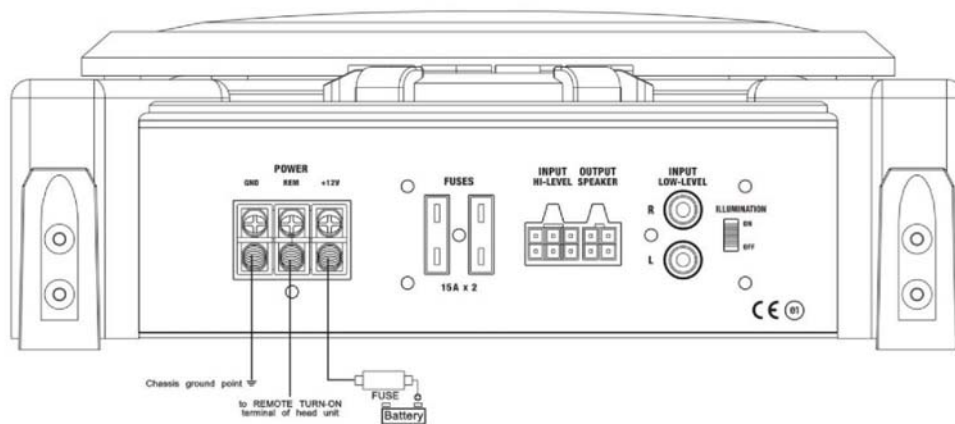

Subwoofer Level Control

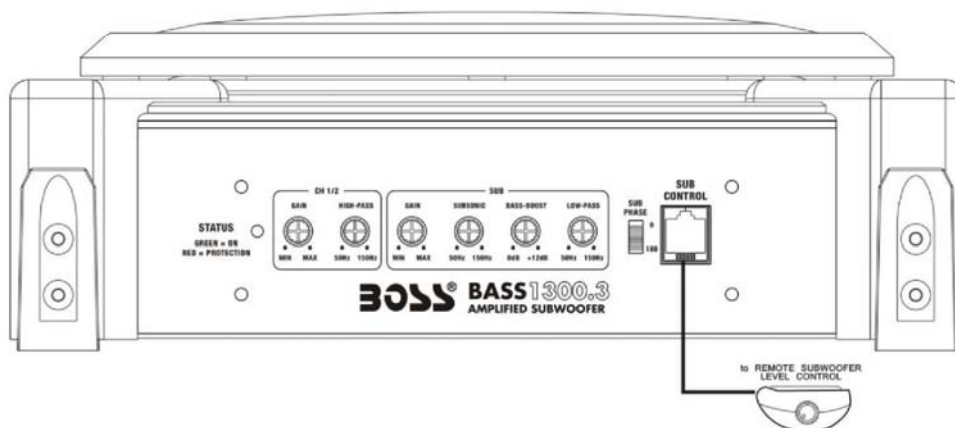

Subwoofer Remote Control allows you raise to lower the level of the subwoofer independently from the other two outputs channels.

Mounting the subwoofer

1. Find a suitable location in the vehicle in which to mount the amplifier. An optional location is shown below:

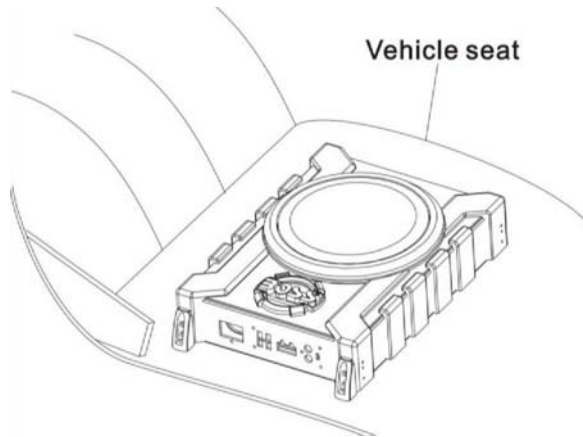

2. Make sure there is sufficient air circulation around the intended mounting location.

3. The mounting feet have multiple mounting locations.

4. Before drilling any holes or screws, double check you're not about to drill into any fuel lines, brake lines, cables, etc...

Troubleshooting

If you experience operation or performance problems with this product, compare your installation with the electrical wiring diagrams on the previous pages. If problems persist, read the following troubleshooting guide which may help.

If you have any further questions, please give our Tech Department a call.

Amplifier will not power up	<p>Check to make sure you have a good ground connection Check that the remote input (turn-on) has at least 9VDC Check that there is battery power on the (+)terminal Check that there is at least 12v Check all fuses, replace if necessary Make sure that the protection led is not illuminated. If it is lit, Shut off the amplifier briefly, and then power it ON again</p>
Protection LED comes on when Amplifier is powered up	<p>Turn down the volume control on the head until to prevent overdriving. If it remains on, please contact our Tech Dept.</p>
No output	<p>Check that all fuses are ok Check that unit is properly grounded. Check that the remote input (turn-on)has at least 9VDC Check that the RCA audio cables are plugged into the proper Inputs. Check all speaker wiring.</p>
Low output	<p>Reset the level control Check the crossover control settings.</p>
High hiss in the sound	<p>Disconnect all RCA inputs to the power sub's control panel. If the hiss disappears, then plug in the component driving the amplifier and unplug its inputs. If the hiss disappears at this point ,go on Until the faulty/noisy component is found. It is best to set the amplifier's input level control as low as Possible</p>
Squealing noise is present	<p>Check all cables</p>
Distorted sound	<p>Check that the input level control is set to match the signal level of the source unit. Always try to set the input level as low as possible. Check that all crossover frequencies are properly set. Check for broken or damaged cable insulation on the speaker leads.</p>
Amplifier gets very hot	<p>Check that there is good air circulation around the amp. Adjust the input gain to properly match the source unit</p>
Engine noise	<p>This is usually caused by poor quality RCA cables, which can pick up radiated noise. Use only the best quality cables, and route them away from any power cables.</p>
Engine noise (alternator whine)	<p>Check that the RCA grounds are not shorted to the vehicle chassis. Check that the source unit is properly grounded. Check the ground connection is clean and any paint is scraped away.</p>

Specifications

Maximum Power	800 W + (250 W @ 2 Ohm)
THD	< 0.1%
S/N Ratio	>88db
Frequency Response	20 Hz - 150 Hz
Input Sensitivity	100 mV - 6 V
Low Pass Filter	50 Hz – 150 Hz @ 12dB/Oct
Subsonic Filter	20 Hz – 50 Hz @ 6dB/Oct
Bass Boost @ 45 Hz	0 to +12 dB
Fuse Rating	15 A
Dimensions	9-7/8" x 13-7/8" x 3" (251x352x76mm)

USER'S MANUAL MANUAL DEL USUARIO

BASS1300.3

800 WATTS | 8" (203mm) LOW PROFILE AMPLIFIED SUBWOOFER

PLUS 250 WATTS x 2 AMPLIFIED SPEAKER OUTPUTS

800 WATTS | 8" (203mm) SUBWOOFER AMPLIFICADO DE PERFIL BAJO

MÁS 250 WATTS X 2 SALIDAS DE ALTAVOZ

BOSS[®]
AUDIO SYSTEMS

BOSS Audio Systems

3451 Lunar Court • Oxnard, CA 93030

www.bossaudio.com | 805.751.4853

tech support: www.bossaudio.com/technical-support



0815