





ASSEMBLY INSTRUCTION

ITEM# 6960-75206-81 60in Friendship Table w/2-12in Leaves

**Caution: Please make sure you have all parts indicated below prior to assembly.
This table is heavy and can best be assembled with the help of two or more people.**

NO.	HARDWARE LIST		Q'TY
A		Allen Wrench	1
B		Bolt	6
C		Lock Washer	6
D		Flat Washer	6

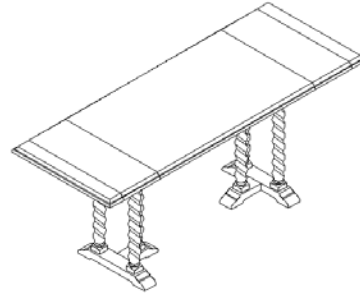

Note:

1. Leaves cannot be switchable. Follow numbers on leaves and top when assemble.
2. Height of this table can be adjusted with or without extension blocks.

Assembly steps without extension blocks (30" height):

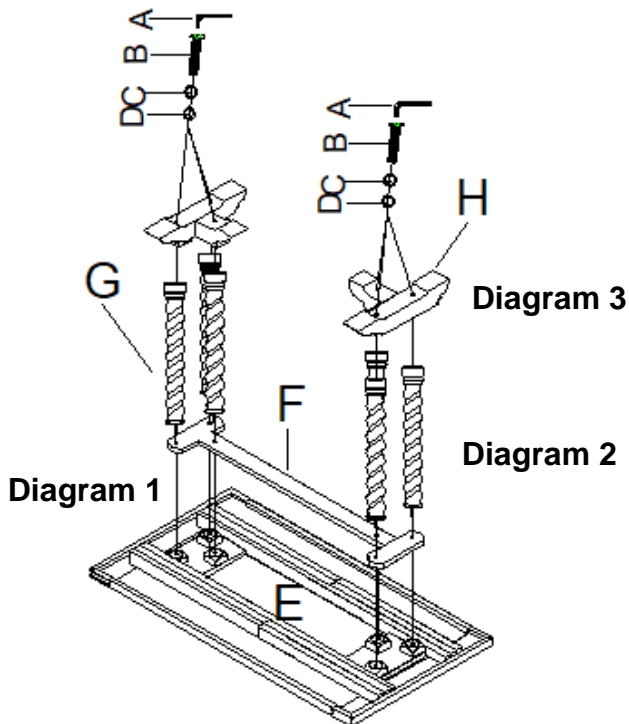

1. Place table top (E) upside down on a soft surface to prevent it from being scratched.
2. Place stretcher (F) onto top, make sure pre-drilled holes on stretcher are aligned with holes on top. (See Diagram 1)
3. Screw posts (G) through stretcher (F) to top by turning in clockwise direction. (See diagram 2)
4. Place bases (H) onto posts and make sure all pre-drilled holes are in alignment, well insert flat washers (D), lock washers (C) and bolts (B), tighten all with allen wrench (A). (See Diagram 3)
5. Turn desk upright.

Assembly steps with extension blocks (36" height):

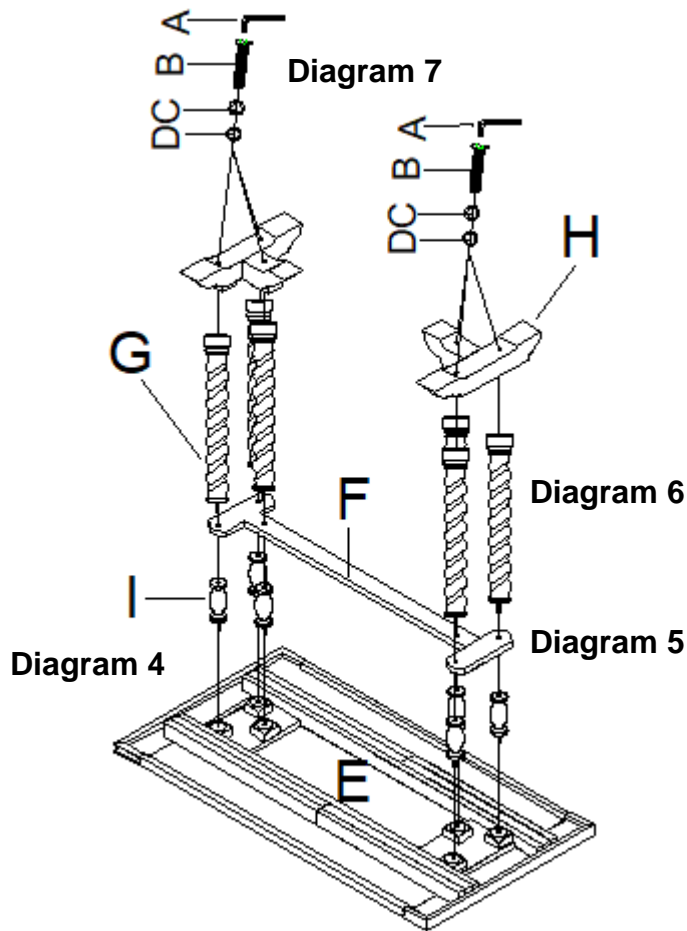

1. Place table top (E) upside down on a soft surface to prevent it from being scratched.
2. Screw extension blocks (I) to top by turning with clockwise direction. (See Diagram 4)
3. Place stretcher (F) onto extension blocks, make sure all pre-drilled holes are aligned. (See Diagram 5)
4. Screw posts (G) through stretcher (F) to extension blocks (I) by turning in clockwise direction. (See Diagram 6)
5. Attach bases (H) and follow the assembly step 4 of above without extension blocks indicated. (See Diagram 7)

Instruction for table leaves:

1. There are latches at the bottom of table top, turn off the latches as shown in Diagram 8.
2. Pull out table top as the arrow direction shown in Diagram 9.
3. Follow numbers on table leaves and top, place table leaves between and push table tops together.
4. Turn on latches. (See Diagram 8)
5. Take opposite actions to remove table leaves.

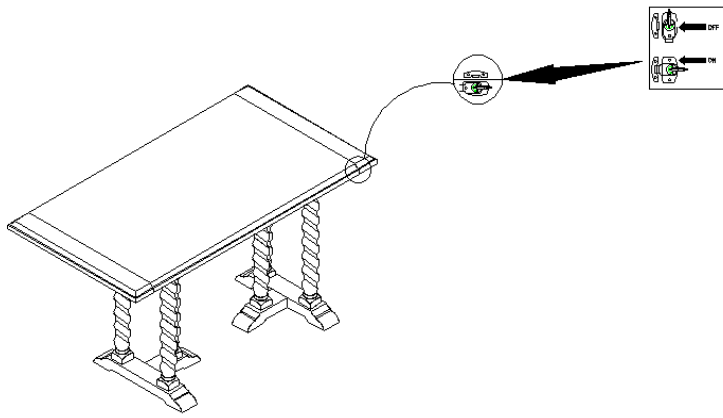

Diagram 8

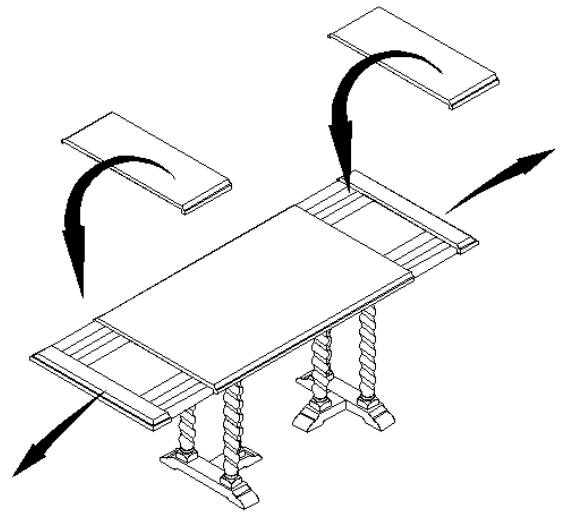

Diagram 9

Cleaning Instruction: Clean finished parts with a mild dishwashing liquid and water solution on a damp cloth. Polish the finish with soft cloth and an industry recognized furniture polish.