

INSTRUCTION MANUAL

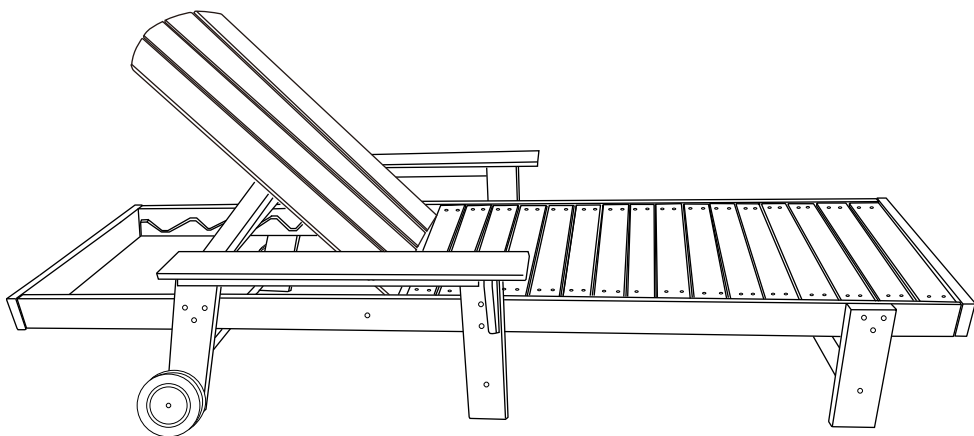

**Laguna Adirondack Poly Reclining Chaise
Lounge With Arms & Wheels
SKU: OP4007**

V1.0

! NOTICE

Do not overtighten screws. (Insert all screws before tighten screws.)

- Please do not exceed the weight limitations of this item.
- Do not stand on or use any part of this item as a step ladder.
- Firmly secure all bolts, screws and nuts before use.
- Reconfirm that all bolts, screws, and nuts are secure every 90 days.
- Do not use or store this item in the proximity of open flame or flammable/combustible chemicals.
- Be aware that some parts are heavy and have sharp edges.
- Be very careful when adjusting lounge backrest to avoid smashing your hands or fingers.

TOOLS REQUIRED



ALLEN WRENCH
(PROVIDED)



WRENCH
(PROVIDED)



LOUNGE
330 LBS
CAPACITY



1 PERSON
ASSEMBLY



UP TO 30 MIN.
ASSEMBLY

HARDWARE

1 M6 x 60mm
BOLT



6 PCS

2 M6 x 50mm
BOLT



22 PCS

3 M6 x 50mm
SCREW



4 PCS

4 M6 x 40mm
BOLT



2 PCS

5 M8 x 30mm
CAP NUT



1 PC

6 M6 NUT



6 PCS

7 M6 WASHER



8 PCS

8 WRENCH



1 PC

9 M6 ALLEN
WRENCH

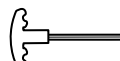

1 PC

10 M4 ALLEN
WRENCH

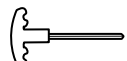

1 PC

PARTS

A LOUNGE BASE

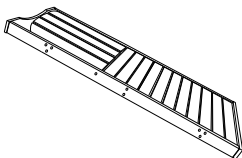

1 PC

B FRONT LEG



2 PCS

C RAIL

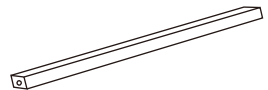

3 PCS

PARTS

D

ARM SUPPORT



2 PCS

E

RIGHT CHAIR ARM

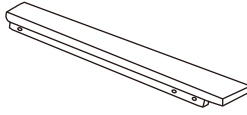

1 PC

F

LEFT CHAIR ARM

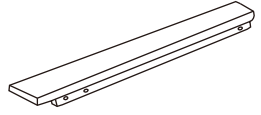

1 PC

G

MIDDLE LEG - RIGHT

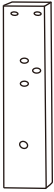

1 PC

H

MIDDLE LEG - LEFT



1 PC

I

LEFT REAR LEG

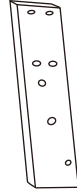

1 PC

J

RIGHT REAR LEG

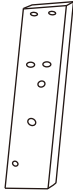

1 PC

K

WHEEL

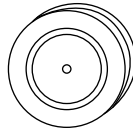

2 PCS

PRODUCT ASSEMBLY - OVERALL VIEW

Look at following overall view of this Lounge and learn the exact position of each parts to be assembled.

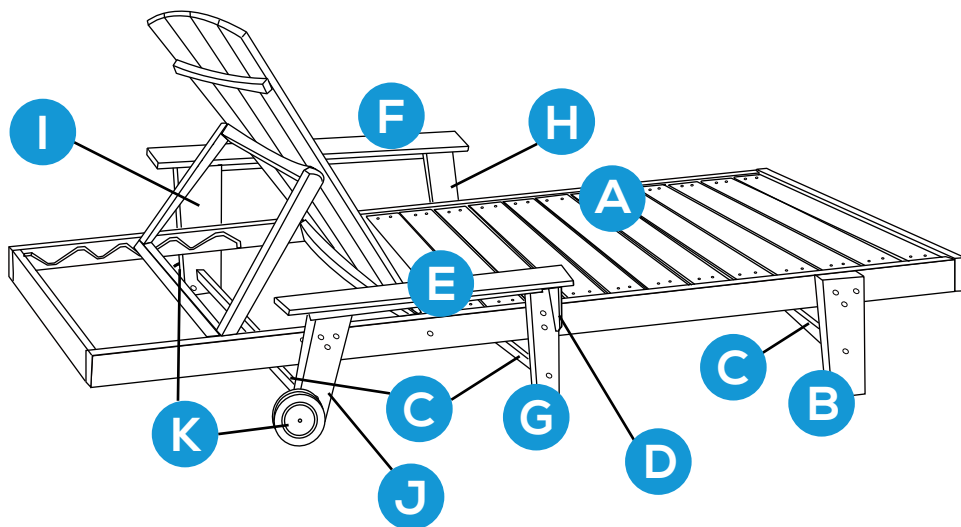

PRODUCT ASSEMBLY

1

Attach part D Arm support to part H Middle Leg - Left with 2 PCS of hardware 3 Screw.

Do the same to attach another arm support to part G Middle Leg - Right.

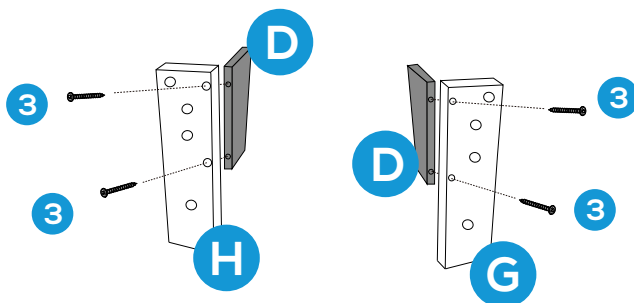

PRODUCT ASSEMBLY

2

Attach part F Left Chair Arm to part I Left Rear Leg and the assembled part (H + D) with 3 sets of hardware 1 bolt, hardware 7 washer and hardware 6 Nut.

Do the same to assemble part E Right Chair Arm with part J Right Rear Leg and the assembled part (G + D).

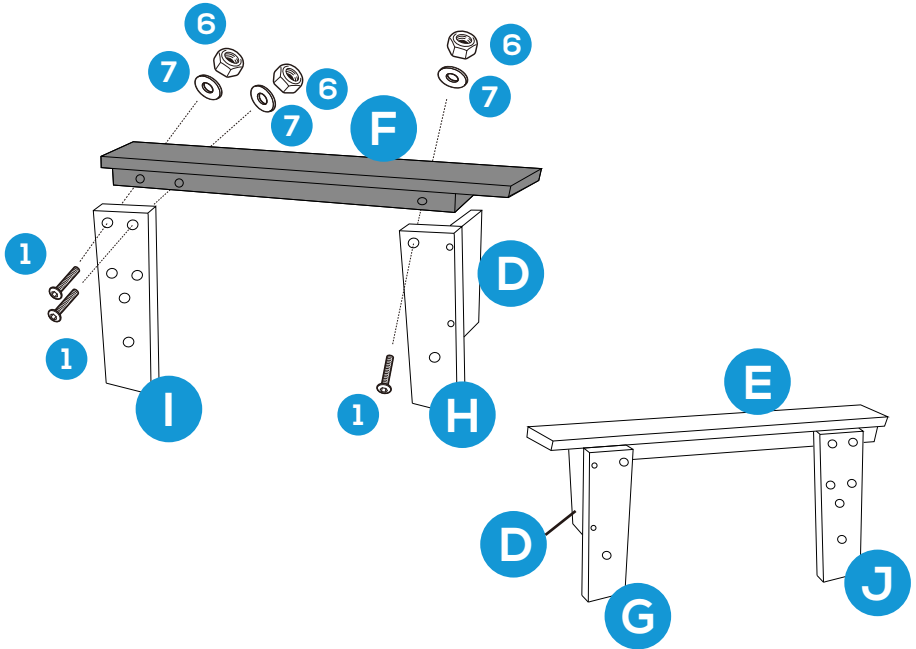

3

Place right side of the Lounge on smooth ground as below.

Attach the combined part (I + F + H) to the left side of the lounge with 5 pcs of hardware 2 Bolt.

Attach part B Front Leg to the left side of the lounge with 3 pcs of hardware 2 Bolt.

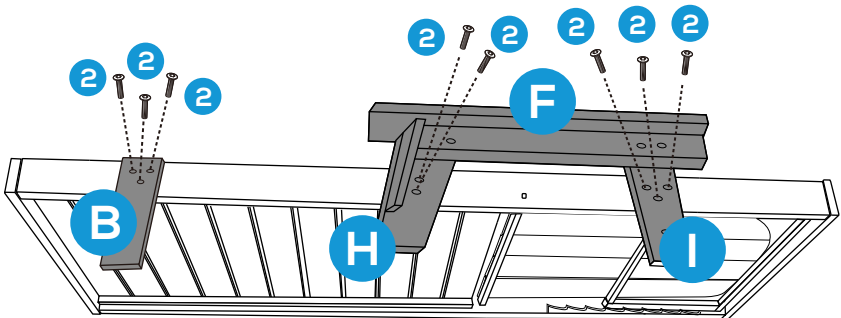

PRODUCT ASSEMBLY

4

Attach part C Rail to part B the front leg with 1 pc of hardware 2 Bolt.

Do the same to attach the other 2 pcs of part C Rail to part H Middle Leg-Left & part I Left Rear Leg with 2 pcs of hardware 2 Bolt.

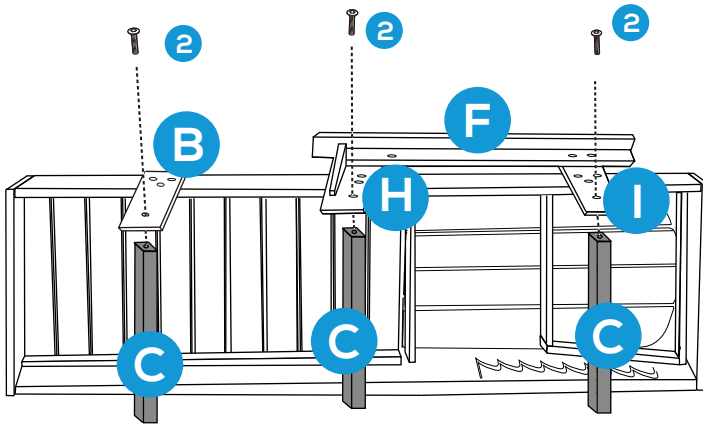

5

Place the lounge upside down, attach the combined part (J + E + G) to the right side of the lounge with 5 pcs of hardware 2 Bolt.

Attach part B Front Leg to the right side of the lounge with 3 pcs of hardware 2 Bolt.

Attach part C Rails to part B Front Leg, part G Middle Leg-Right & part J Right Rear Leg with 3 pcs of hardware 2 Bolt.

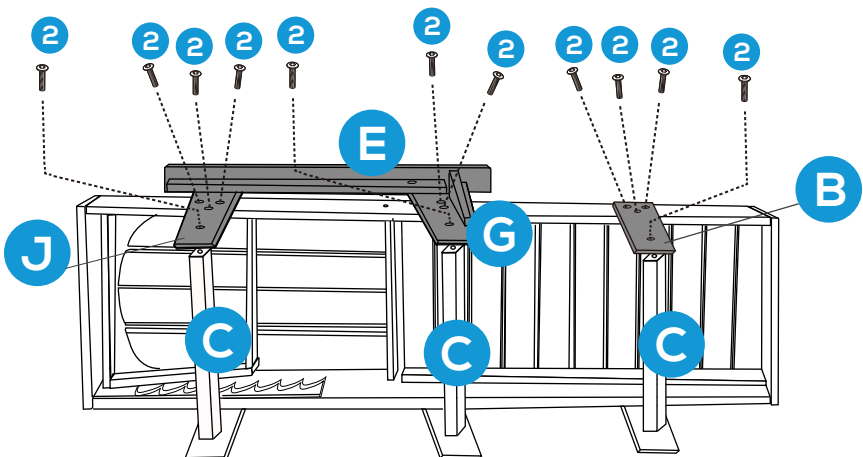

PRODUCT ASSEMBLY

6

Attach 2 pcs of part K Wheels to the rear legs of the lounge with 2 sets of hardware 4 Bolt and hardware 5 Cap Nut as well as 2 pcs of hardware 7 Washer.

Remark: Hardware 7 washer should be put between the wheel & rear leg for easy movement.

Adjust the backrest to a comfortable position and lock the back support to the bracket.

