

WALKER EDISONTM

Holmes L-Shaped Desk

SKU# AZHOL42OS1

Option A

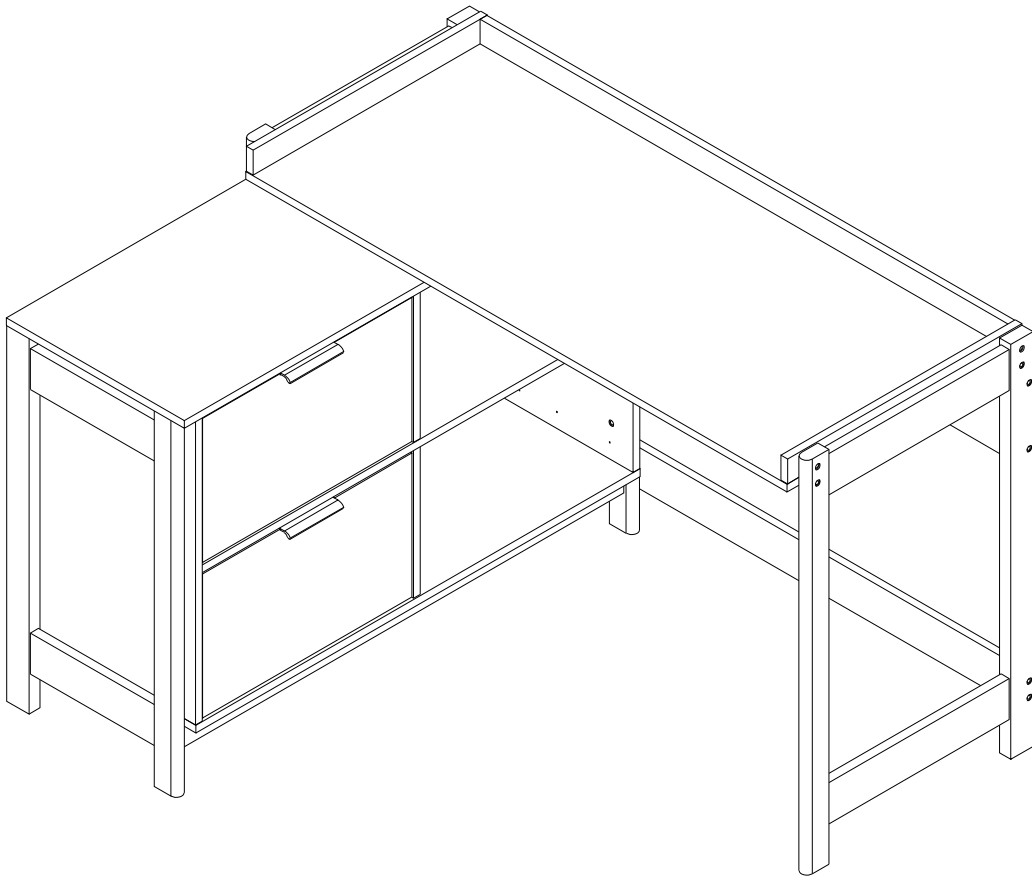

For Residential Use Only

Please visit our website for the most current instructions, assembly tips, report damage, or request parts. www.walker-edison.com



Time to get started

Set up a clean and soft workplace to get started and avoid damage during the assembly. It also helps to double-check that you've got all the pieces and parts before diving in to assembly.

Estimated time for assembly

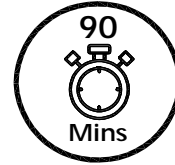

People recommended for assembly

Make it a team effort! Grab a friend for quicker, easier assembly.

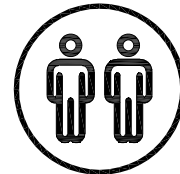

2 People Build

Tools Needed

Grab a Phillips head screwdriver to conquer this assembly

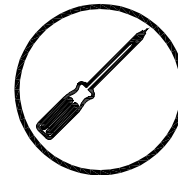

Use power tools with caution

You can cause cracking or damage to the material and easily strip the hardware. If you choose to use a power tool, your product will no longer be covered under Walker Edison's warranty.

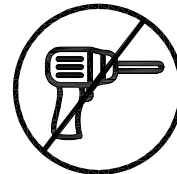

Glue is provided to secure wood dowels in place

When inserting dowels, locate the appropriate hole, place a small amount of glue in the hole, and then insert the dowel. Wipe away excess glue immediately.

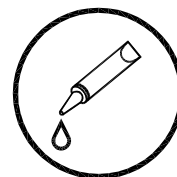

Holmes

Scan to get assembly tips and help!







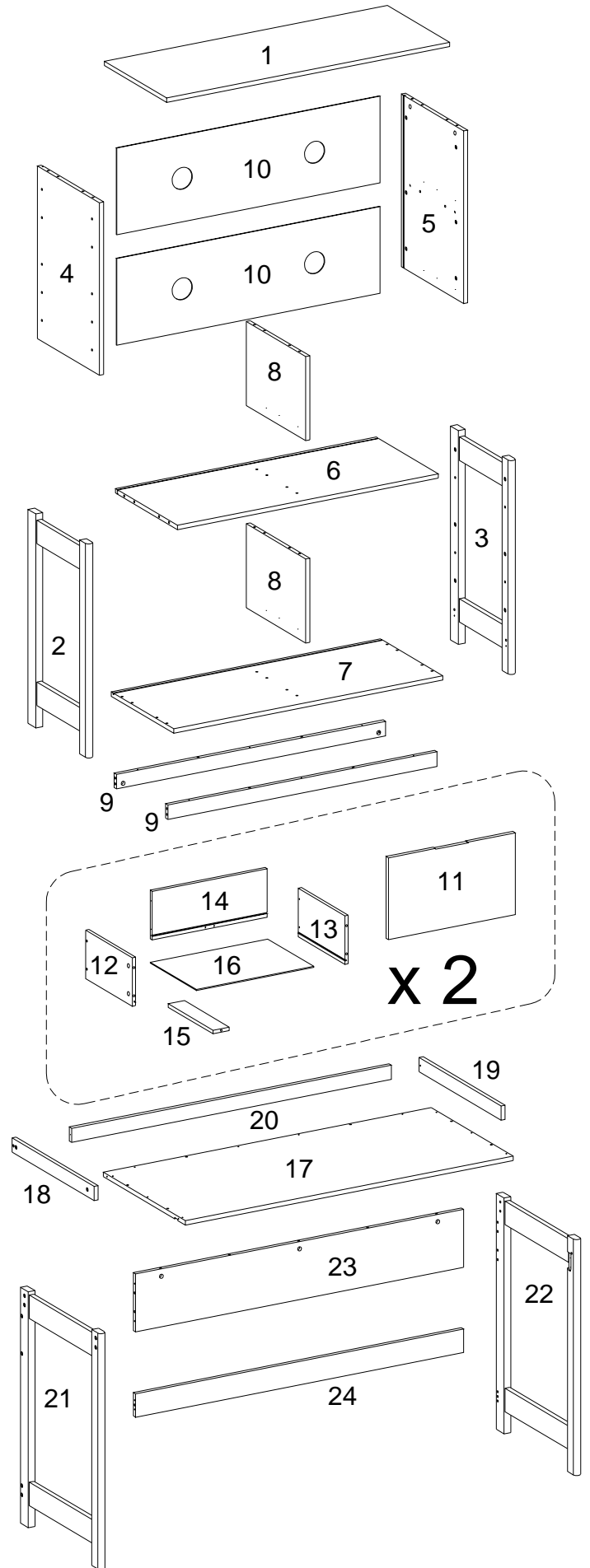



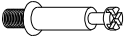

Parts List

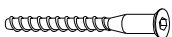
Part Number	Description	Quantity
1	Top Cabinet Panel	1
2	Left Cabinet Foot Frame	1
3	Right Cabinet Foot Frame	1
4	Left Cabinet Panel	1
5	Right Cabinet Panel	1
6	Shelf	1
7	Bottom Cabinet Panel	1
8	Cabinet Divider Board	2
9	Cabinet Trim Panel	2
10	Cabinet Back Panel	2
11	Drawer Front	2
12	Drawer Left Panel	2
13	Drawer Right Panel	2
14	Drawer Back Panel	2
15	Drawer Support	2
16	Drawer Bottom	2
17	Desktop	1
18	Desk Left Trim Panel	1
19	Desk Right Trim Panel	1
20	Desk Back Trim Panel	1
21	Left Desk Foot Frame	1
22	Right Desk Foot Frame	1
23	Back Desk Panel	1
24	Desk Bottom Trim Panel	1



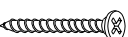
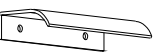

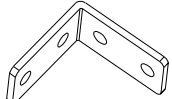



Hardware List

Part	Size	Name	Quantity
A	 8x30mm	Wooden dowel	50
B	 6x35mm	Cam bolt	29
C	 15x11mm	Cam lock	19
D	 15x9mm	Cam lock	10
E	 6x50mm	Bolt	20
F	 6x35mm	Bolt	4
G	 6x25mm	Bolt	12
H	 M4x57mm	Hex Key	1
J	 4x38mm	Screw	24
K		Drawer pull	2
L	 3x12mm	Screw	28
M		L-shape bracket	2
N	 4x12mm	Screw	8

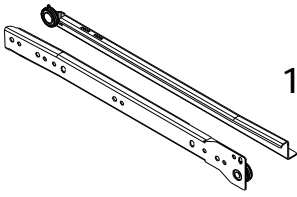
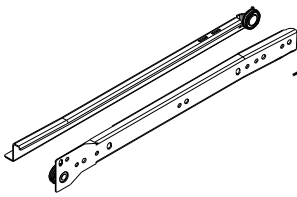

Hardware List

Part	Size	Name	Quantity
P	 4x45mm	Screw	6
Q		Plastic wedge	12
R	 3x17mm	Screw	12
S	 12"	Drawer Glide*	2 Set
T	 12"	Drawer Glide*	2 Set
U	 30mm	Sticker	29
W		Glue tube	2

The hardware quantities listed above are required for proper assembly.
Extra hardware pieces may be included.

Step 1

Let's get started! Insert Wooden dowels (A) into the corresponding spots in the Left Cabinet Panel (4). Then, using a Phillips head screwdriver, screw the Cabinet member side of the (S) Drawer Glides into the Left Cabinet Panel (4) using the (L) Screws. On the Drawer Glide (S) in the middle of the Left Cabinet Panel (4), insert Cam bolts (B).

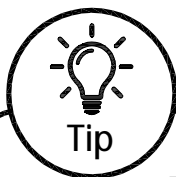
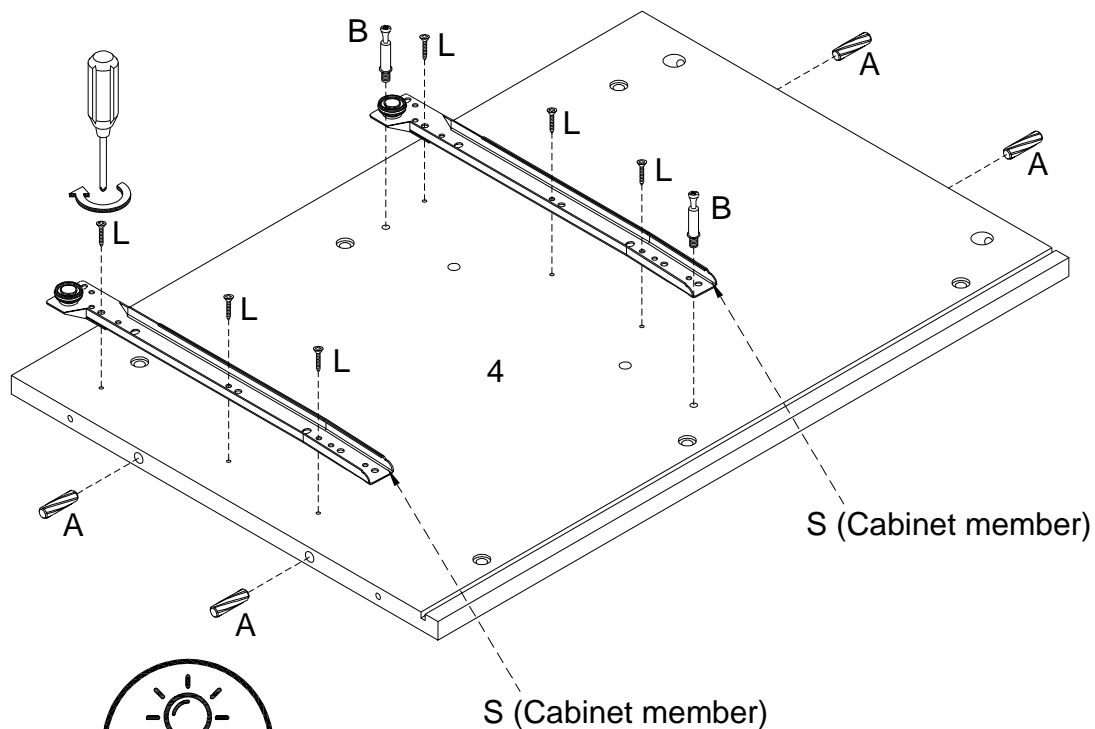

Tip

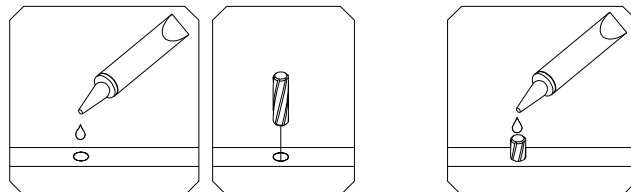

1: The provided glue is to secure wood dowels in place. When first inserting dowels, locate the appropriate hole for the dowel, place a small amount of glue in the hole and insert the dowel. Wipe away excess glue immediately.

2: In future assembly steps when dowels are necessary to attach assembly parts together, place a small amount of glue on the end of the dowel before attaching parts together. Wipe away excess glue immediately.

Step 2

Now, follow that same process for the Cabinet Divider Boards (8)! Insert Wooden dowels (A) into the corresponding spots in the Cabinet Divider Boards (8). Screw the Cabinet member side of the (T) Drawer Glide into each Cabinet Divider Board (8) using the (L) Screws.

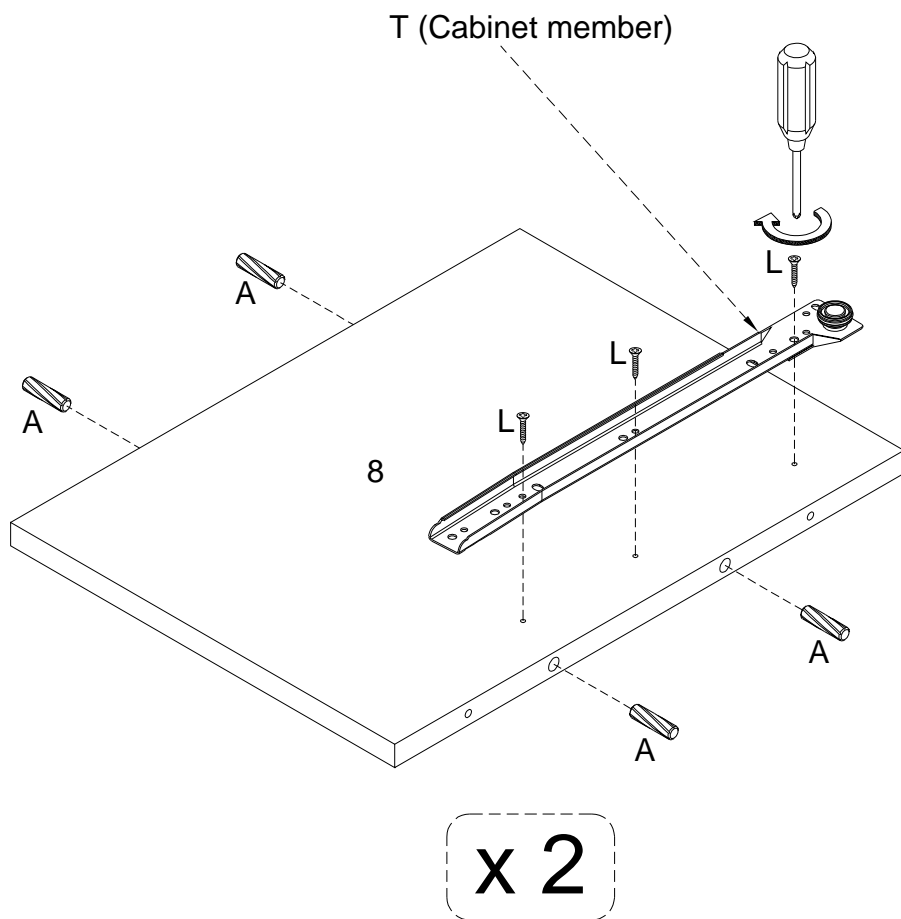

Step 3

Insert Wooden dowels (A) into both the Right Cabinet Panel (5) and the Shelf (6). Then, screw Cam bolts (B) into both pieces.

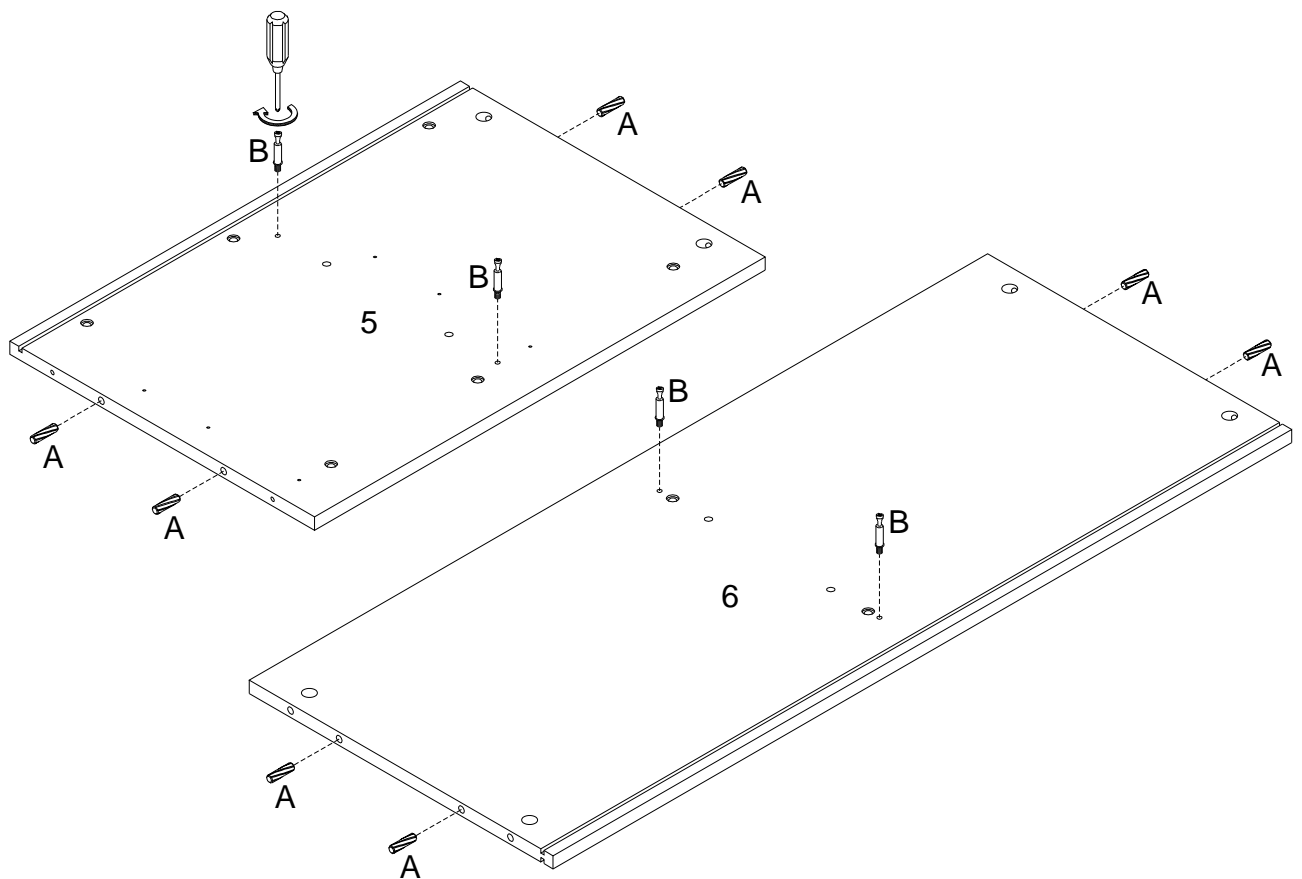

Step 4

Making sure the finished edge of the Cabinet Divider Board (8) is facing out, secure the Cabinet Divider Board (8) to the Shelf (6) using the (E) Bolts. Tighten with the Hex key.

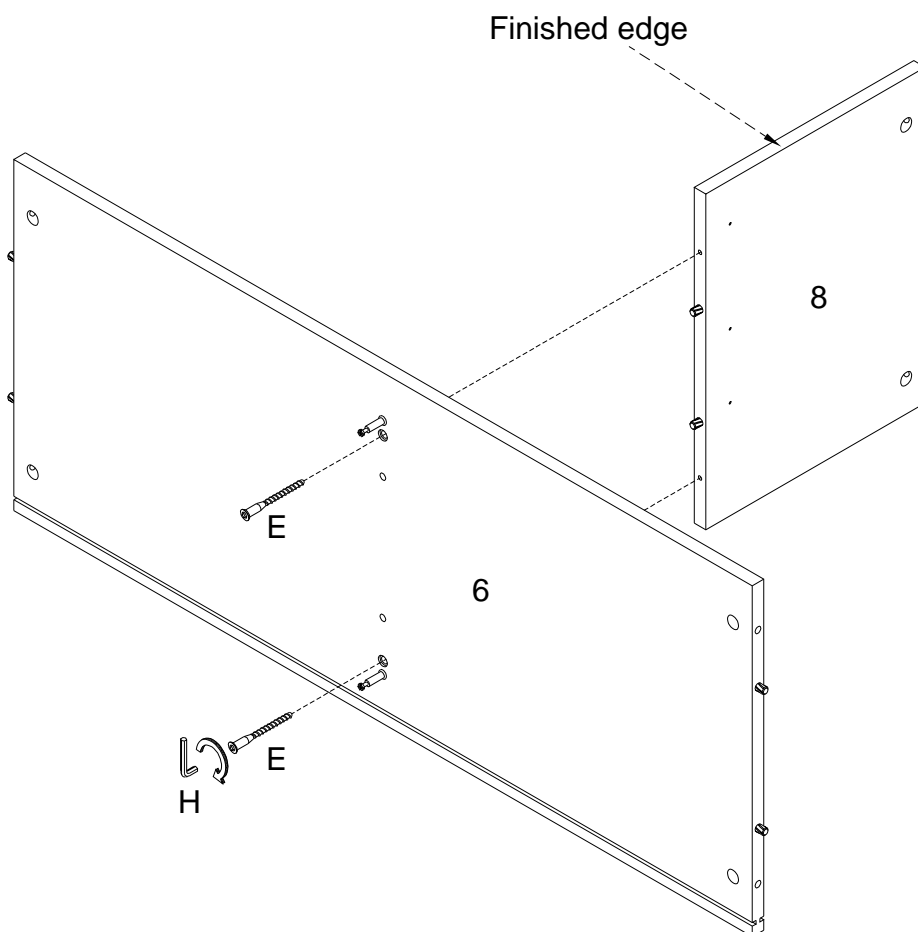

Step 5

While still ensuring that the finished edge of the Cabinet Divider Board (8) is facing out, secure the Cabinet Divider Board (8) to the other side of the Shelf (6) using the (C) Cam locks. Tighten with a screwdriver!

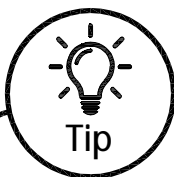
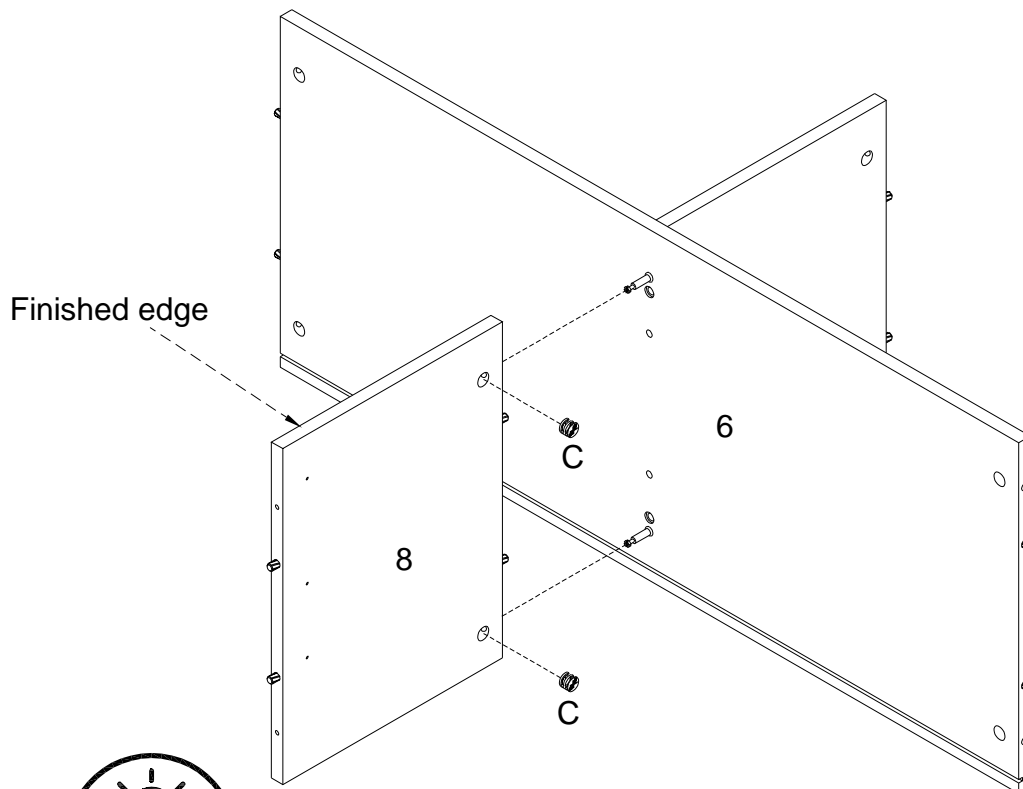

Cam Locks

Cam Locks help securely join two pieces together. Follow these easy steps.

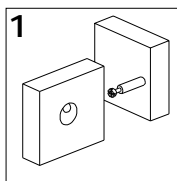

1: Insert Cam Bolt into bolt holes on the flat side. Don't over tighten!

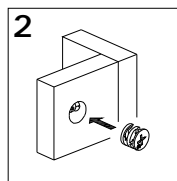

2: Fit the proper holes on the edge of the other part over the Cam Bolts. You should be able to see the cam bolts through the larger hole on the side.

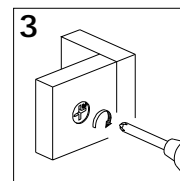

3: On the back of the Cam Lock will be a "C" shape. Insert the Cam Lock so the opening of the "C" fits over the Cam Bolt. Tighten with the screwdriver.

Step 6

Secure the right side of the Shelf (6) to the Right Cabinet Panel (5) using the (C) Cam locks. Tighten with a screwdriver.

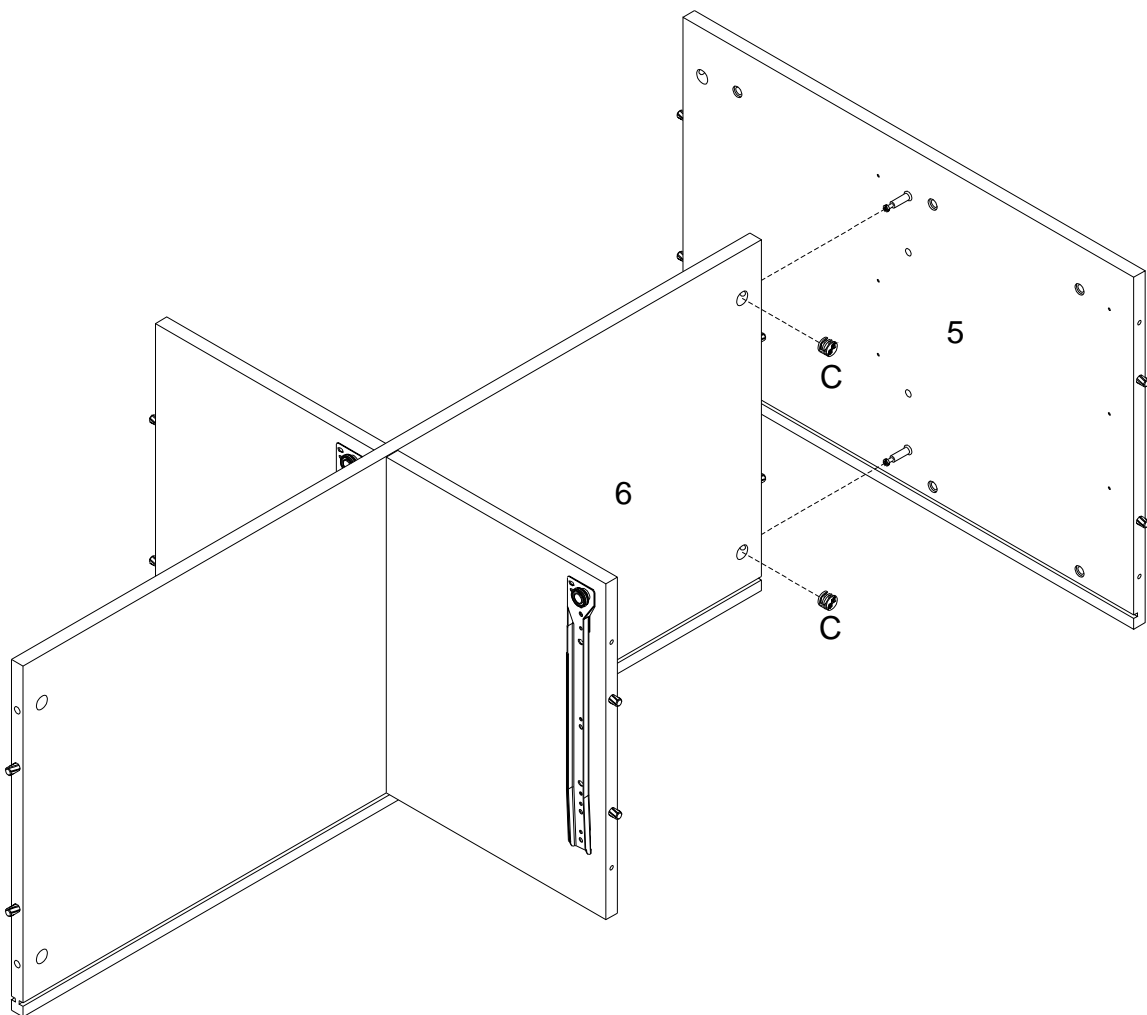

Step 7

Now, repeat that for the other side! Secure the left side of the Shelf (6) to the Left Cabinet Panel (4) using the (C) Cam locks. Tighten with a screwdriver.

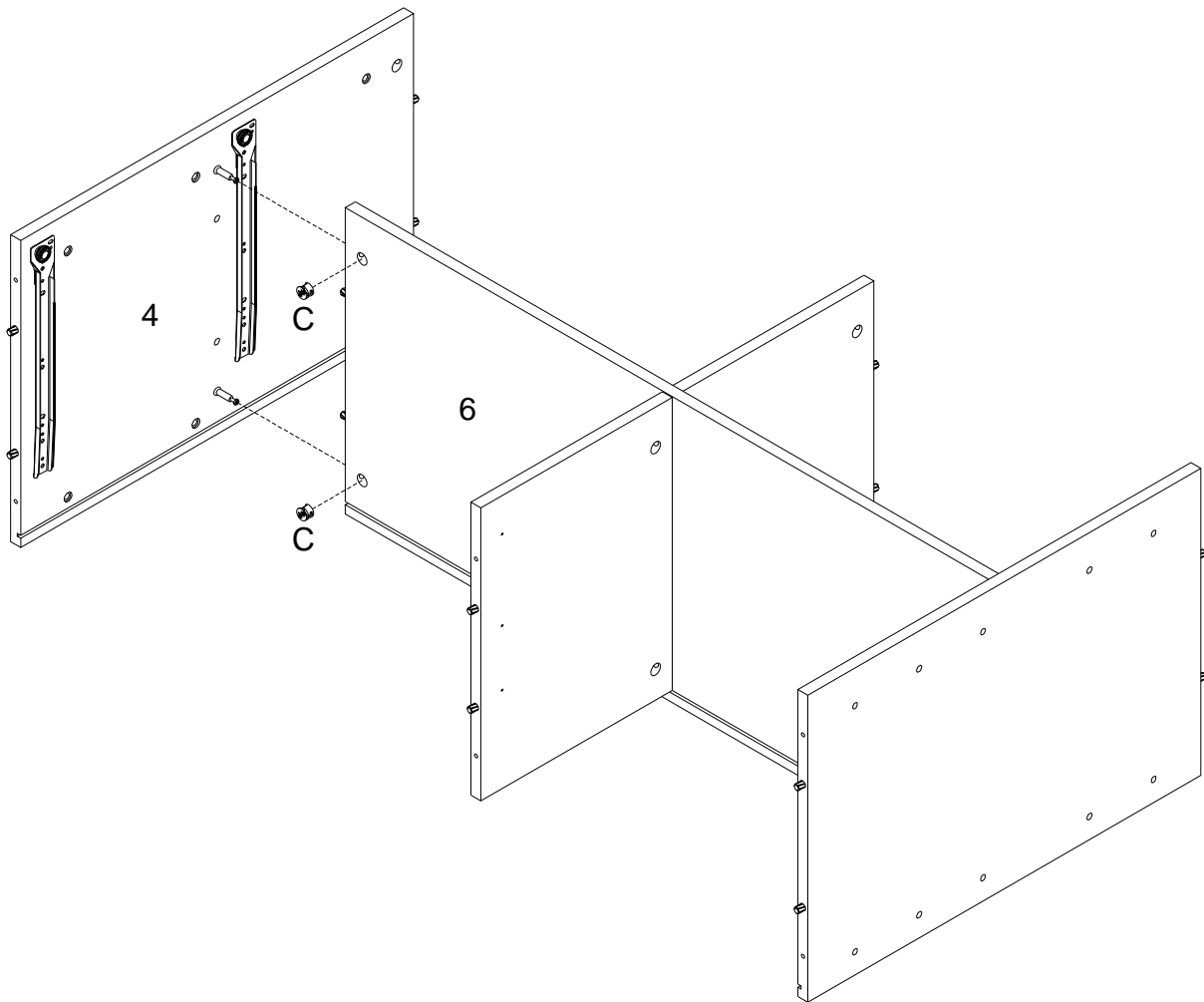

Step 8

Slide one Cabinet Back Panel (10) into place using the grooves as a guide.

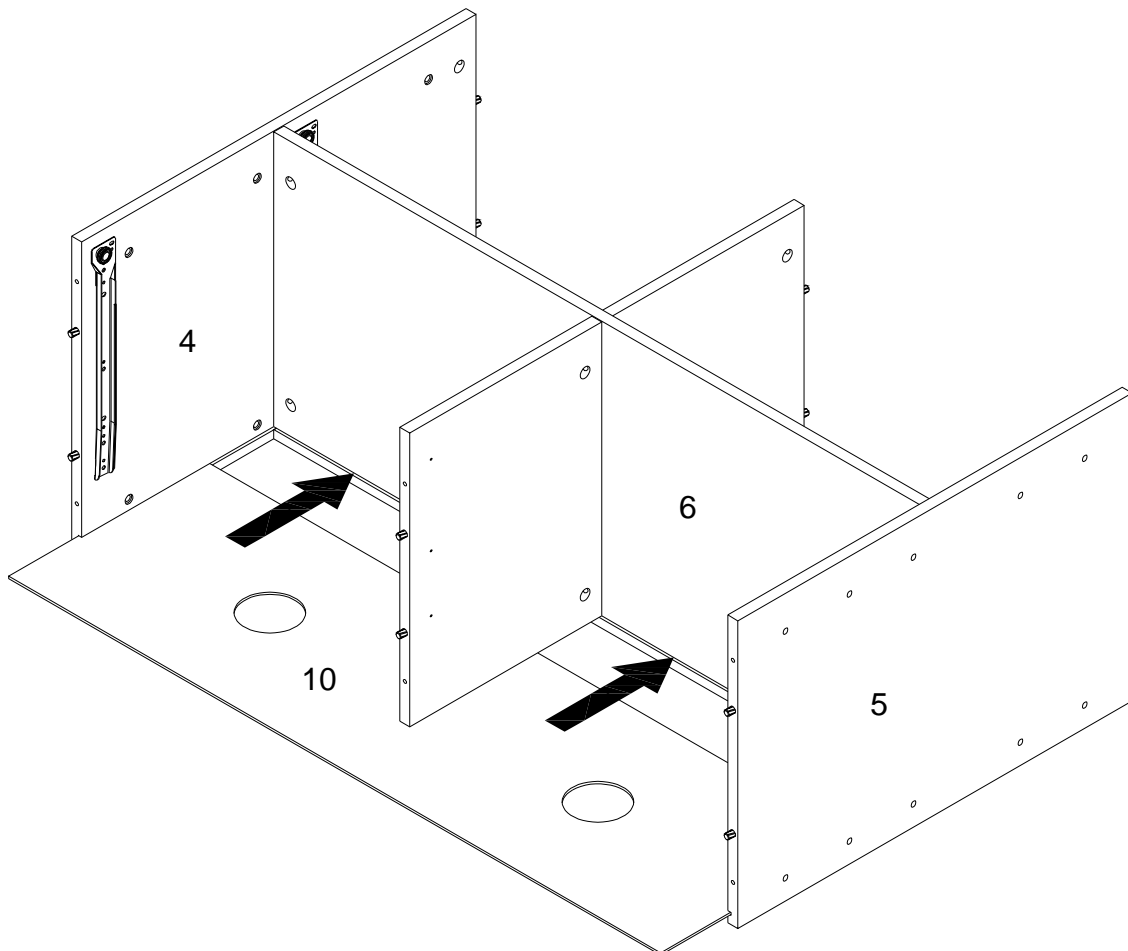

Step 9

Secure the Bottom Cabinet Panel (7) to the rest of the unit using the (E) Bolts. Tighten with the provided Hex key.

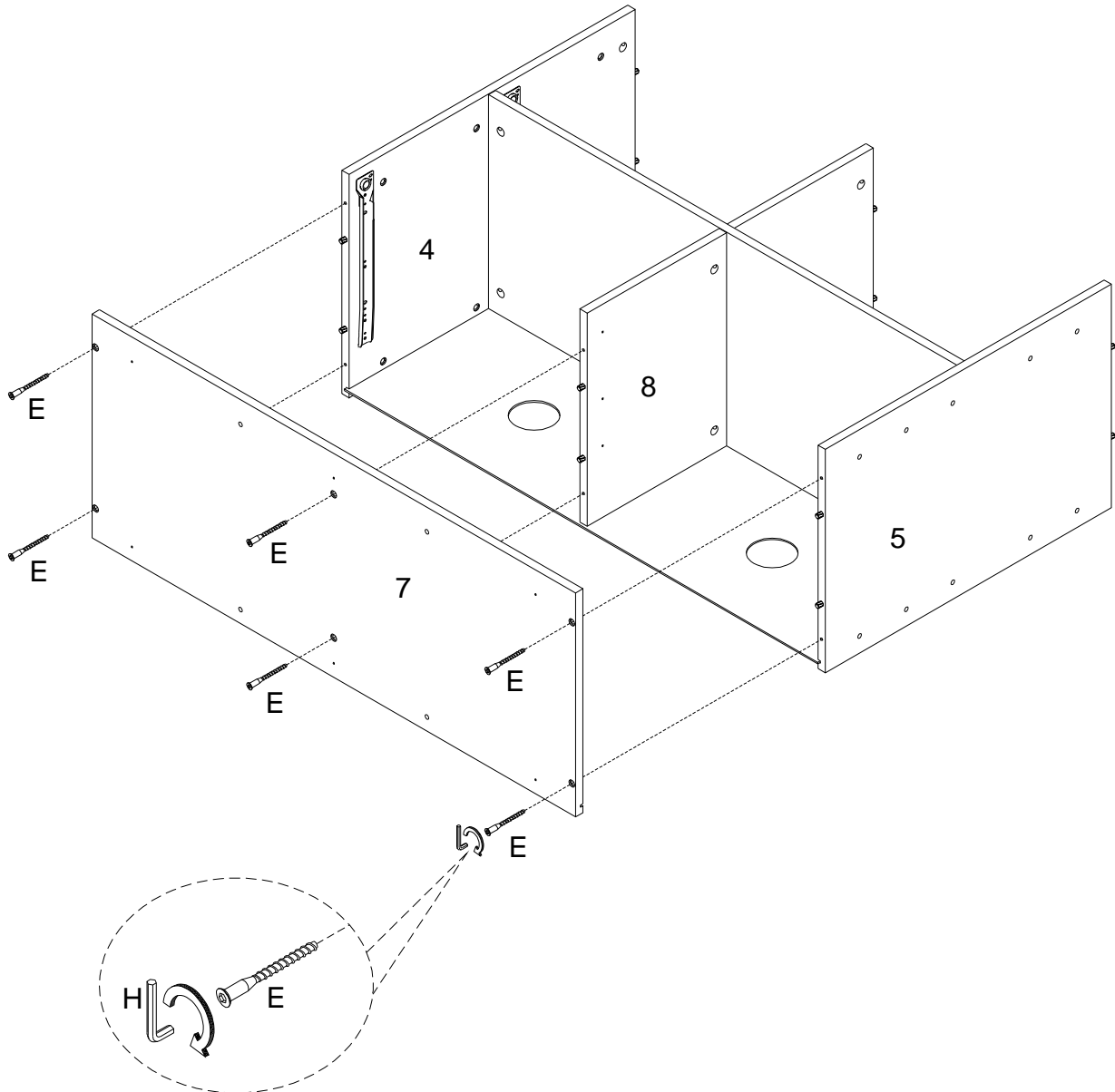

Step 10

Insert Wooden dowels (A) into each Cabinet Trim Panel (9).

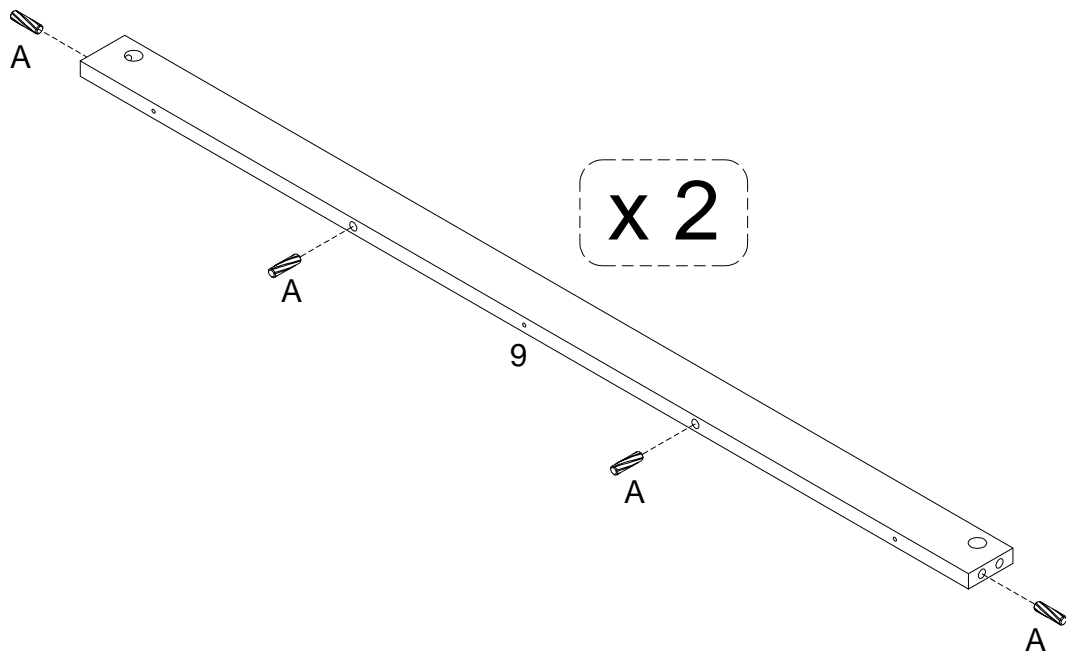

Step 11

Attach the Cabinet Trim Panels (9) to the Bottom Cabinet Panel (7) using the (P) Screws.

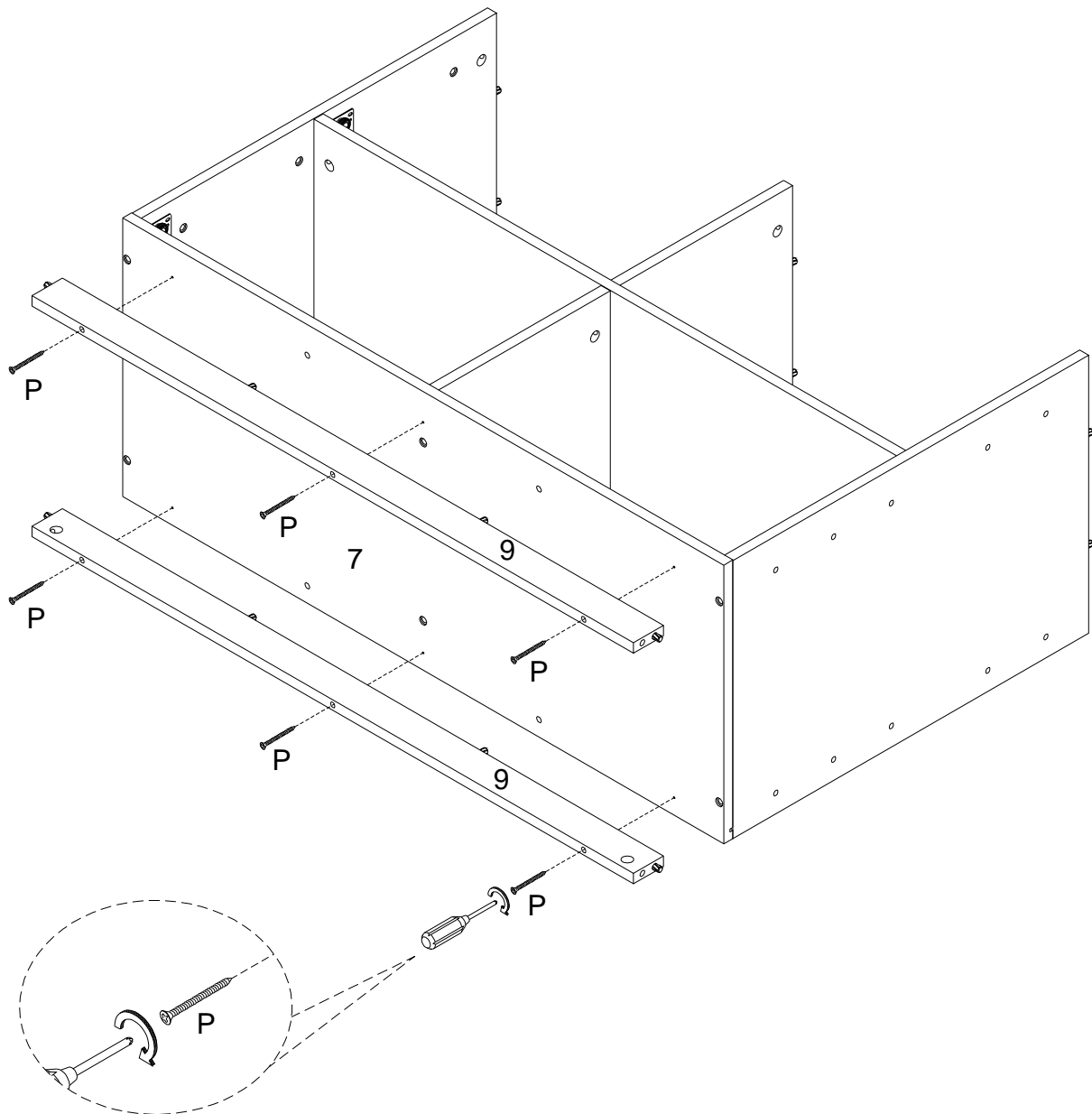

Step 12

Insert Wooden dowels (A) into the Left Cabinet Foot Frame (2) and the Right Cabinet Foot Frame (3). Then, screw Cam bolts (B) into each piece.

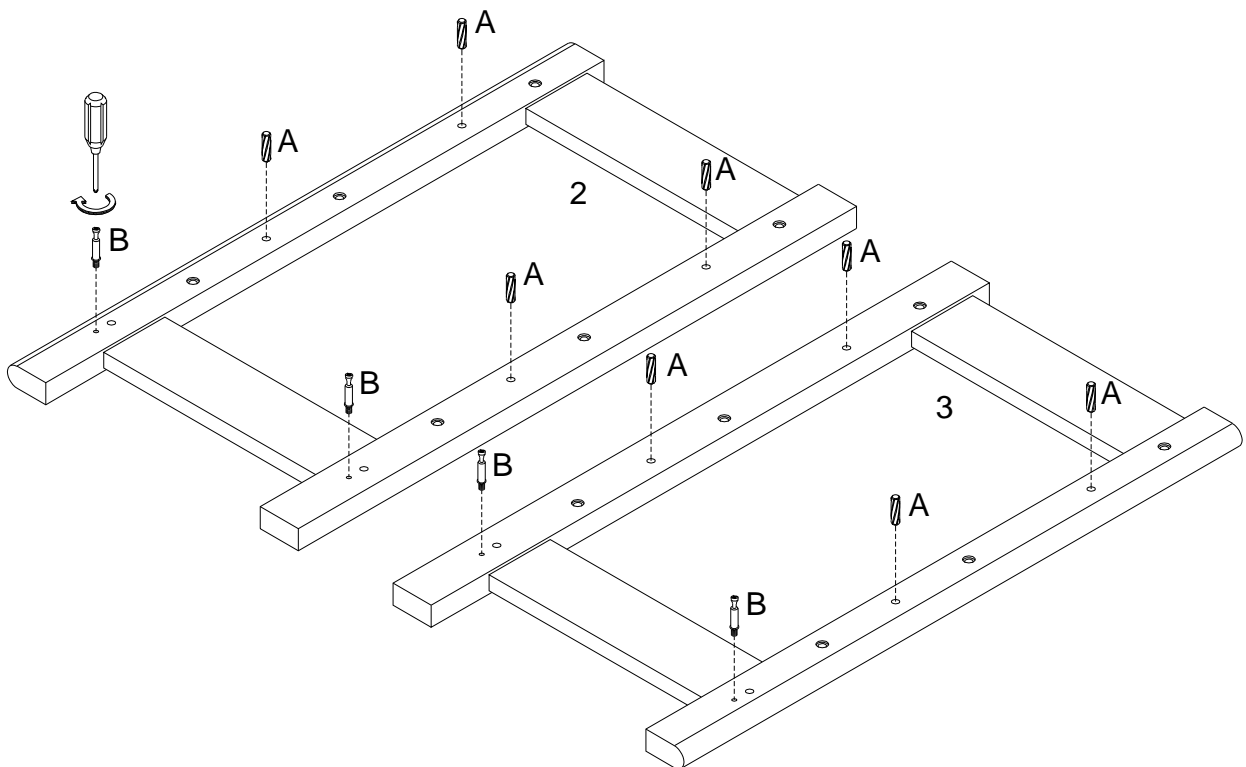

Step 13

Secure the Left Cabinet Foot Frame (2) to the Left side of the unit using the (G) Bolts. Tighten with the Hex key. Make sure to also insert the Cam locks (C) and tighten with a screwdriver.

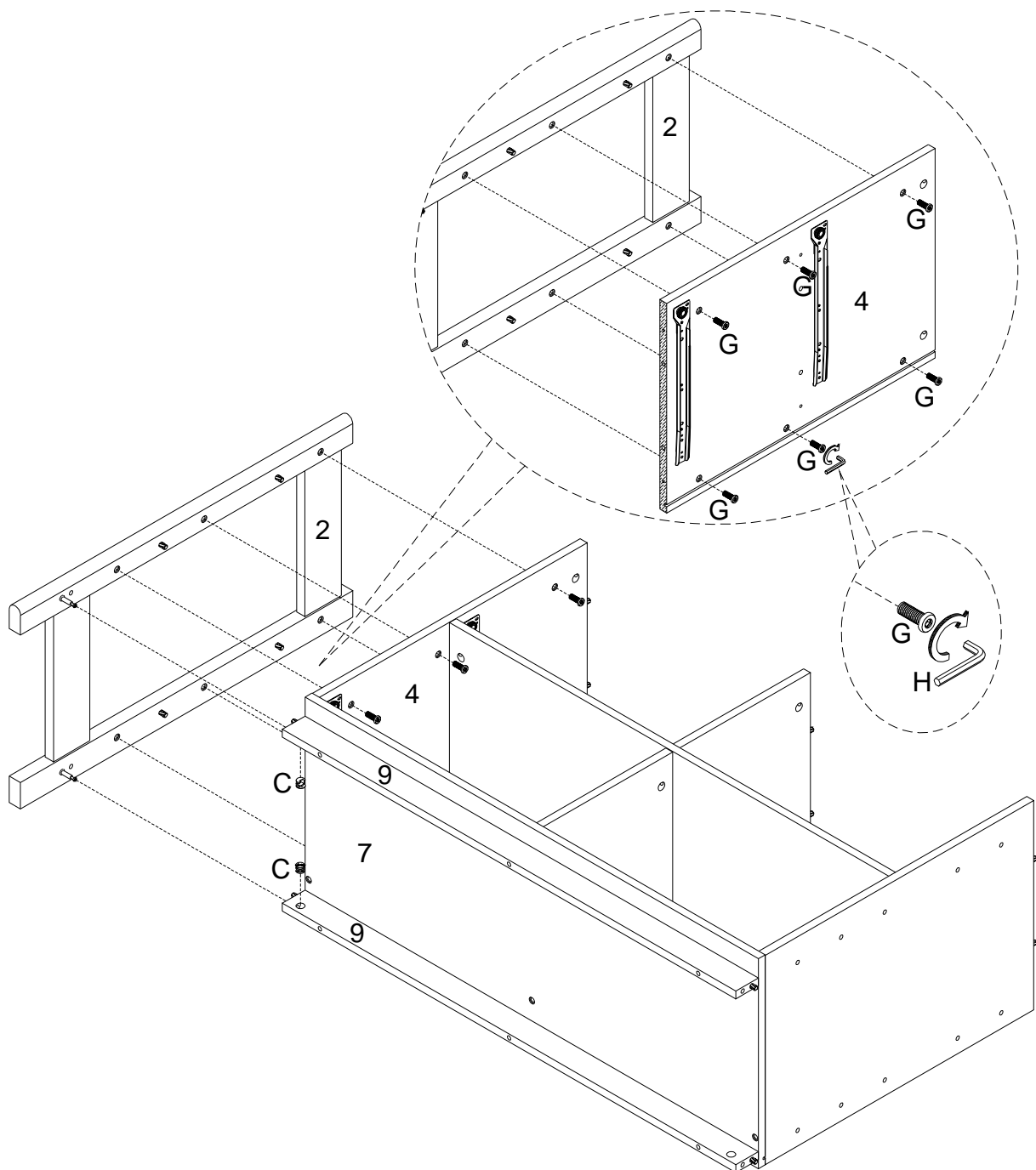

Step 14

Now, repeat that process for the other side! Secure the Right Cabinet Foot Frame (3) to the right side of the unit using the (G) Bolts. Tighten with the Hex key. Make sure to also insert the Cam locks (C) and tighten with a screwdriver.

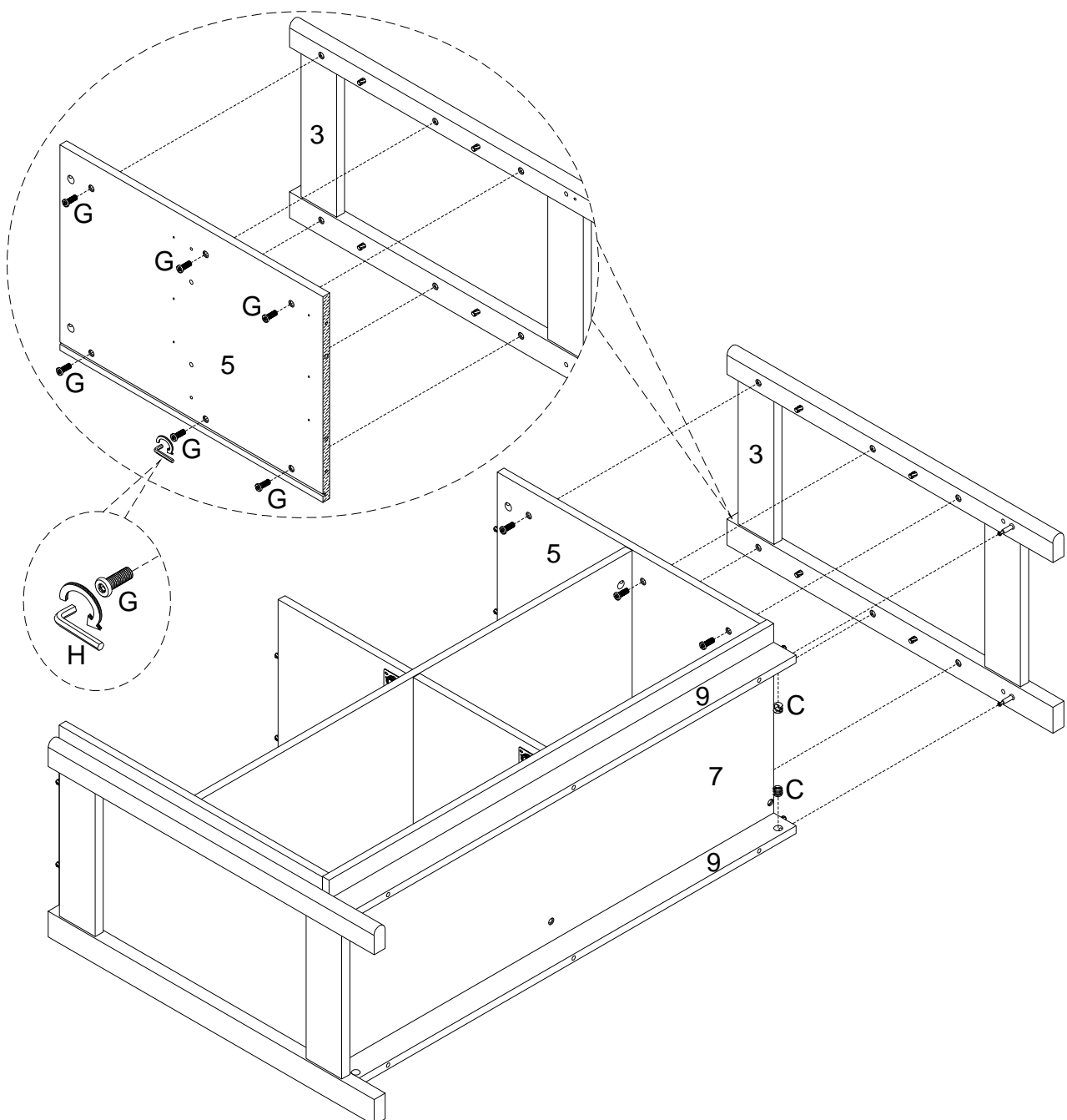

Step 15

Slide the other Cabinet Back Panel (10) into place using the grooves as a guide.

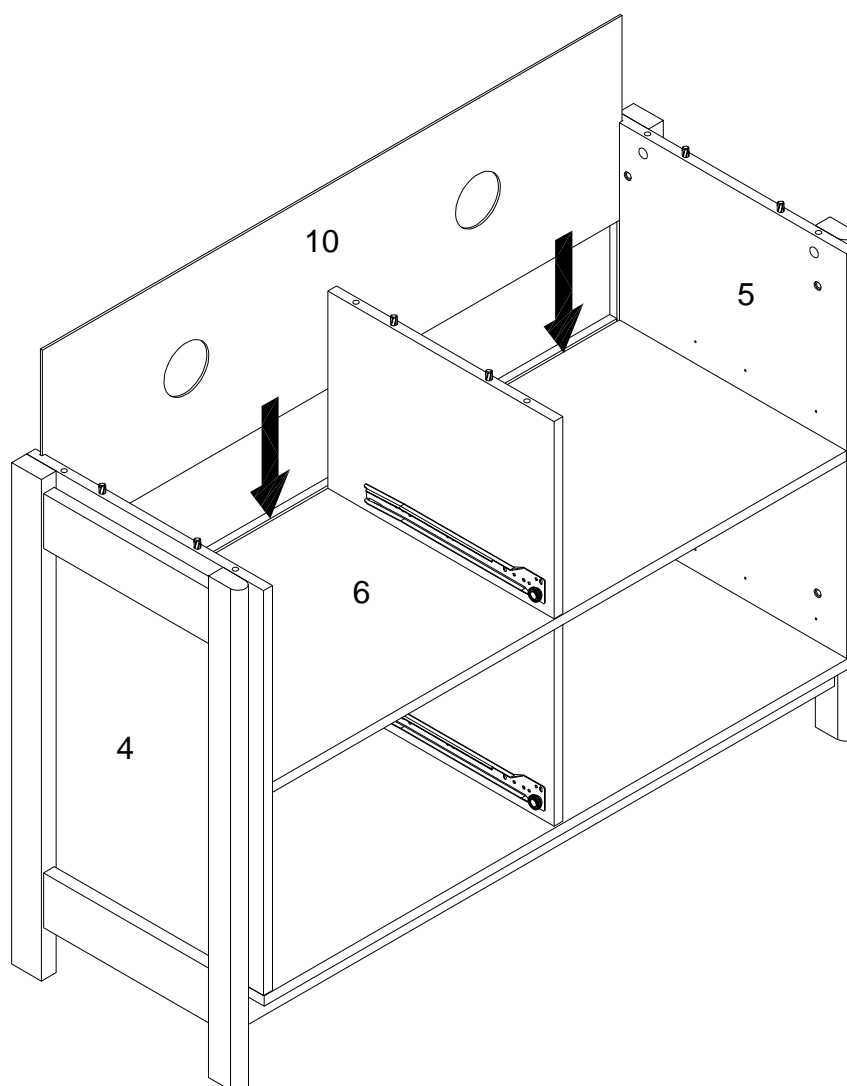

Step 16

Screw Cam bolts (B) into the Top Cabinet Panel (1).

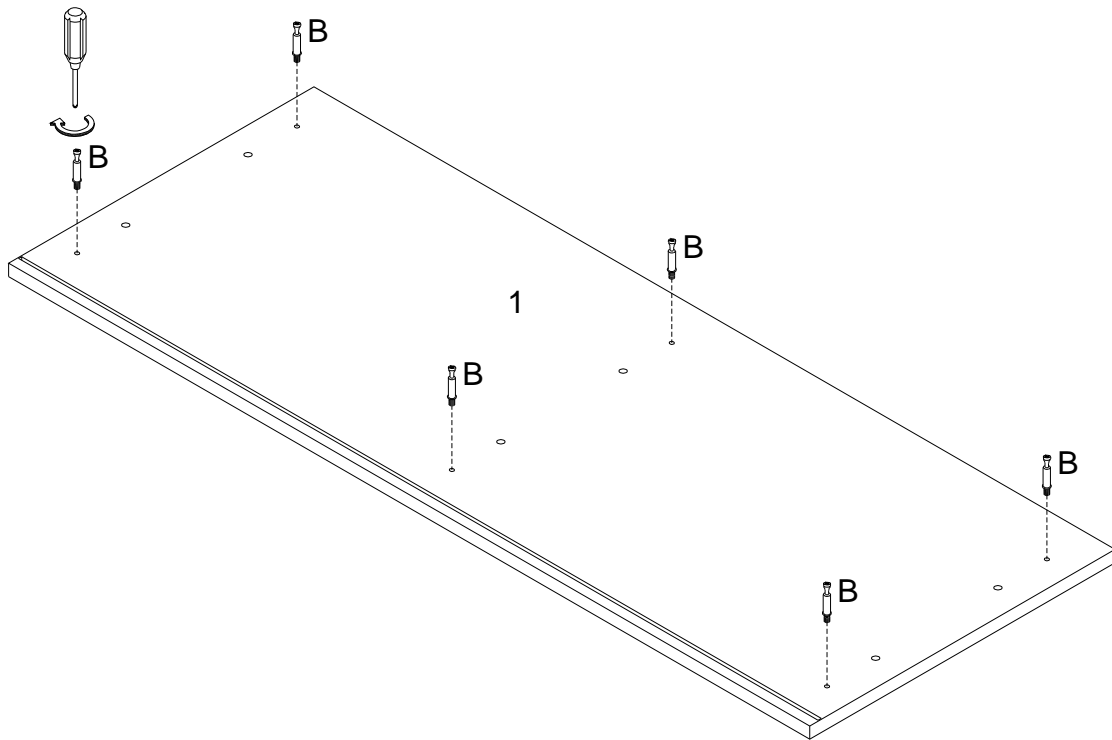

Step 17

Attach the Top Cabinet Panel (1) to the rest of the unit. Secure with Cam locks (C) and tighten with a screwdriver.

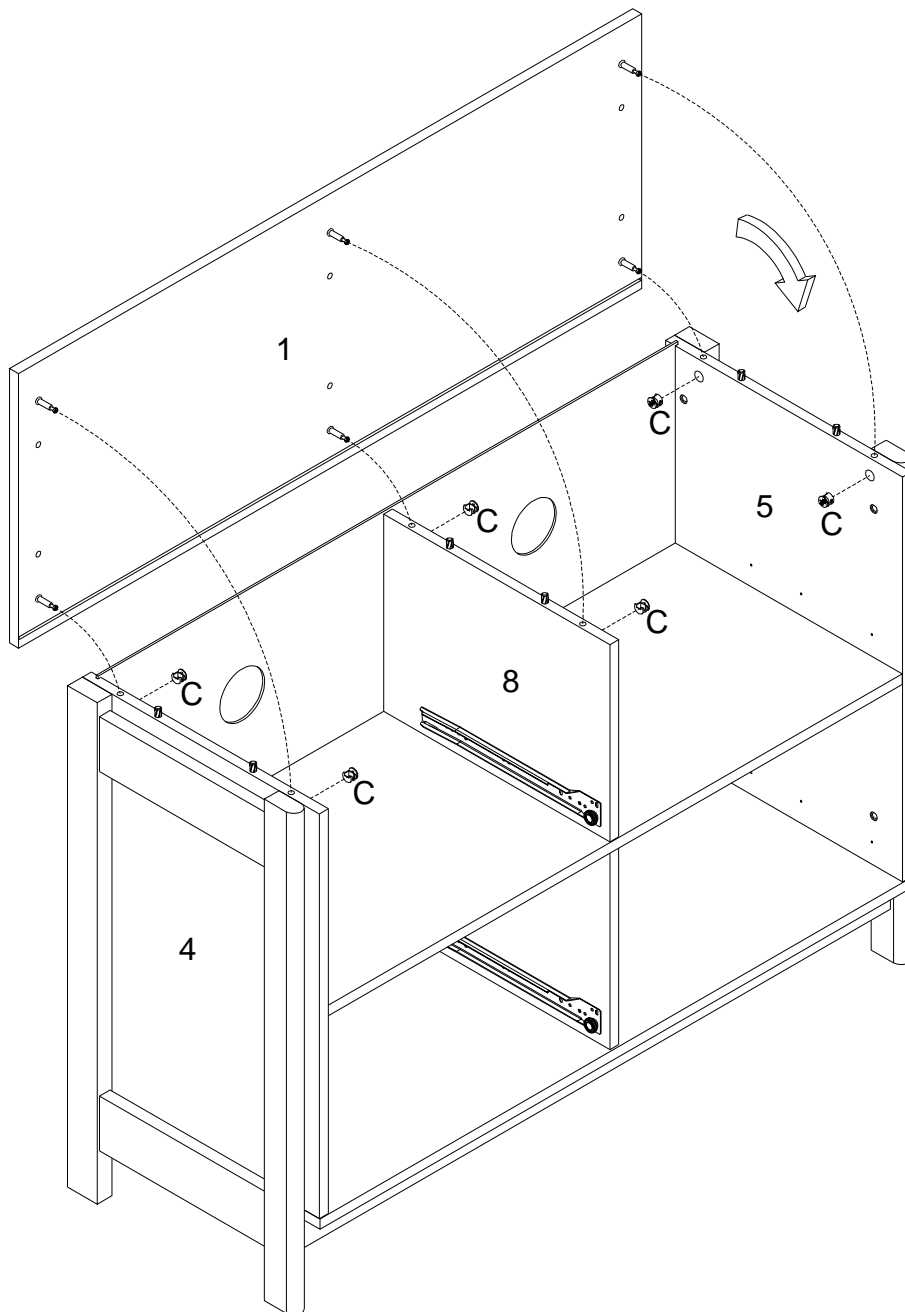

Step 18

Fit the Plastic wedges (Q) in between the Back Panels (10) and the rest of the unit. Secure the Plastic wedges (Q) with (R) Screws.

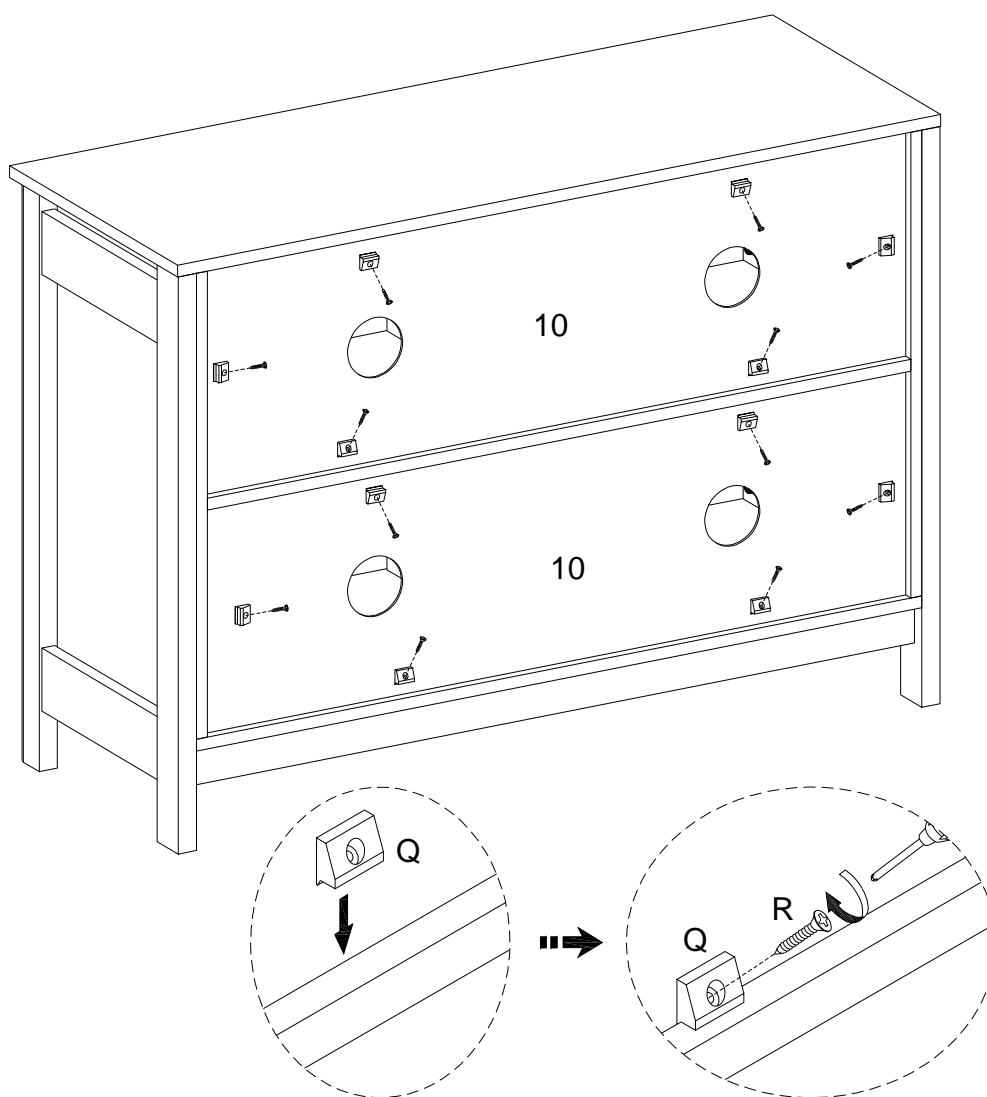

Step 19

Secure the Drawer Left Panel (12) and the Drawer Right Panel (13) to the Drawer Back Panel (14) using the (J) Screws. Do this for both drawers.

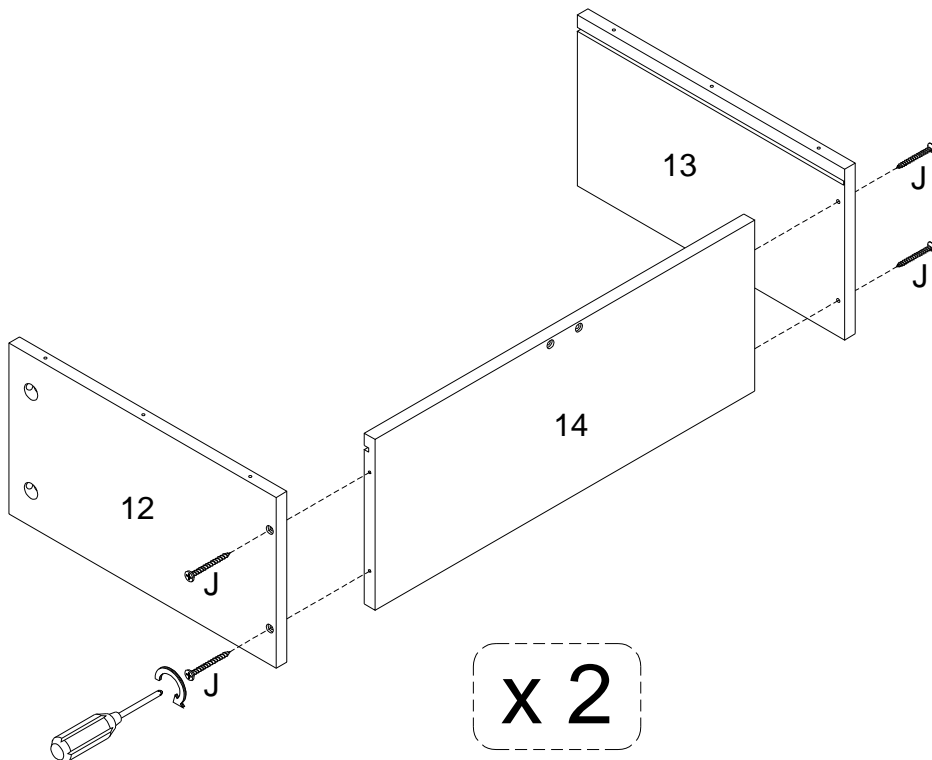

Step 20

Now, slide the Drawer Bottom (16) into place using the grooves as a guide. Do this for both drawers.

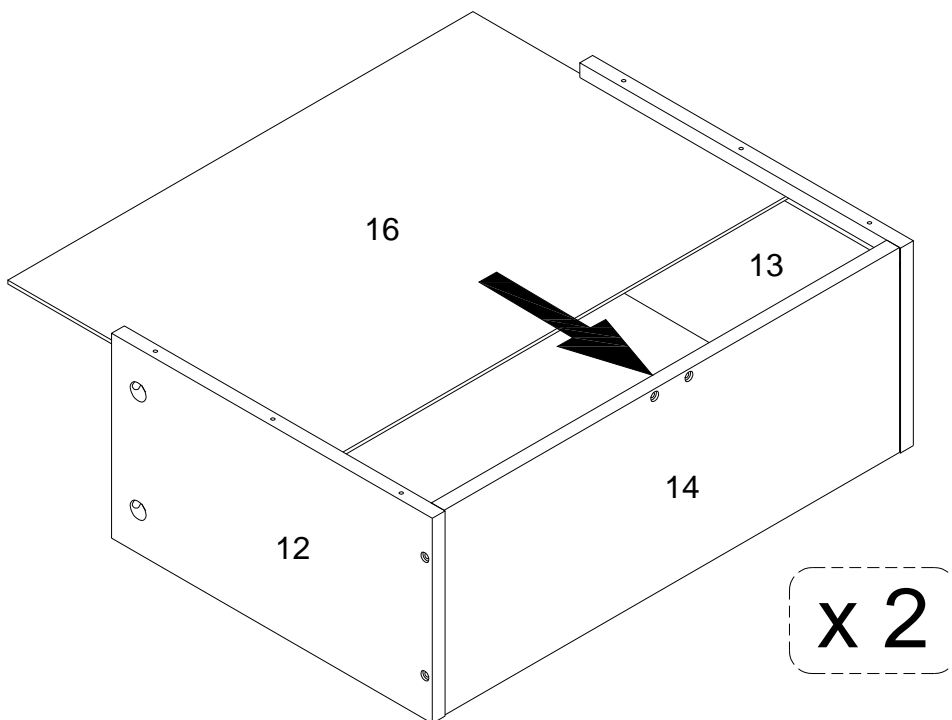

Step 21

Fasten the Drawer Support (15) to the Drawer Back Panel (14) using the (J) Screws.

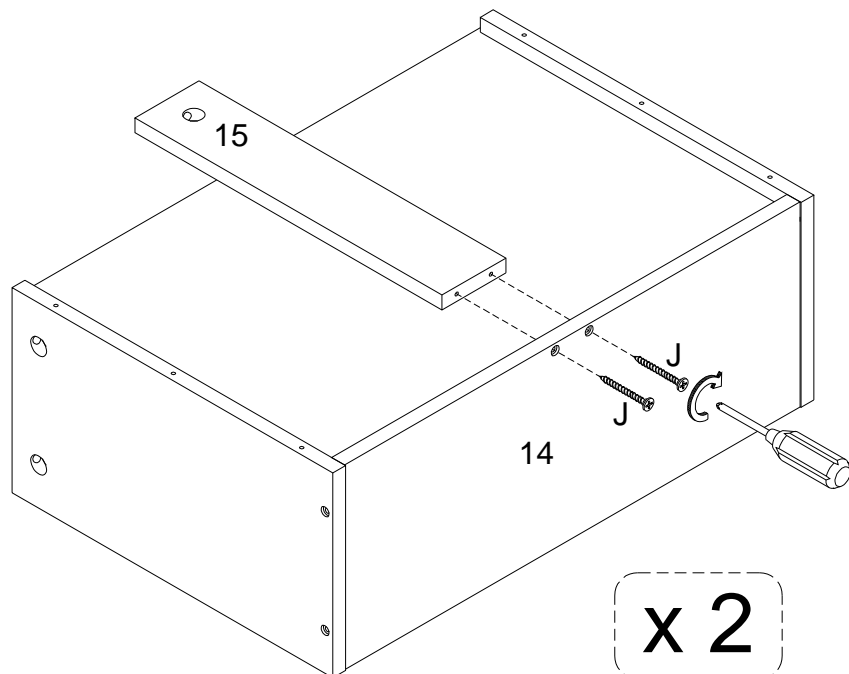

Step 22

Screw Cam bolts (B) into each Drawer Front (11). Then, attach the Drawer pull (K) to each Drawer Front (11) using the (L) Screws.

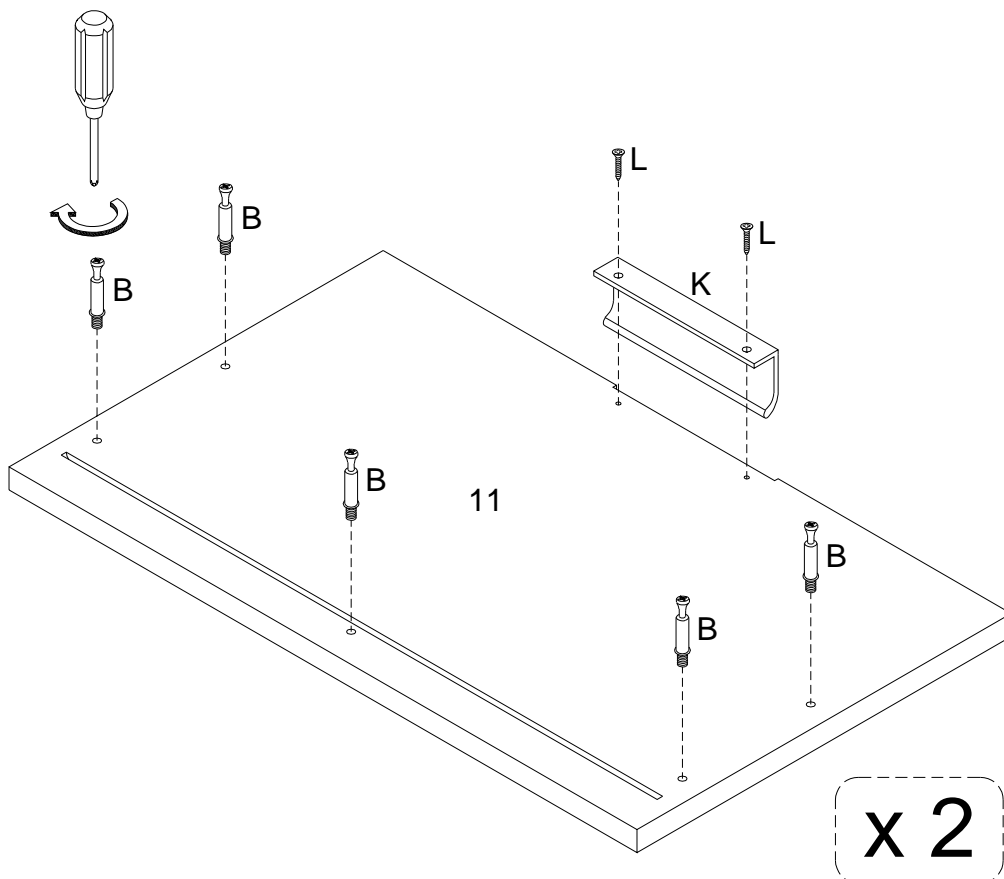

Step 23

Secure the Drawer Front (11) to the Drawer using Cam locks (D). Tighten with a screwdriver. Do this for both drawers.

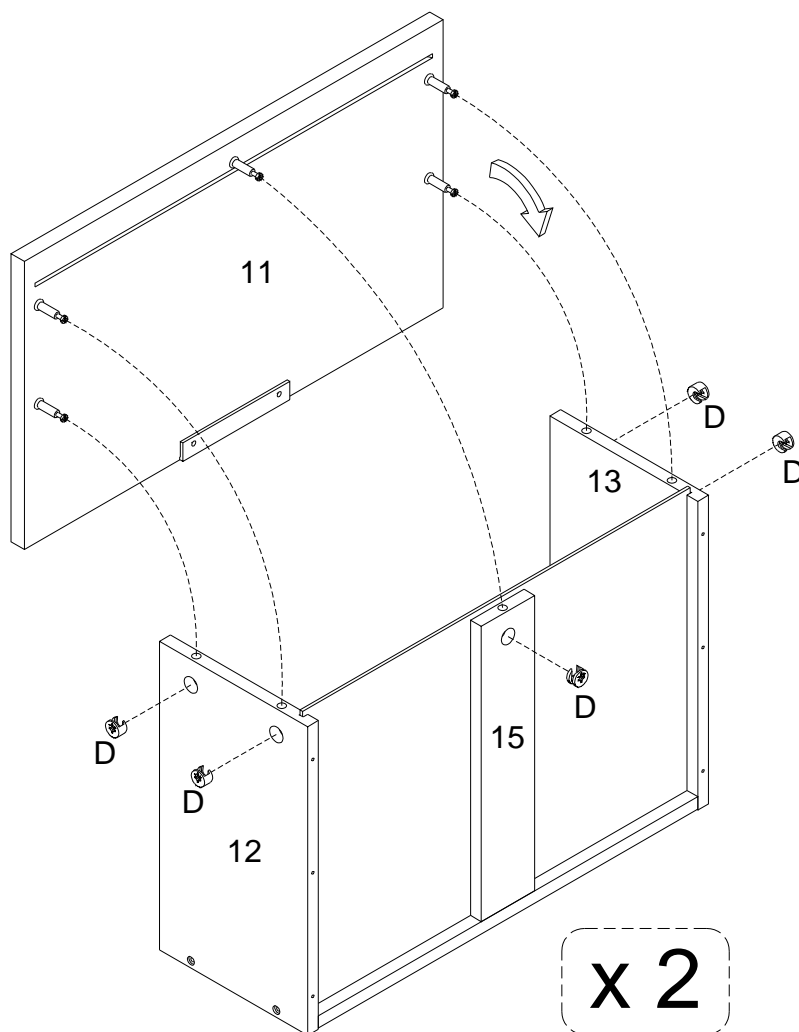

Step 24

Attach the Drawer member side of the Drawer Glides (S) and (T) to the drawer using the (L) Screws.

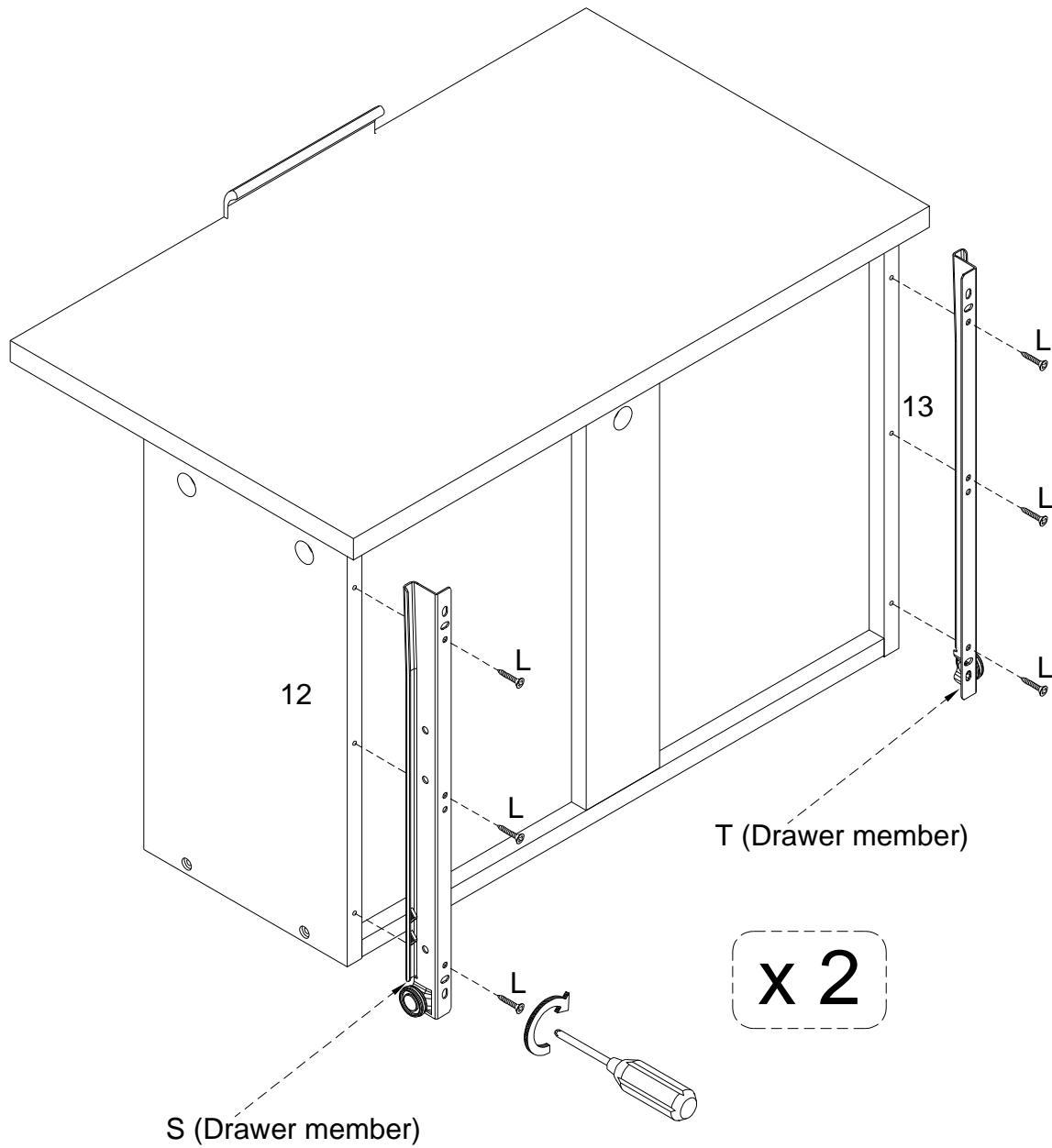

Step 25

Ensure a clean finish by covering each Cam lock with the provided Stickers (U).

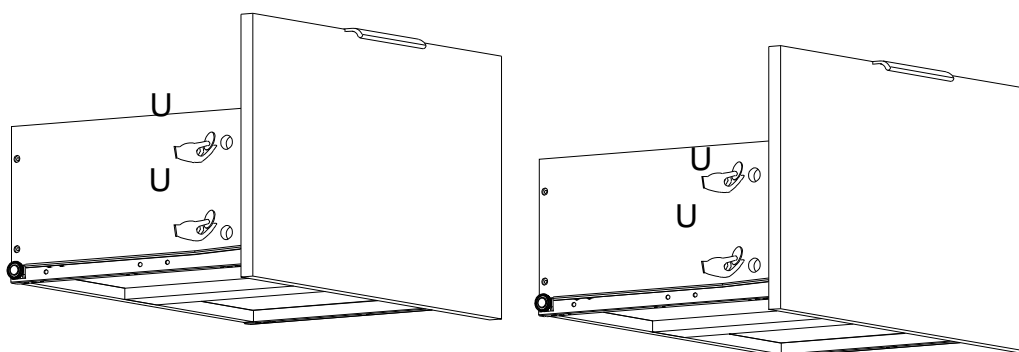
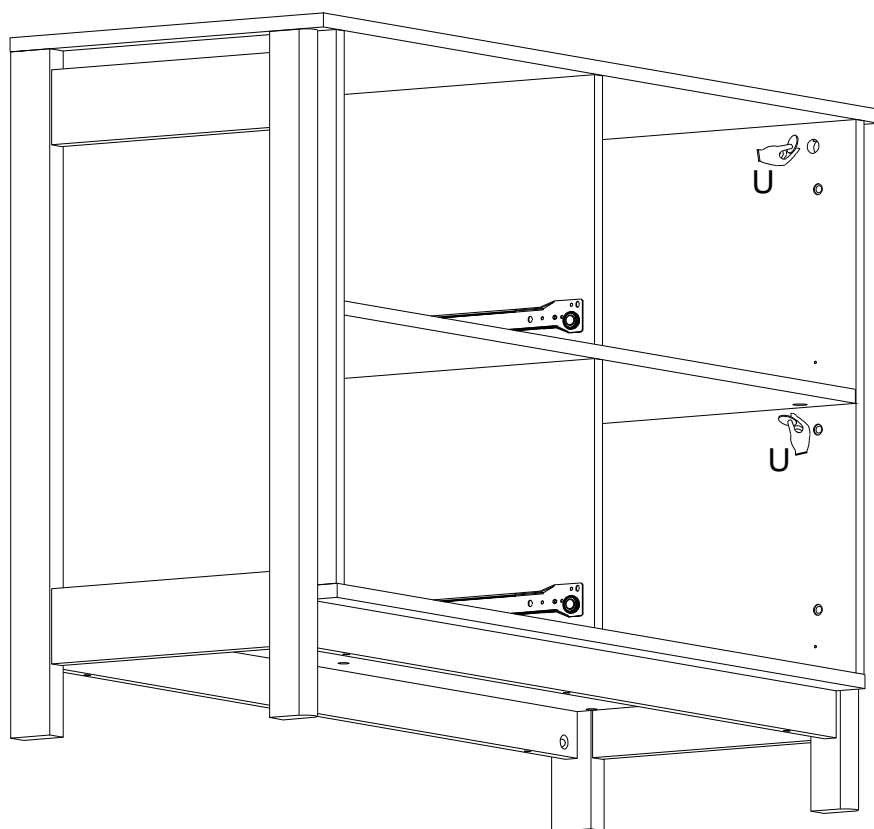

Step 26

Insert each drawer into the cabinet.

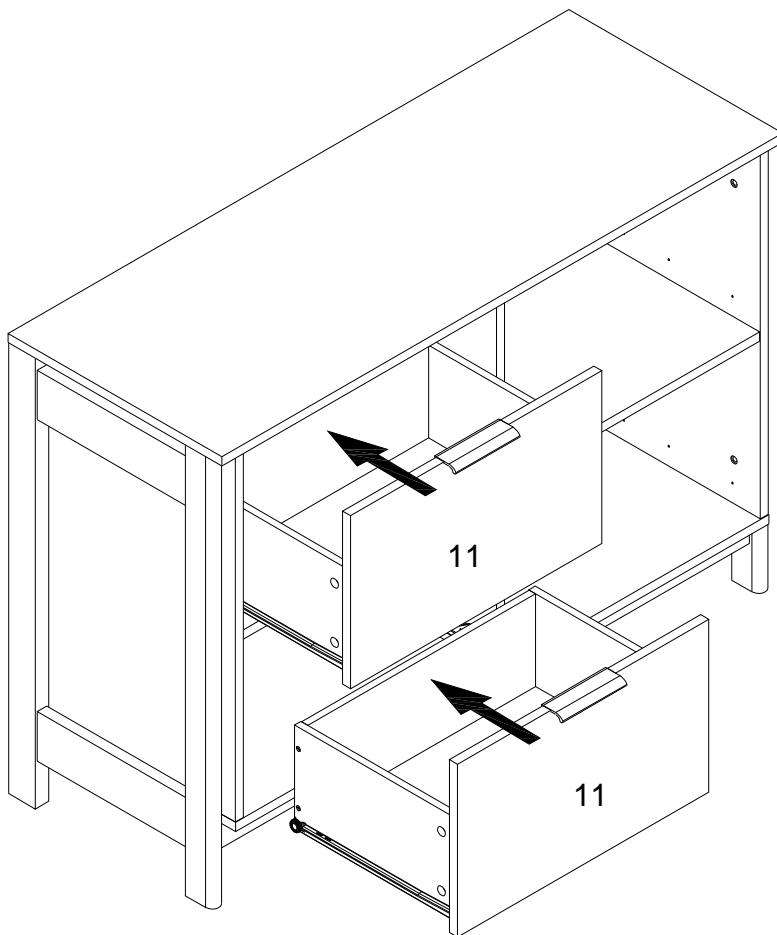

Cabinet member

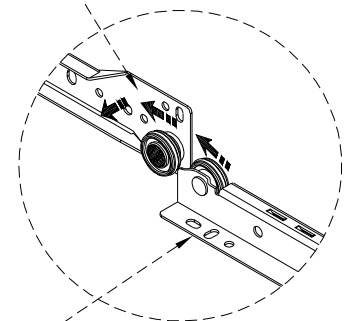

Drawer member

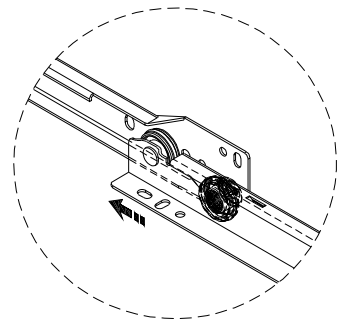

Step 27

Let's move on to the desk! Screw Cam bolts (B) into the Desktop (17).

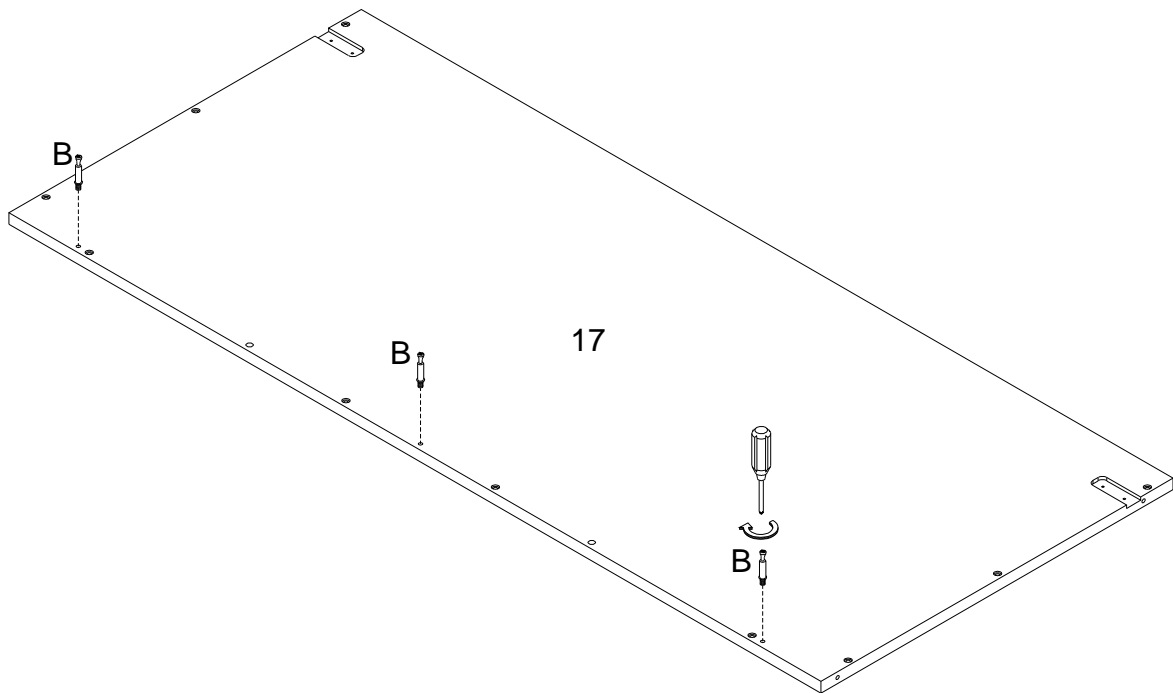

Step 28

Attach the Desk Left Trim Panel (18) and the Desk Right Trim Panel (19) to the Desk Back Trim Panel (20) using the (J) Screws.

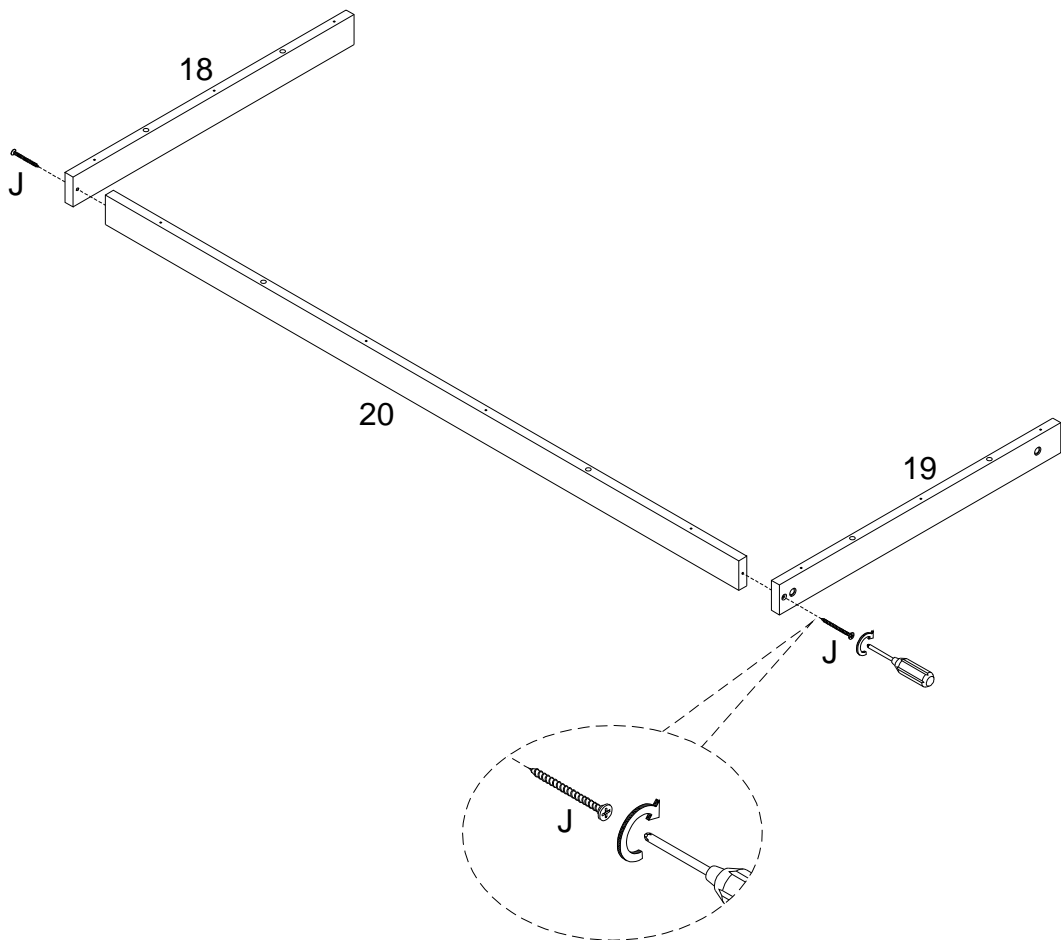

Step 29

Insert Wooden dowels (A) into the Trim Panels (18), (19), and (20).

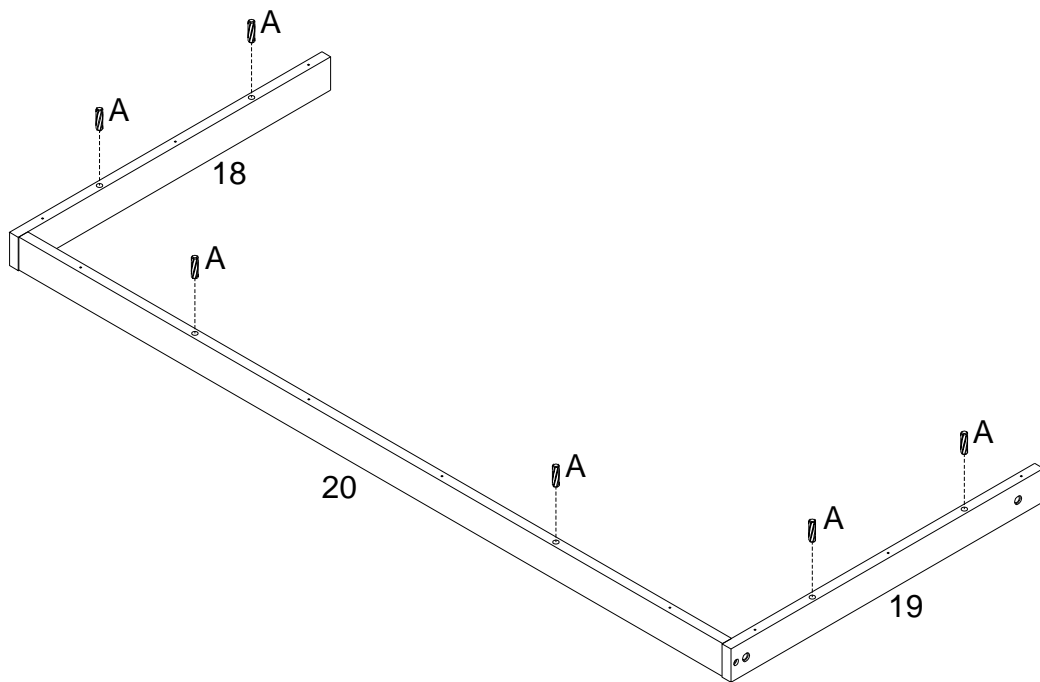

Step 30

Secure the Desktop (17) to the Trim Panels using the (J) Screws.

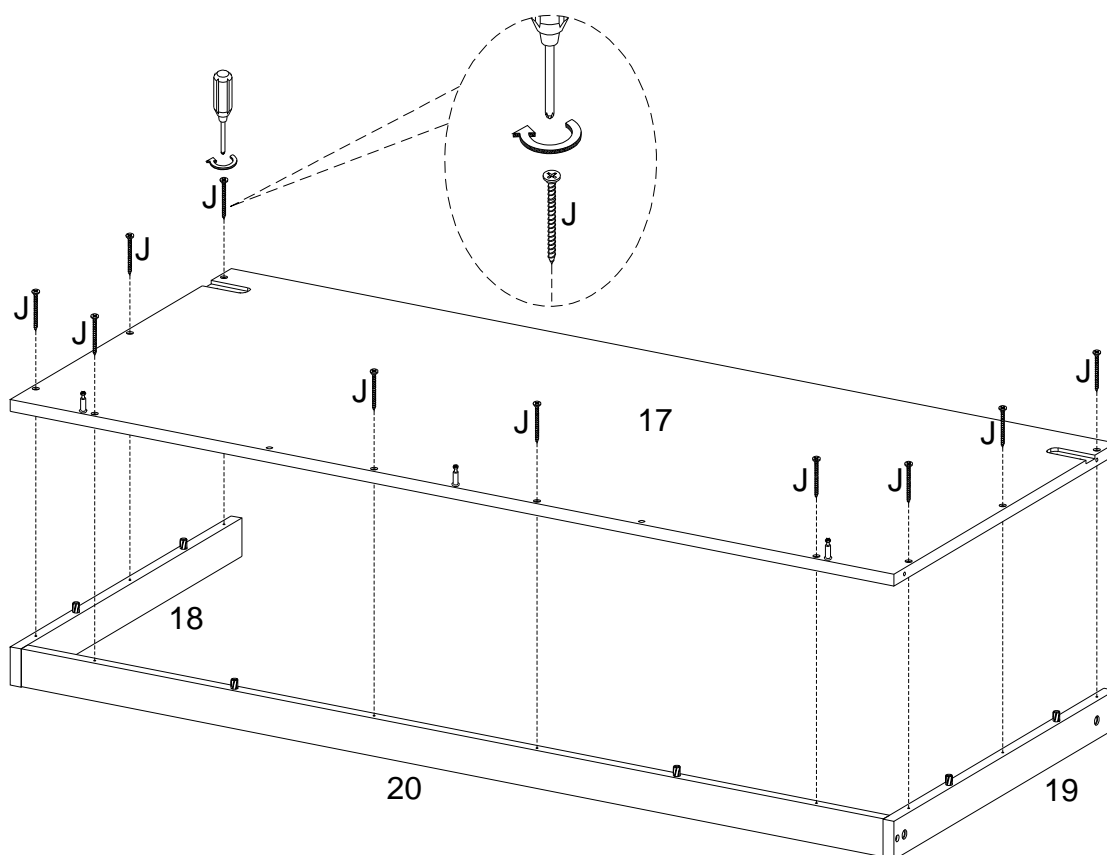

Step 31

Insert Wooden dowels (A) into the Back Desk Panel (23) and the Desk Bottom Trim Panel (24).

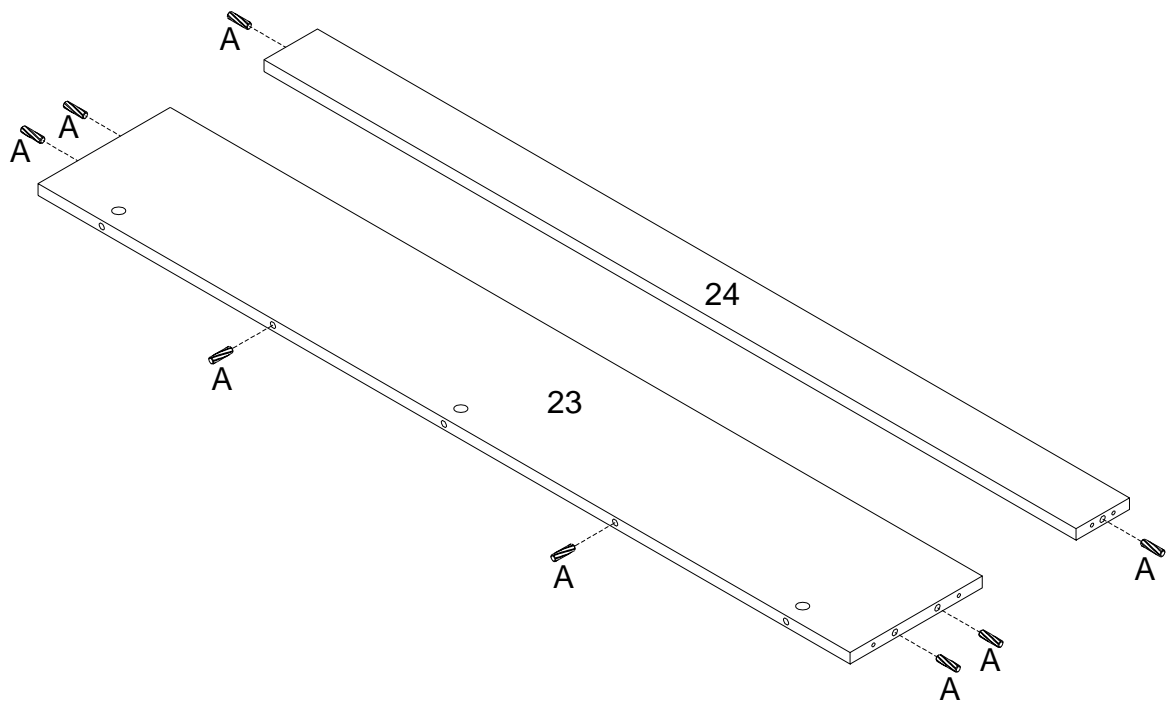

Step 32

Secure the Back Desk Panel (23) to the Desktop (17) using Cam locks (C). Tighten with a screwdriver.

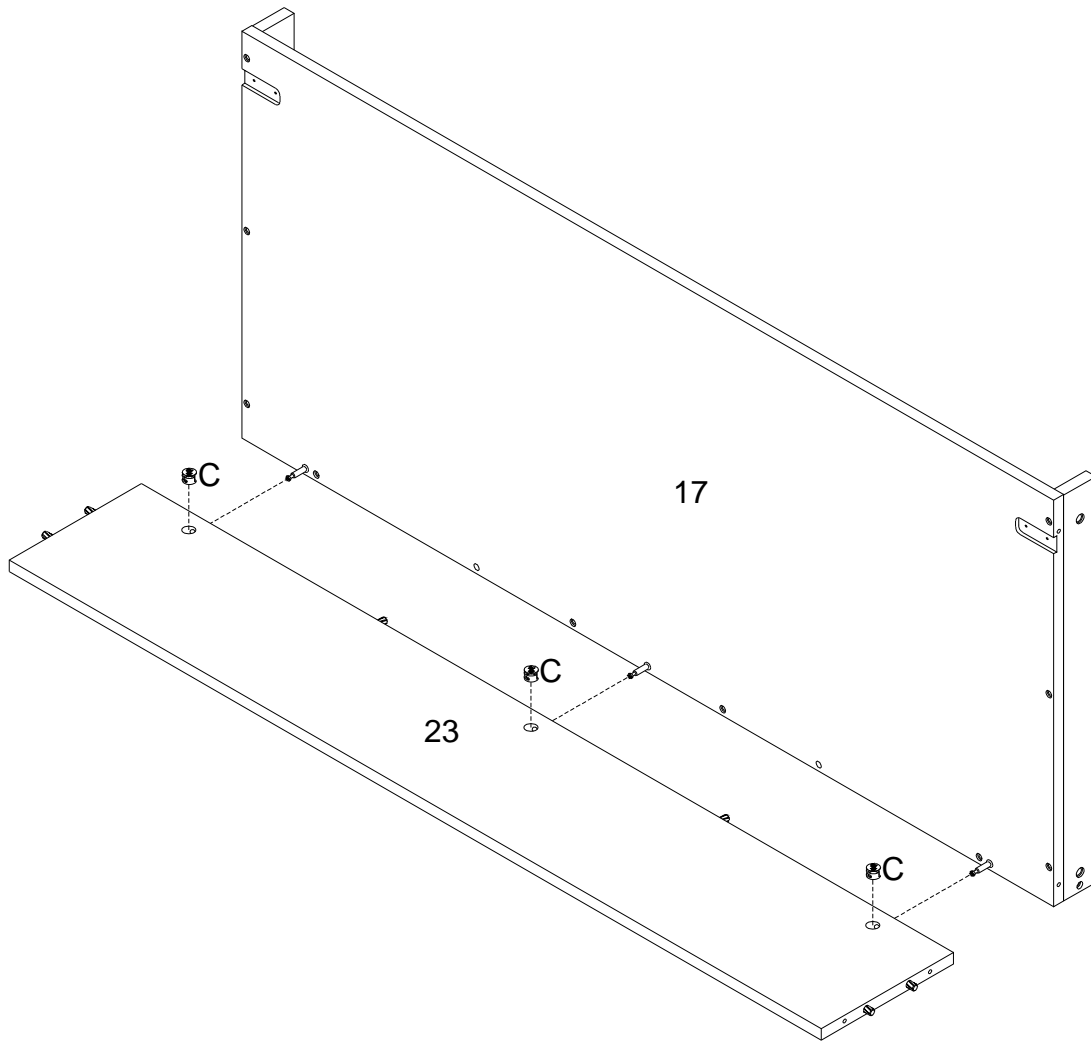

Step 33

Attach the Desk Bottom Trim Panel (24), the Back Desk Panel (23), and the Desktop (17) to the Right Desk Foot Frame (22) using the (F) and (E) Bolts. Tighten with the Hex key.

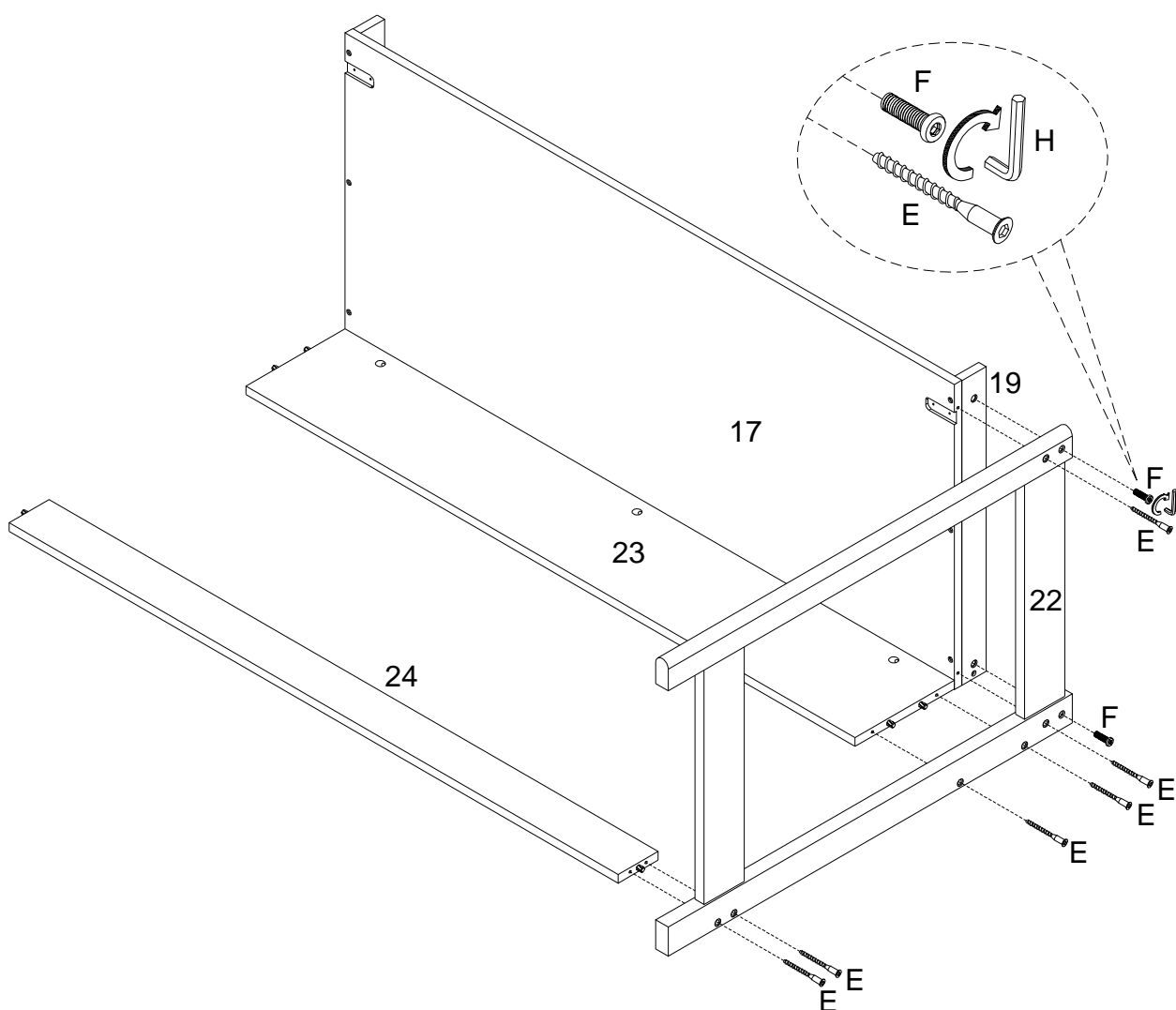

Step 34

Now repeat that for the other side! Attach the Desk Bottom Trim Panel (24), the Back Desk Panel (23), and the Desktop (17) to the Left Desk Foot Frame (21) using the (F) and (E) Bolts. Tighten with the Hex key.

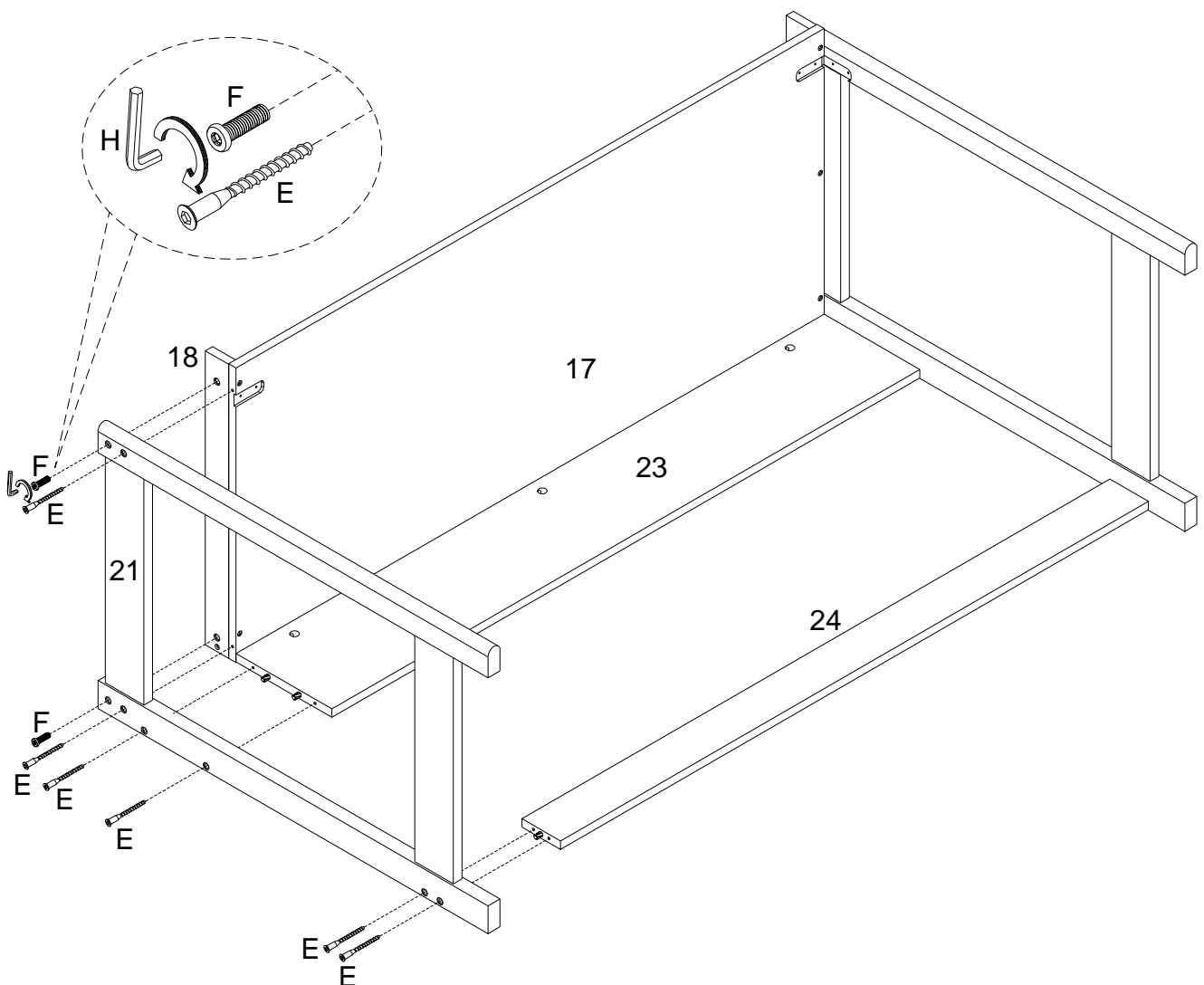

Step 35

Secure the L-shaped bracket (M) to the Desktop (17) and the Left Desk Foot Frame (21) using the (N) Screws.

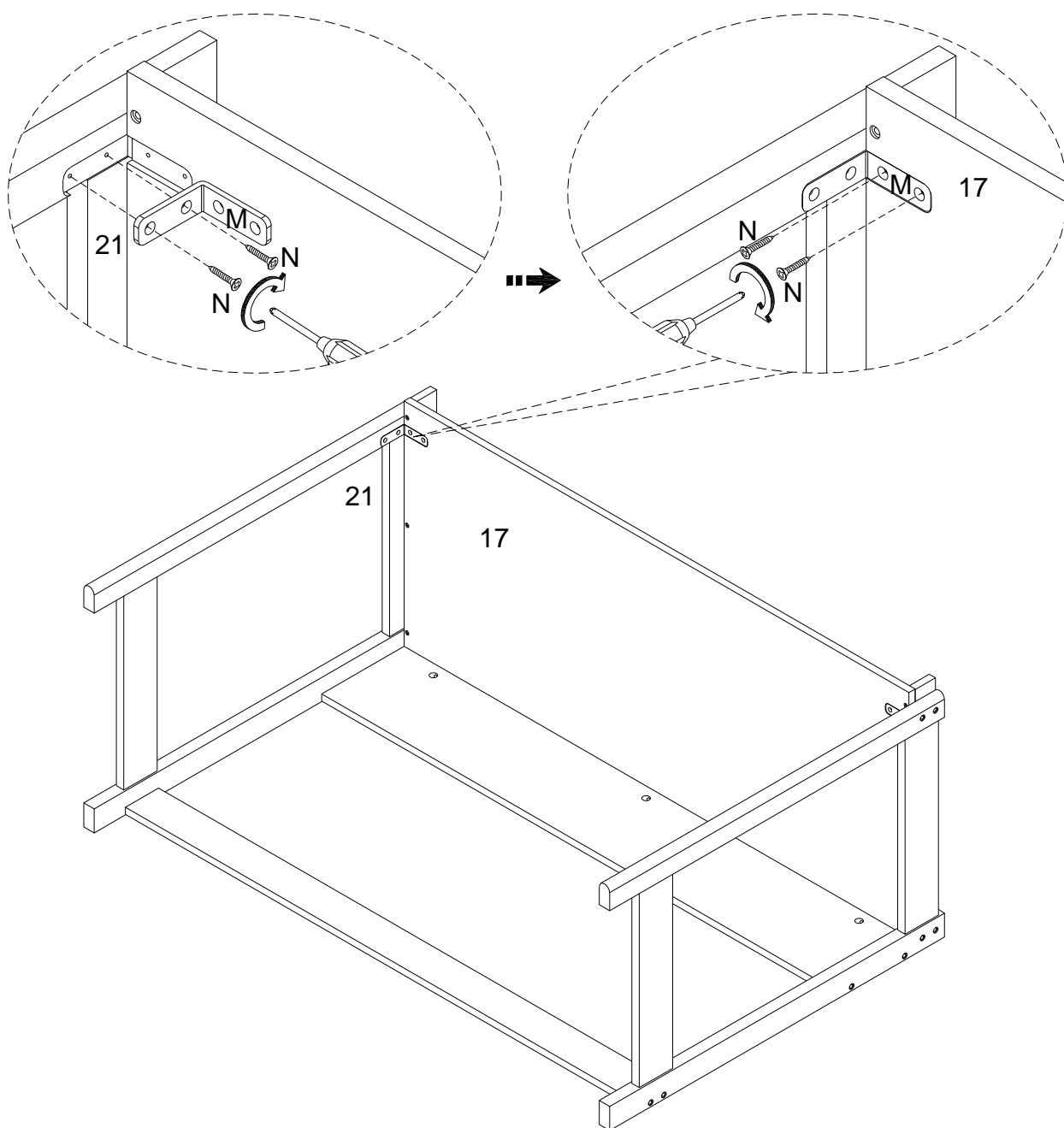

Step 36

Repeat that for the other side! Secure the L-shaped bracket (M) to the Desktop (17) and the Right Desk Foot Frame (22) using the (N) Screws.

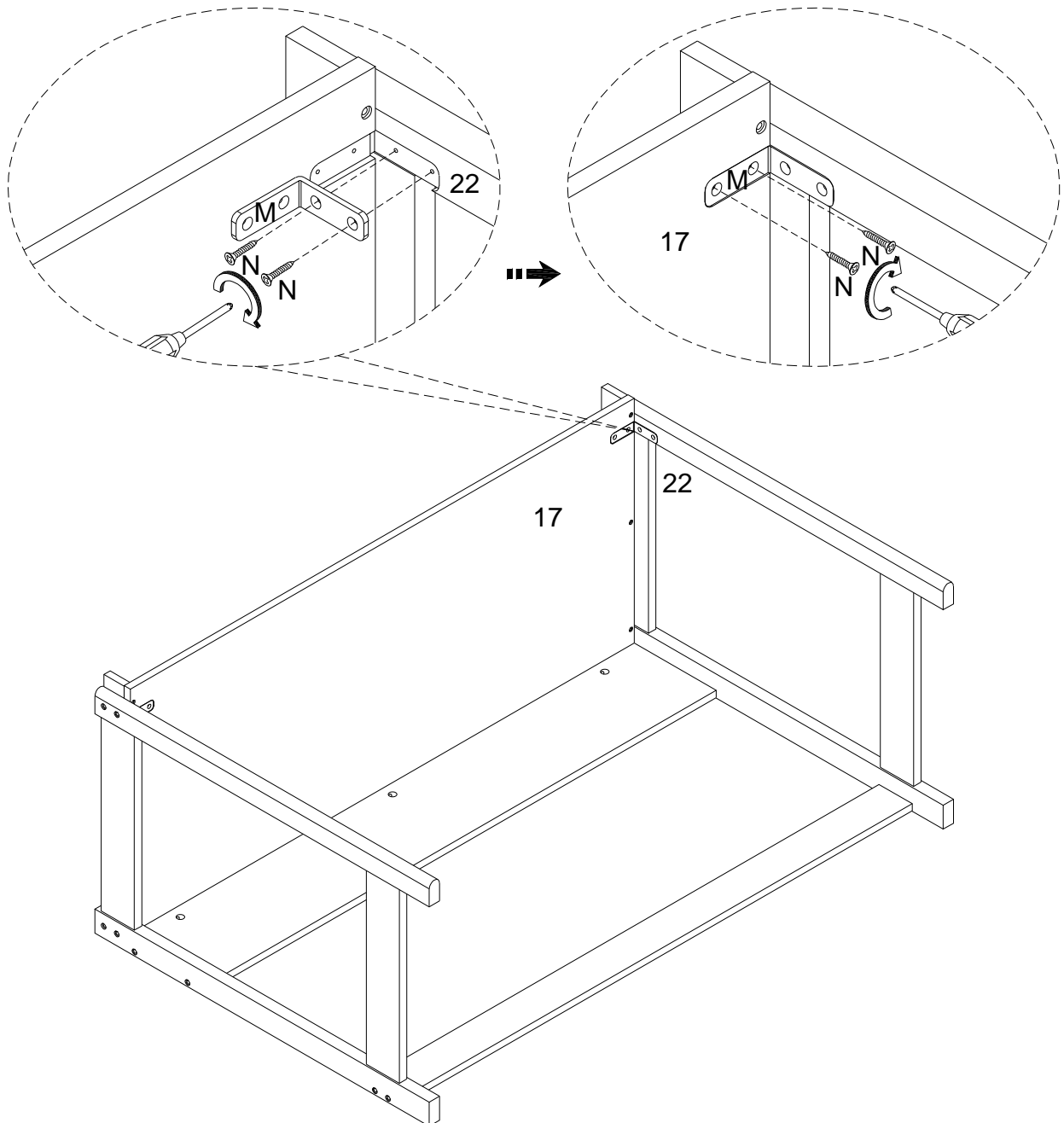

Step 37

Ensure a clean finish by covering each Cam lock with the provided Stickers (U).

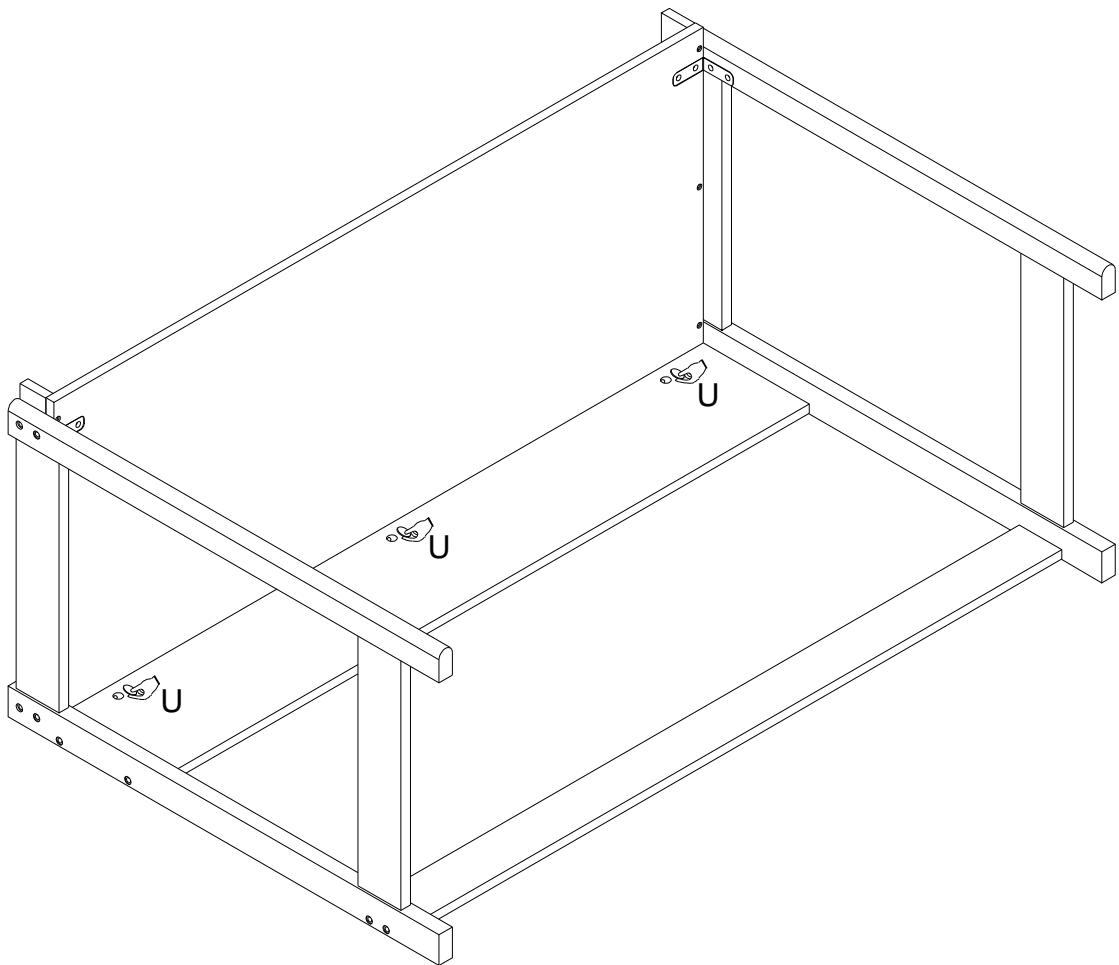

Step 38

Slide your finished desk on top of your finished cabinet and you're done!

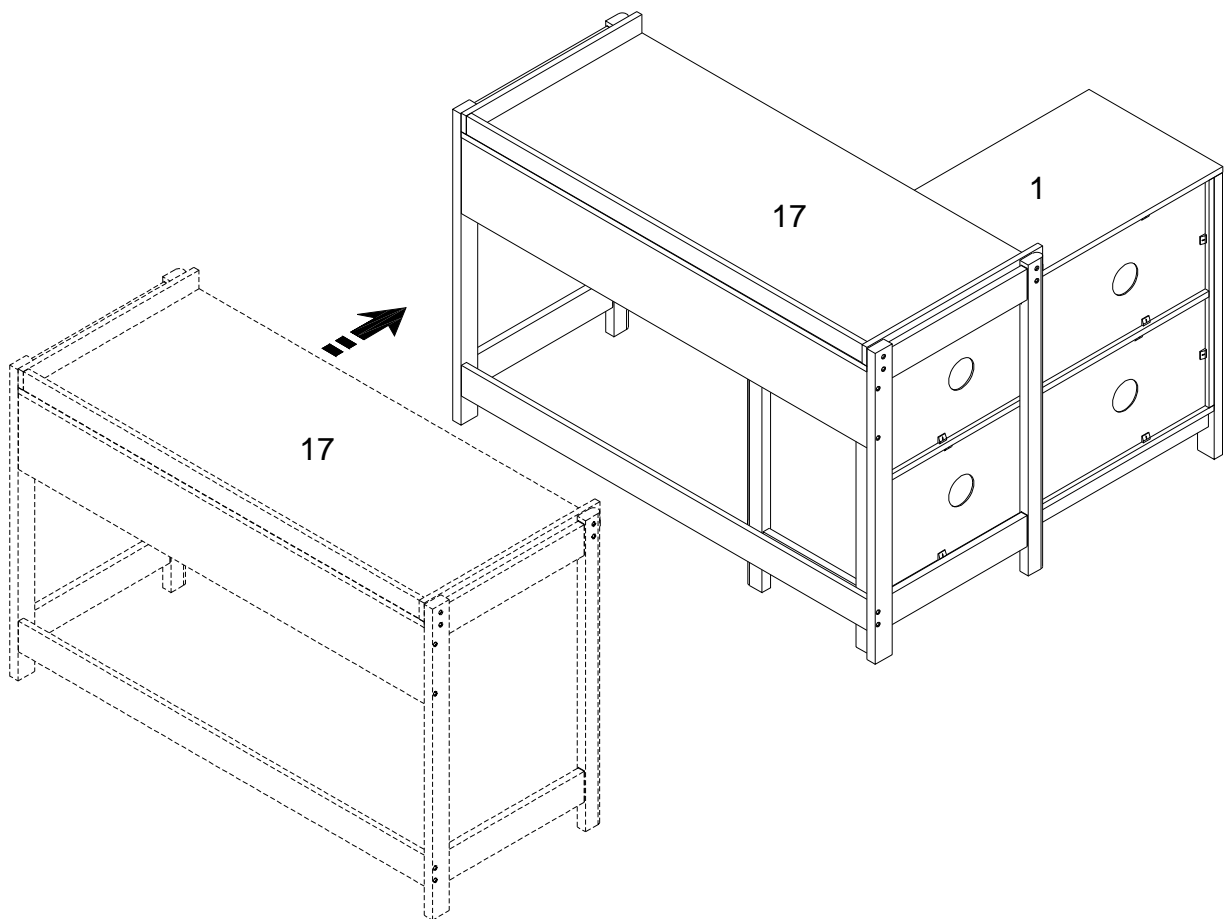

Final Assembly

Option A

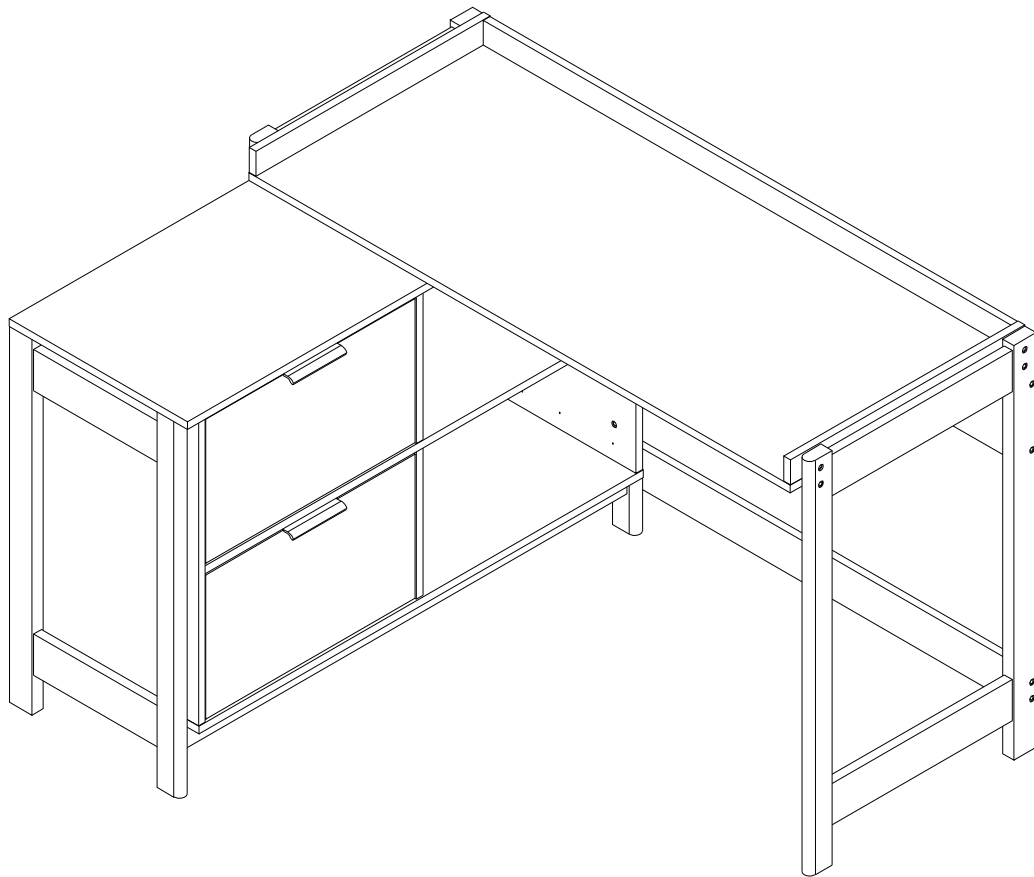

Congratulations on your new piece of furniture!

**We would love to hear about it and see it.
Please leave us a review or post a picture with
#mywalkerredisonhome**

Assembling furniture can be tricky sometimes.

Our customer service team, located in Utah, is here for product information, help assembling a product, or for any other customer support issue

Call us at 801-433-3008

Email us at service@walkeredison.com

Visit our Customer Service website at walkeredison.com/pages/customer-service

We are available to help Monday -Thursday 8am-5pm, Friday 8am-3pm MST

For details on Assembly Videos, Assembly Instructions, Replacement Parts, and Customer service,
SCAN HERE

