

Vivez l'expérience  
**MAAX**<sup>®</sup>  
 Enjoy the experience

**INSTALLATION INSTRUCTIONS**  
**GUIDE D'INSTALLATION**  
**GUÍA DE INSTALACIÓN**

FOR RIGHT AND LEFT SIDE DOOR INSTALLATION  
 (LEFT SIDE SHOWN)  
 POUR INSTALLATION DE PORTE CÔTÉ DROIT ET GAUCHE  
 (CÔTÉ GAUCHE ILLUSTRÉ)  
 PARA LA INSTALACIÓN DE LA PUERTA DEL LADO DERECHO E IZQUIERDO  
 (SE MUESTRA INSTALACIÓN AL LADO IZQUIERDO)

**MODEL • MODÈLE • MODELO**

**Pivot shower door**

**Porte de douche pivot**

**Puerta pivot de ducha**

**139575 • 139576 • 139577 • 139578 • 139579 • 139580**

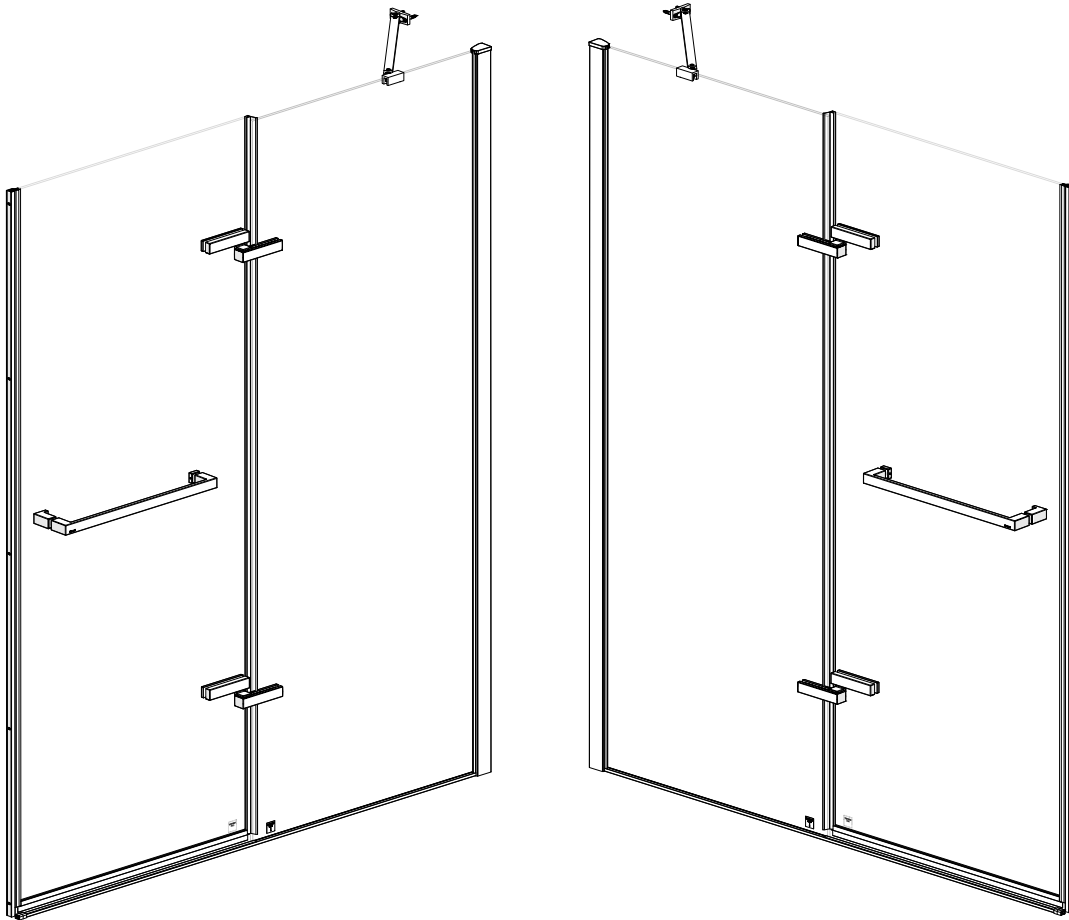

  
 Maintenance guide p.22  
 Guide d'entretien p.22  
 Guía de mantenimiento p.22

Read all instructions carefully before proceeding.

Lire attentivement toutes les instructions avant de commencer l'installation.

Leer detenidamente todas las instrucciones antes de comenzar la instalación.

**SAVE THIS GUIDE FOR FUTURE REFERENCE.**

**CONSERVER POUR UN USAGE ULTÉRIEUR.**

**CONSERVE ESTE MANUAL COMO REFERENCIA.**

**IMPORTANT** • Record the serial number  
**IMPORTANT** • Noter le numéro de série  
**IMPORTANTE** • Registre el número de serie

Serial number • Numéro de série • Número de Serie

Door \_\_\_\_\_

Return panel \_\_\_\_\_

**PARTS** | **PIÈCES** | **PIEZAS**  
 AND COMPONENTS | ET COMPOSANTES | Y COMPONENTES

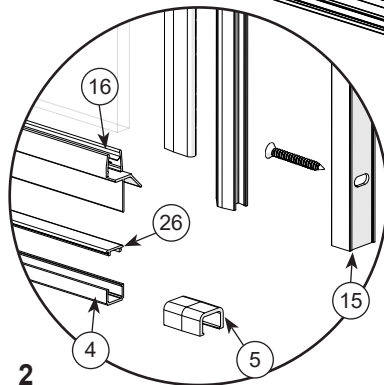
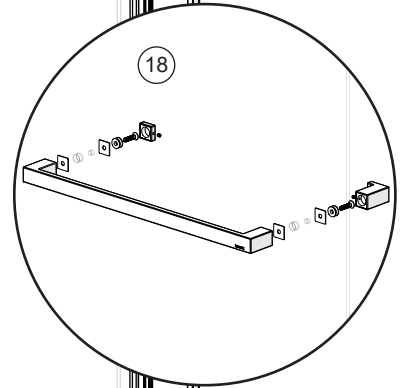
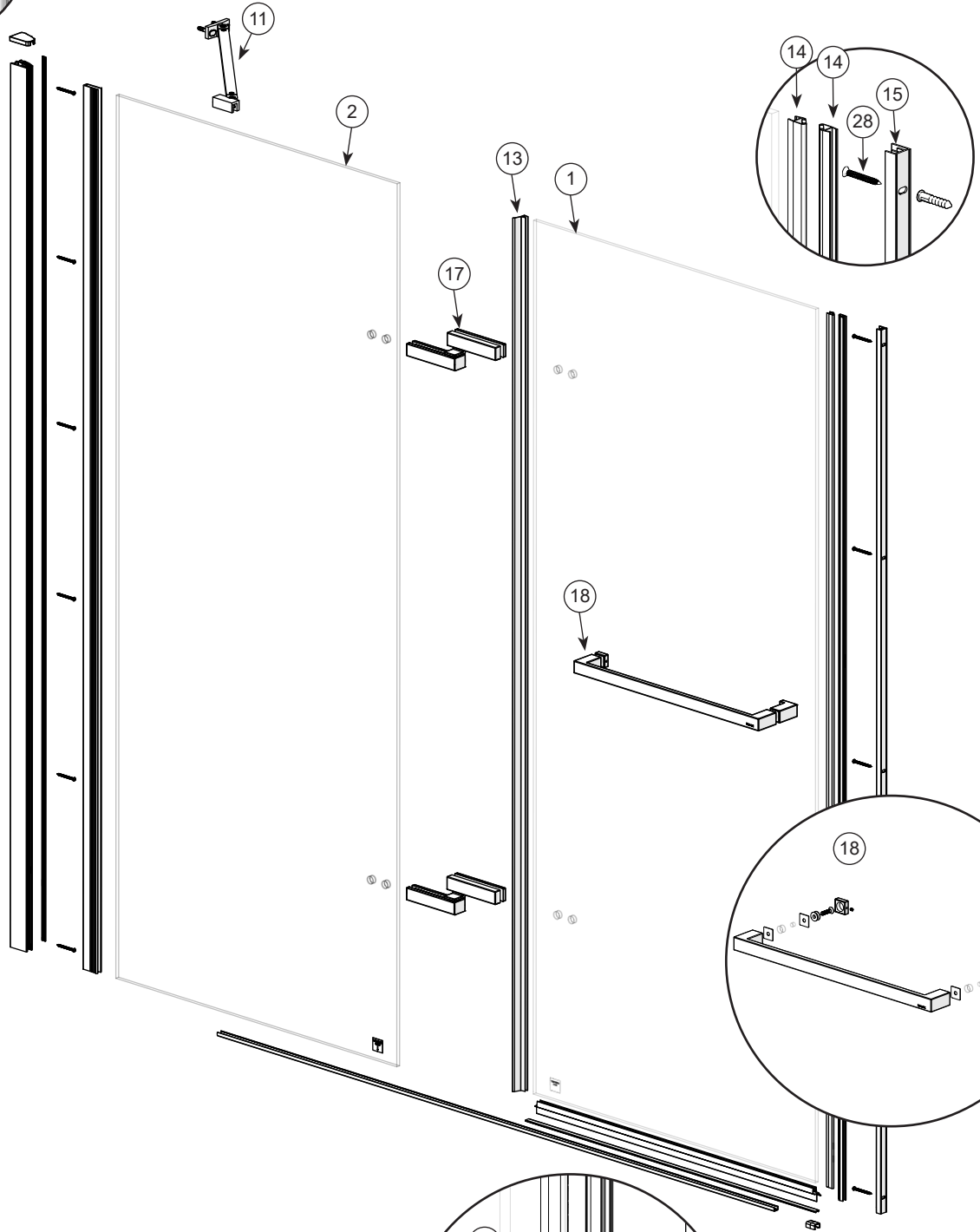
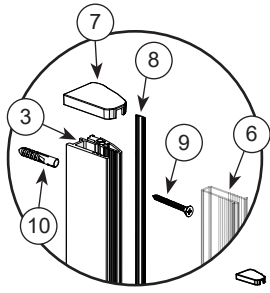

**PARTS** | **PIÈCES** | **PIEZAS**  
 AND COMPONENTS | ET COMPOSANTES | Y COMPONENTES

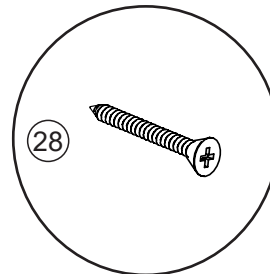
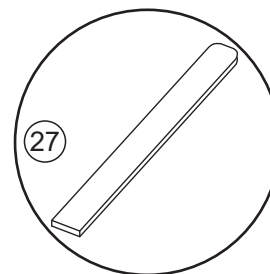
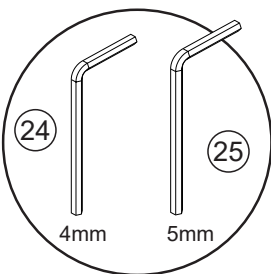
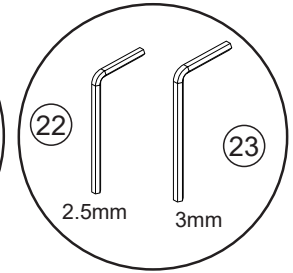
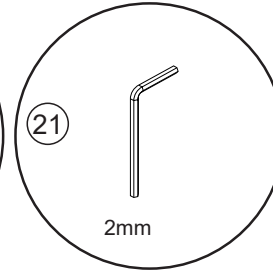
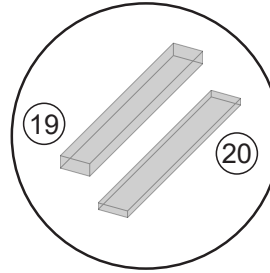
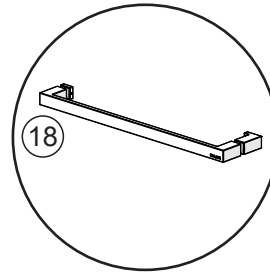
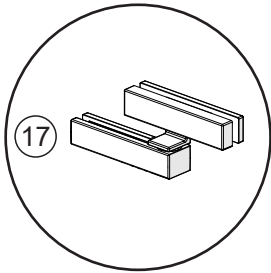
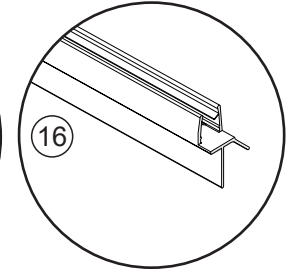
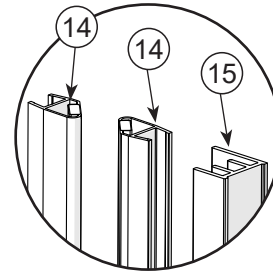
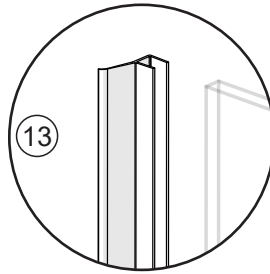
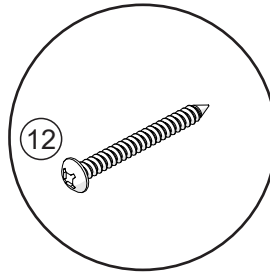
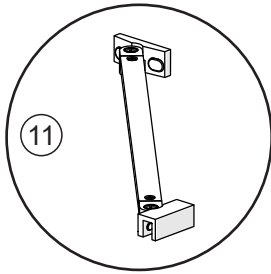
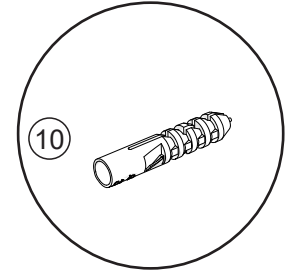
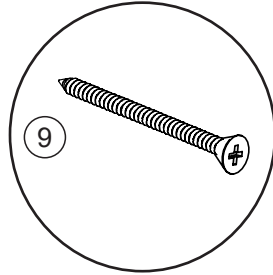
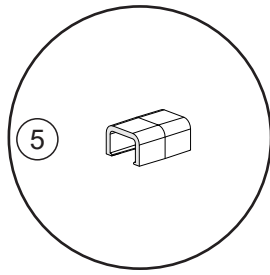
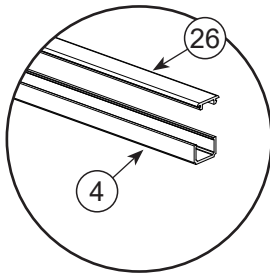
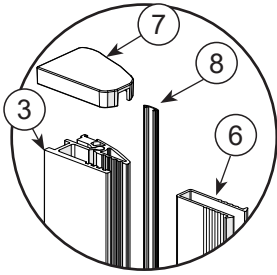

**PARTS** | **PIÈCES** | **PIEZAS**  
**AND COMPONENTS** | **ET COMPOSANTES** | **Y COMPONENTES**

**DOOR | PORTE | PUERTA**

#	Part	Nom de la pièce	Pieza	Qt Cant.
1	Door glass panel	Panneau de porte en verre	Panel de puerta en vidrio	1
2	Fixed glass panel	Panneau de verre fixe	Panel fijo	1
3	Wall jamb	Montant mural	Montante mural	1
4	Threshold bar	Barre du seuil	Barra del umbral	1
5	Threshold cap	Capuchon de la barre du seuil	Tapa de la barra del umbral	1
6	Wall jamb gasket	Joint de montant mural	Junta de montante mural	1
7	Wall jamb cover cap	Couvercle de montant mural	Tapa de la jamba mural	1
8	Screw cover	Cache-vis	Cubre tornillo	1
9	Wall jamb flat head screw 2 1/2"	Vis à tête plate pour montant mural 2 1/2po	Tornillo cabeza plana para montante mural 2 1/2"	7
10	Dry wall anchor	Ancrage à mur creux	Anclaje mural	12
	Dry wall anchor for arm	Ancrage à mur creux pour bras	Anclaje mural para brazo	2
11	Support arm	Bras de support	Brazo de soporte	1
12	Arm screws	Vis pour bras	Tornillos para brazo	2
13	Door gasket	Joint d'étanchéité de porte	Junta de estanqueidad de puerta	1
14	Magnetic gasket kit	Ensemble de joint d'étanchéité magnétique	Conjunto de junta de estanqueidad magnética	1
15	Magnetic wall jamb	Montant mural magnétique	Montante mural magnético	1
16	Drip shield	Défecteur	Deflector	1
17	Hinge	Charnière	Bisagra	1
18	Handle	Poignée	Manija	1
19	Shims 1/8"	Calles 1/8 po	Cuñas 1/8"	2
20	Shims .040	Calles .040	Cuñas .040	4
21	Allen key 2mm	Clé Allen 2mm	Llave Allen 2mm	1
22	Allen key 2.5mm	Clé Allen 2.5mm	Llave Allen 2.5mm	1
23	Allen key 3mm	Clé Allen 3mm	Llave Allen 3mm	1
24	Allen key 4mm	Clé Allen 4mm	Llave Allen 4mm	1
25	Allen key 5mm	Clé Allen 5mm	Llave Allen 5mm	1
26	Threshold cover	Couvercle de seuil	Tapa del nicho	1
27	Insert tool	Outil d'insertion	Herramienta de inserción	1
28	Magnetic wall jamb flat head screw 1 1/2"	Vis à tête plate pour montant mural magnétique 1 1/2po	Tornillo cabeza plana para montante mural magnético 1 1/2"	5

**TOOLS | OUTILS | HERRAMIENTAS**  
**REQUIRED | REQUIS | NECESARIAS**

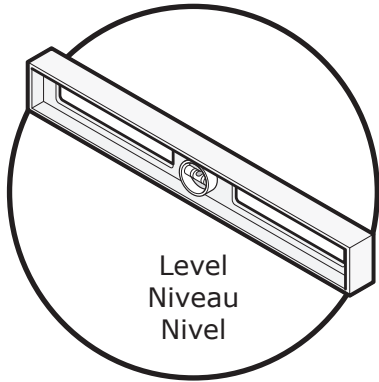

Level  
Niveau  
Nivel

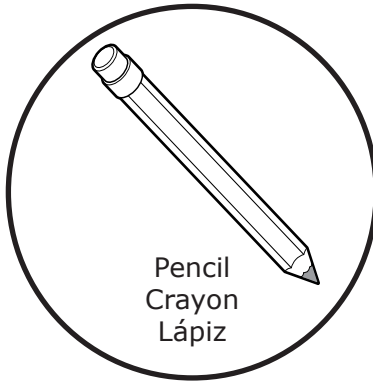

Pencil  
Crayon  
Lápiz

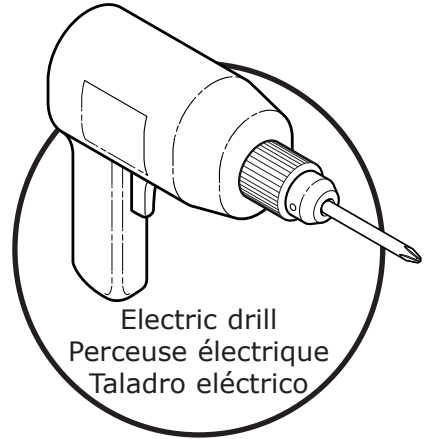

Electric drill  
Perceuse électrique  
Taladro eléctrico

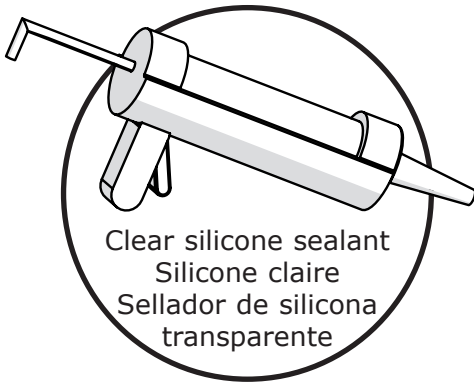

Clear silicone sealant  
Silicone claire  
Sellador de silicona  
transparente

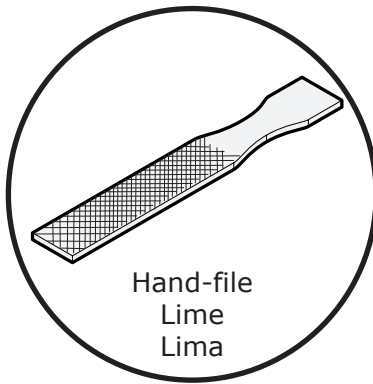

Hand-file  
Lime  
Lima



1/4" ceramic drill bit  
Mèche à céramique  
de 1/4 po.  
Broca para  
ceramica

15/64" drill bit  
Mèche de 15/64po  
Broca de 15/64"

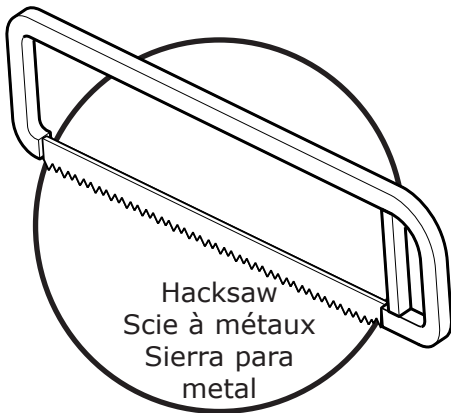

Hacksaw  
Scie à métaux  
Sierra para  
metal



Cutting pliers  
Pince coupante  
Alicata de  
corte

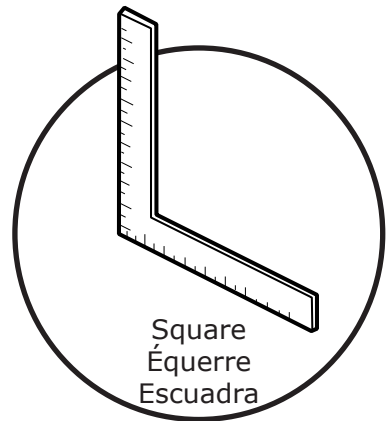

Square  
Équerre  
Escuadra

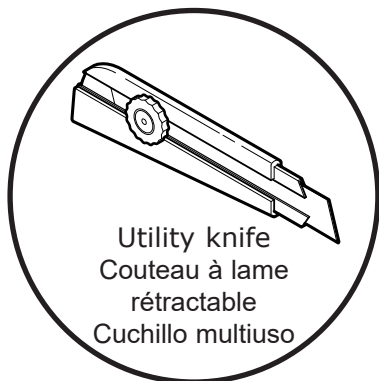

Utility knife  
Couteau à lame  
rétractable  
Cuchillo multiuso



Security equipment  
Équipement de sécurité  
Equipamiento  
de seguridad

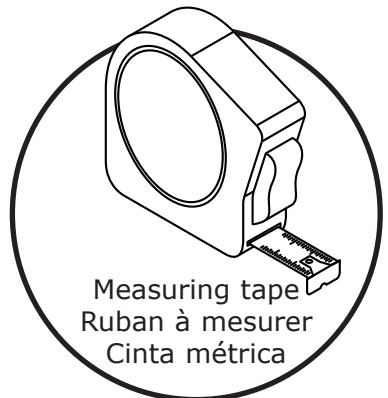

Measuring tape  
Ruban à mesurer  
Cinta métrica



# BEFORE | AVANT | ANTES

YOU BEGIN | DE COMMENCER | DE COMENZAR



Make sure that the door and panel fit within the shower enclosure. To do so, measure the height, width and depth of the shower threshold, and compare these measures to those of the door and panel.

**S'assurer que la porte et le panneau s'ajustent bien par rapport à l'ouverture prévue pour la douche. Pour ce faire, il faut mesurer la hauteur, la largeur et la profondeur du seuil et comparer les mesures prises à celles dans l'encadré ci-dessous.**

**Asegúrese de que la puerta y el panel se ajusten a la cabina de ducha. Mida la altura, el ancho y la profundidad del umbral de ducha y compare esas medidas con las de la puerta y el panel.**

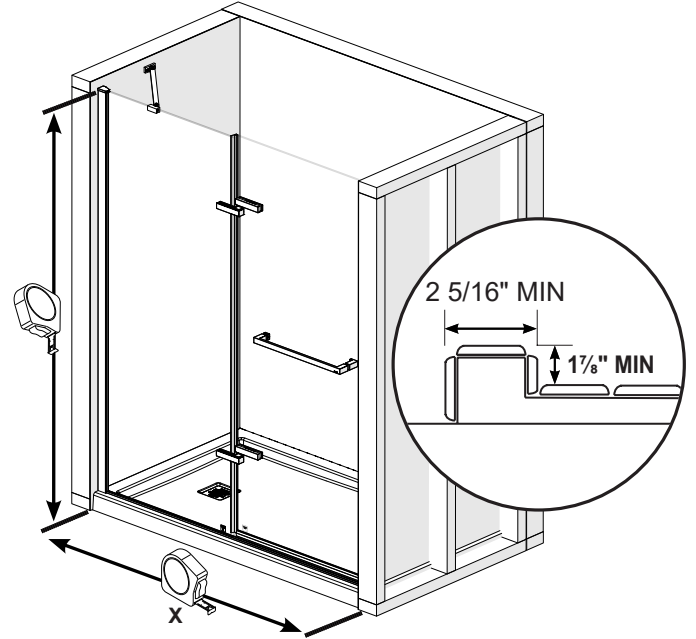
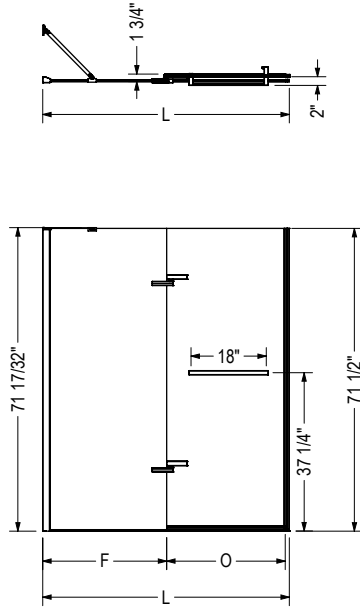

Code	Description	L	F	O
139575	Reveal Sleek 71 1/2" x 32 1/2" - 35 1/2"	32 1/2" - 35 1/2"	5 3/8"	23 3/4" - 26 3/4"
139576	Reveal Sleek 71 1/2" x 38" - 41"	38" - 41"	10 7/8"	23 3/4" - 26 3/4"
139577	Reveal Sleek 71 1/2" x 41 1/2" - 44 1/2"	41 1/2" - 44 1/2"	14 3/8"	23 3/4" - 26 3/4"
139578	Reveal Sleek 71 1/2" x 44" - 47"	44" - 47"	16 7/8"	23 3/4" - 26 3/4"
139579	Reveal Sleek 71 1/2" x 51 1/2" - 54 1/2"	51 1/2" - 54 1/2"	24 3/8"	23 3/4" - 26 3/4"
139580	Reveal Sleek 71 1/2" x 56" - 59"	56" - 59"	28 7/8"	23 3/4" - 26 3/4"

- Wall adjustment = 3/4"



Compare the X measurement to the chart below. **If X is MORE than the maximal measurement below you won't be able to install this door in your shower alcove.**

**Comparer la mesure X prise précédemment avec les valeurs du tableau ci-dessous. Si X est PLUS élevée que la mesure maximale ci-dessous, vous ne pourrez pas installer cette porte dans votre cabine de douche.**

**Comparar la medida X con las de la tabla abajo. Si X es MÁS que la medida máxima mostrada abajo, no podrá instalar esta puerta en su cabina de ducha.**

Alcove/Nicho	Min.	Max.
36"	32 1/2" (826mm)	35 1/2" (902mm)
42"	38" (965mm)	41" (1041mm)
45"	41 1/2" (1054mm)	44 1/2" (1130mm)

Alcove/Nicho	Min.	Max.
48"	44" (1118mm)	47" (1194mm)
55"	51 1/2" (1308mm)	54 1/2" (1384mm)
60"	56" (1422mm)	59" (1499mm)



Horizontal and vertical studs are needed in order to install the water fixtures. See appropriate installation guides.

**Des 2' x 4' horizontaux et verticaux doivent être installés pour l'installation des composants de robinetterie. Voir les guides d'installation correspondants.**

**Se necesitan montantes horizontales y verticales para poder instalar los accesorios de plomería. Ver las guías de instalación apropiadas.**



A two person installation is recommended.

**Une installation par deux personnes est recommandée.**

**Se recomienda realizar la instalación entre dos personas.**





# BEFORE | AVANT | ANTES

YOU BEGIN | DE COMMENCER | DE COMENZAR



**E**

Double the studs (2x4) where the wall jambs will be installed.  
**Doubler les montants de bois (2x4) là où les montants muraux seront installés.**  
*Duplique los montantes (2x4) en los lugares en los que se instalarán las jambas murales.*

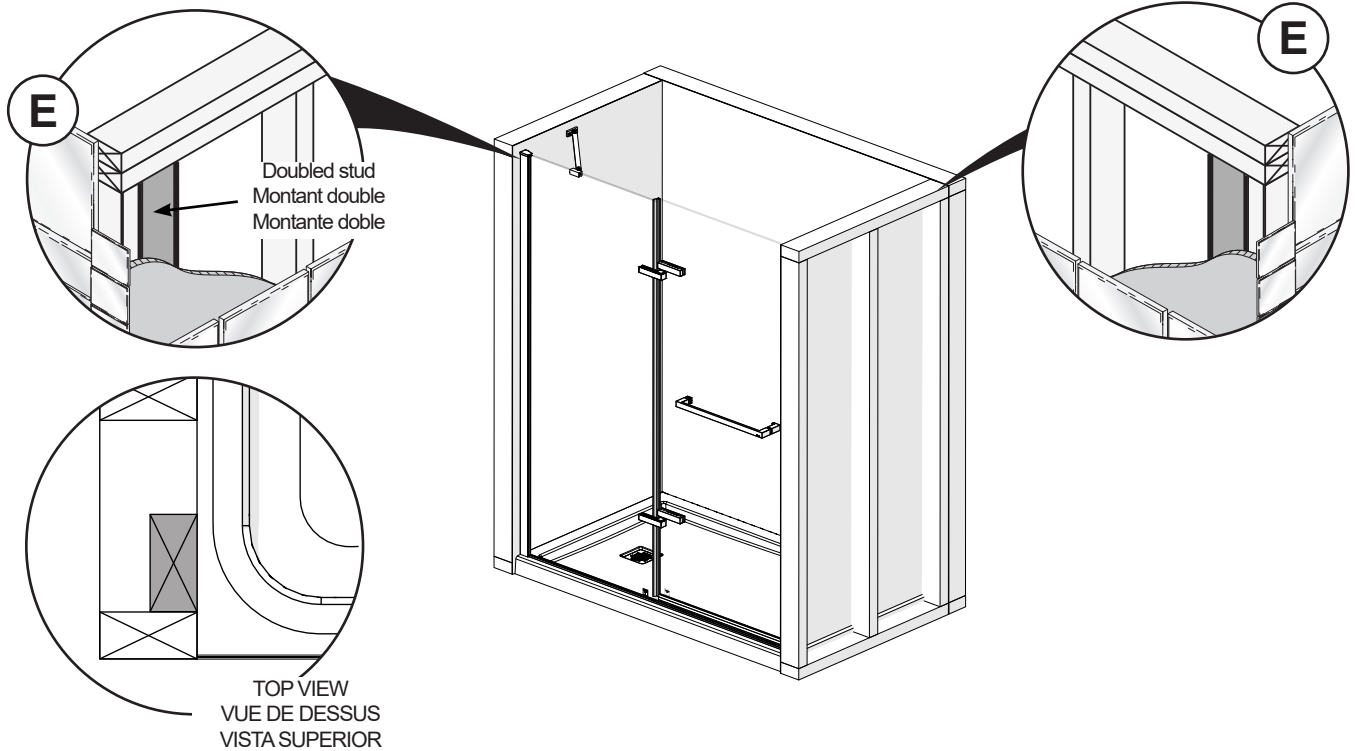

**F**

Verify that the shower base is perfectly leveled.  
**Vérifier que la base est parfaitement de niveau.**  
*Verificar que la base de ducha esta completamente nivelada.*

**F**

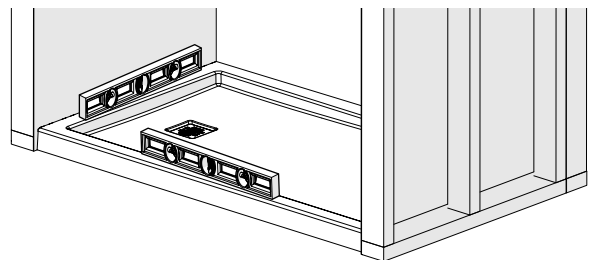

**G**

Place cardboard at the bottom of base to protect finish.  
**Placer le carton à l'intérieur de la base pour protéger la finition.**  
*Coloque el cartón en la parte inferior de la base para proteger el acabado.*

**G**

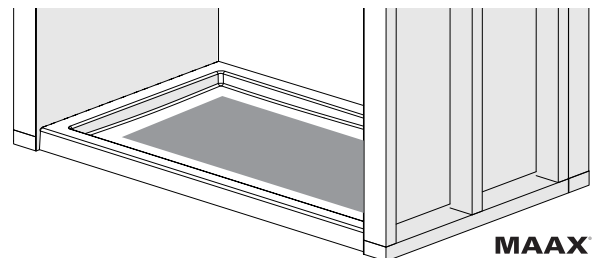

**1**

Parts required:  
Pièces requis:  
Partes requeridas:

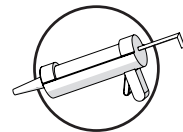
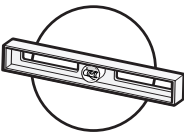
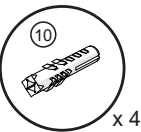
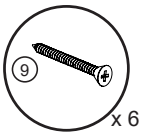
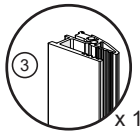

## WALL JAMB INSTALLATION INSTALLATION DU MONTANT MURAL INSTALACIÓN DEL MONTANTE MURAL

**A.** Place the wall jamb on the threshold and against the shower wall. Align it with the end of the base radius. Verify that it is leveled. Mark the position of the wall jamb fastening holes on the shower wall. Remove the wall jamb.

**A.** Mettre le montant mural sur seuil et contre le mur de douche. L'aligner avec la fin du rayon de la base. Valider qu'il est de niveau. Marquer la position des trous de fixation du montant mural. Enlever le montant mural.

**A.** Colocar el montante mural sobre el umbral y contra la pared de la ducha. Alinearlo con el fin del radio de la base. verificar que esta a nivel. Marcar la posición de los orificios de fijación del montante mural. Retirar el montante.

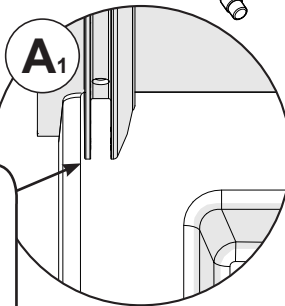
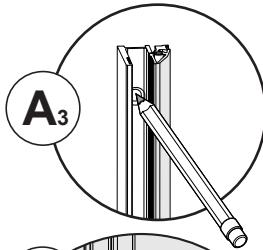

Align them with the end of the base radius.

Les aligner avec la fin du rayon de la base.

Alinearlos con el fin del radio de la base.

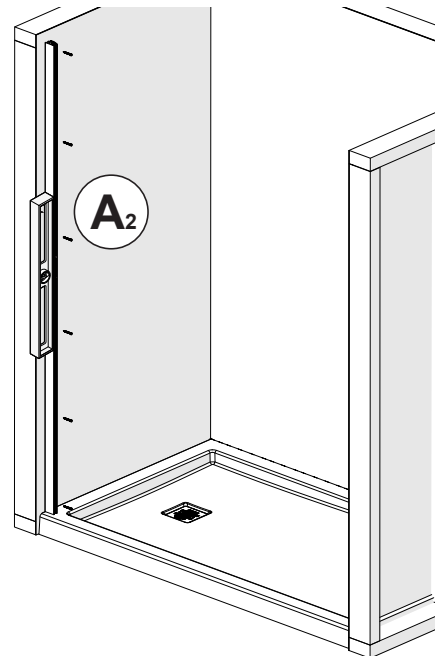

**B.** Drill the holes with the 15/64" drill bit. Apply silicone inside the holes. \*Insert the wall anchors if there is no stud behind the wall jamb.

**B.** Percer les trous avec le foret 15/64po. Appliquer du silicone dans les trous. \*Insérer des ancrages muraux s'il n'y a pas de montants en bois à l'arrière des montants muraux.

**B.** Taladrar los agujeros con la broca de 15/64". Aplique silicona dentro de los agujeros. \*Inserte los anclajes de pared, si no hay montantes detras de las jambas murales.

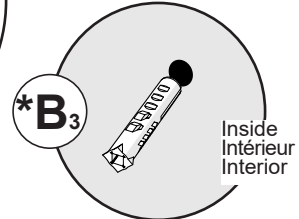
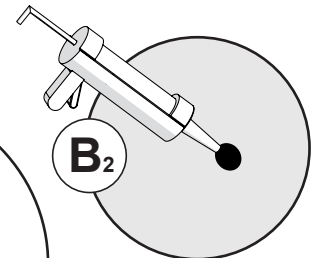
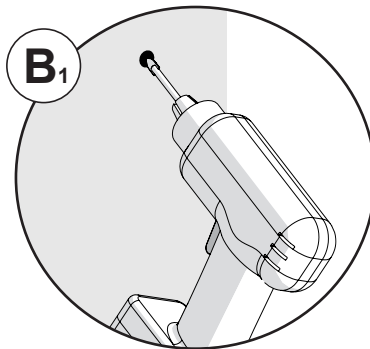

**C.** Apply a bead of silicone at the bottom where the wall jamb will sit. Place the wall jamb back against the wall and fasten with the provided screws.

**C.** Appliquer un cordon de silicone sur le seuil contre le mur où le montant mural sera installé. Placer le montant mural contre le mur et visser à l'aide des vis fournies.

**C.** Aplicar un cordón de silicona en la parte inferior del umbral contra el muro donde el montante mural sera instalado. Colocar el montante mural contra la pared y sujetar con los tornillos suministrados.

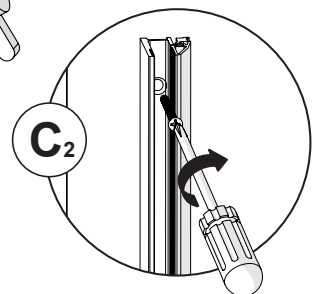
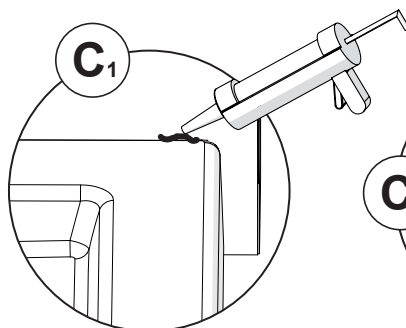



**2**

Parts required:  
 Pièces requis:  
 Partes requeridas:

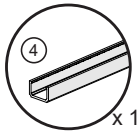

**THRESHOLD BAR INSTALLATION**  
**INSTALLATION DE LA BARRE DU SEUIL**  
**INSTALACIÓN DE LA BARRA DEL UMBRAL**

**A.** Measure the distance between the wall jamb and the shower wall and subtract 1/8" to that measurement.

**A. Mesurer la distance entre le montant mura et le mur de douche et soustraire 1/8 po à ce mesure.**

**A. Medir la distancia entre el montante mural y el muro de ducha y restar 1/8" de esa medida.**

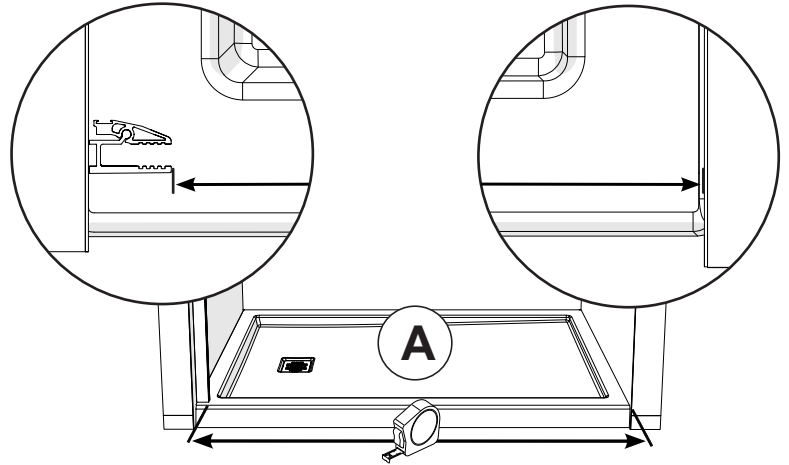

**B.** Cut the threshold bar to the recently taken measurement.

**B. Couper la barre du seuil selon la mesure calculée précédemment.**

**B. Cortar la barra del umbral según la medida tomada recientemente.**

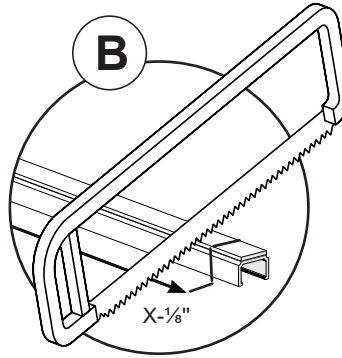

**C.** Dry fit the threshold bar. Mark the position. Remove it from the shower. Remove taper under threshold bar and place it on the threshold aligned with the mark and parallel to the outer edge of the base.

**C. Faire une installation à sec de la barre du seuil. Marquer la position de la pièce. Enlever la pièce. Retirer la pellicule sous la barre du seuil et la positionner sur le seuil aligné avec le repère et parallèlement au bord extérieur de la base.**

**C. Hacer una instalación en seco de la barra del umbral. Retirar laa pieza de la ducha. Retire el taper debajo de la barra del umbral y colocar en el umbral alineado con la marca y paralelo al borde exterior de la base.**

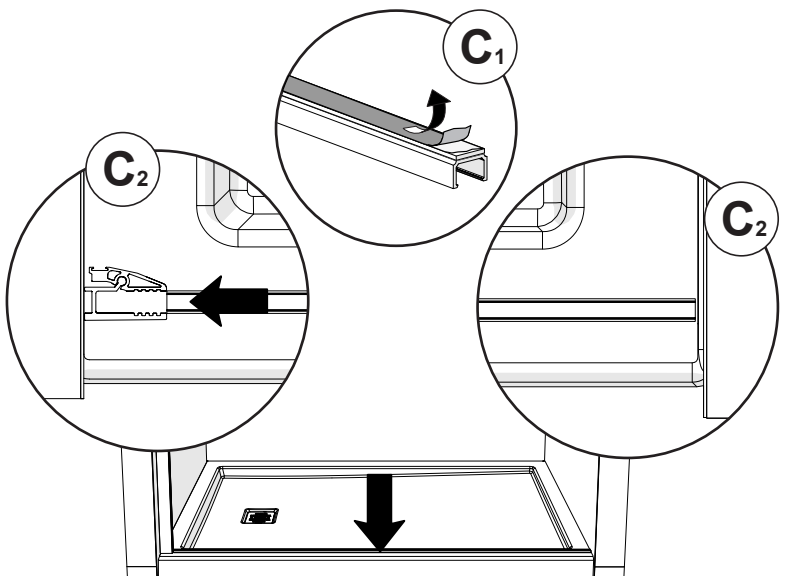



For model 139575 (32 1/2 - 35 1/2 x 71 1/2 in.) ONLY  
**Pour le modèle 139575 (32 1/2 - 35 1/2 x 71 1/2 po.) SEULEMENT**  
 Para el modelo 139575 (32 1/2 - 35 1/2 x 71 1/2".) ÚNICAMENTE

**3\***

Parts required:  
 Pièces requis:  
 Partes requeridas:

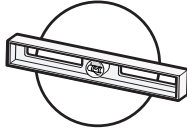
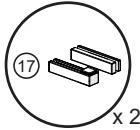

**HINGES INSTALLATION**  
**INSTALLATION DES CHARNIÈRES**  
**INSTALACIÓN DE LAS BISAGRAS**

**A.** Install the bottom parts of the hinges on the fixed panel BEFORE inserting the glass in the wall jamb. Square them.

**A. Fixer les parties inférieures des charnières sur le panneau fixe AVANT d'insérer le verre dans le montant mural. Les mettre à l'équerre.**

**A. Fijar las piezas inferiores de las bisagras al panel fijo ANTES de insertar el vidrio en el montante mural. Ponerlas a escuadra.**

**B.** Insert the caps on the hinges.

**B. Insérer les capuchons sur les charnières.**

**B. Insertar las tapas en las bisagras.**

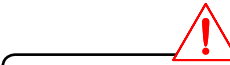

Make sure the hinges are well tightened and square on the fixed panel.

**S'assurer que les charnières sont bien serrées et à l'équerre sur le panneau fixe.**

*Asegurarse de que las bisagras estén bien ajustadas y a escuadra con el panel fijo.*

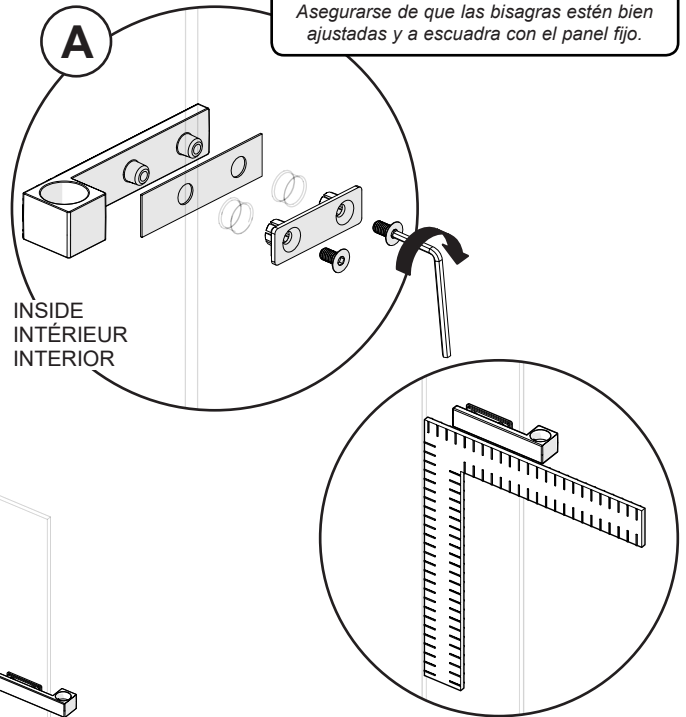

Caps won't fit if over tighten the screws.

**Les capuchons ne rentrent pas si les vis sont trop serrées.**

*Las tapas no encajarán si aprietan demasiado los tornillos.*

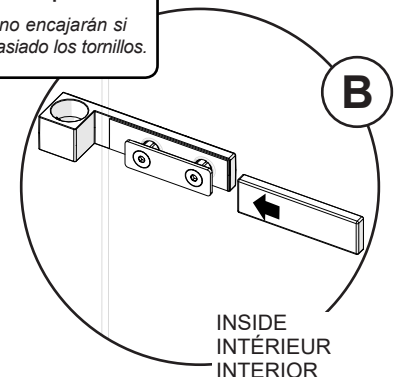

# 3

Parts required:  
Pièces requis:  
Partes requeridas:

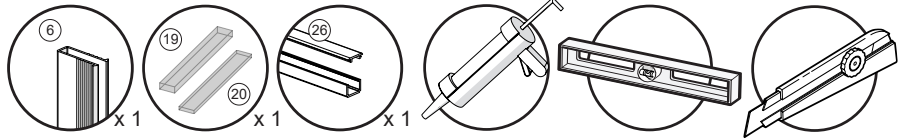

## FIXED PANEL INSTALLATION INSTALLATION DU PANNEAU FIXE INSTALACIÓN DEL PANEL FIJO

**A.** Apply silicone inside the U-channel. Insert the wall jamb gasket on the fixed panel. Insert glass inside wall jamb and U-channel. Insert shim inside the U-channel to level the panel if needed. Cut gasket excess if needed.

**A.** Appliquer du silicone à l'intérieur du rail en U. Insérer le joint d'étanchéité sur le panneau fixe. Insérer le verre à l'intérieur du montant mural et du rail en U. Insérer des cales à l'intérieur du rail en U pour mettre de niveau le panneau au besoin. Couper l'excédent de joint si nécessaire.

**A.** Aplicar silicona dentro del riel-U. Insertar la junta de estanqueidad en el panel fijo. Inserte el vidrio dentro del montante mural y el riel en U. Insertar cuñas dentro del riel en U para nivelar el panel en caso de ser necesario. Corte el exceso de la junta si es necesario.

**!**  
Insert the glass according to the alcove opening.  
Placer le verre selon l'ouverture de l'alcôve.  
Insertar el vidrio según la apertura del nicho.

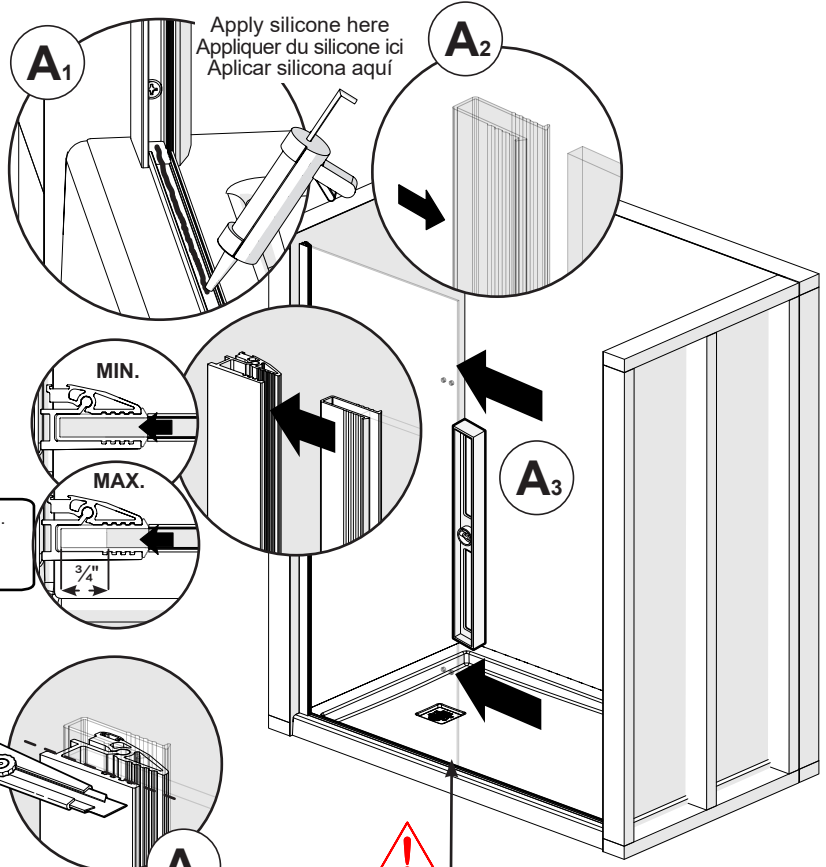

Apply silicone here  
Appliquer du silicone ici  
Aplicar silicona aquí

**A<sub>1</sub>**

**A<sub>2</sub>**

**A<sub>3</sub>**

**A<sub>4</sub>**

**!**  
Tempering logo at the bottom.  
Logo de trempo en bas.  
Logo templado en la parte inferior.

**B.** Measure the distance between the fixed panel edge and the end of the threshold bar. Cut threshold cover to that measure. Install threshold cover at a angle, then push until it clicks.

**B.** Mesurer la distance entre le panneau fixe et le bout de la barre du seuil. Couper la couvercle du rail selon la mesure calculée précédement. Installer la couvercle à angle et la pousser jusqu'au clic.

**B.** Medir la distancia entre el borde del panel fijo y el borde de la barra del umbral. Cortar la tapa del riel en U según la medida tomada recientemente. Instalar la cubierta del riel en angulo y empujar hasta que haga click.

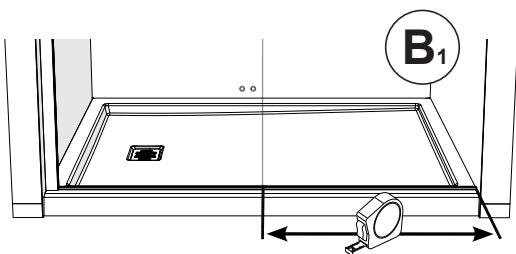

**B<sub>1</sub>**

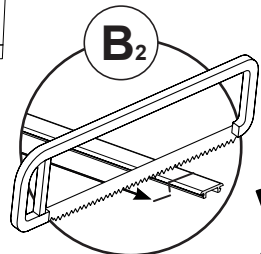

**B<sub>2</sub>**

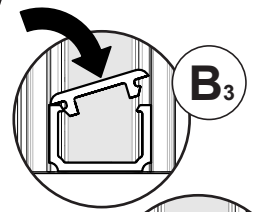

**B<sub>3</sub>**

CLICK!

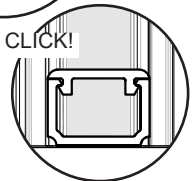

**4**

Parts required:  
Pièces requis:  
Partes requeridas:

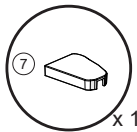
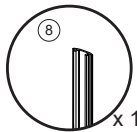
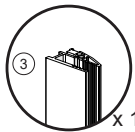

**FIXED PANEL INSTALLATION**  
**INSTALLATION DU PANNEAU FIXE**  
**INSTALACIÓN DEL PANEL FIJO**

- A. Fully tighten the set screws in the wall jamb.
- A. **Bien serrer les vis de pression du montant mural.**
- A. *Apretar completamente los tornillos de fijación de la jamba mural.*

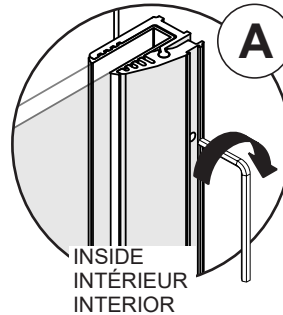

- B. Insert the screw cover in the wall jamb. Cut if needed.
- B. **Insérer le cache-vis dans le montant mural. Couper au besoin.**
- B. *Insertar el cobretornillo en la jamba mural. Cortar en caso de necesidad.*

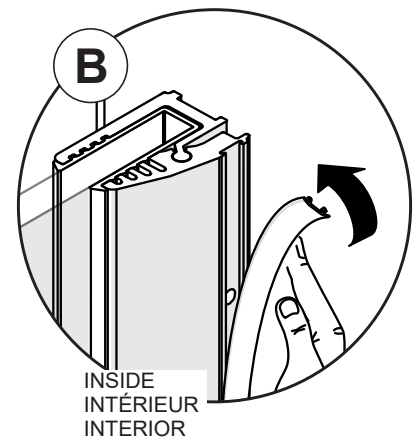

- C. Install the wall jamb cover.
- C. **Installer le couvercle du montant mural.**
- C. *Instalar la tapa de la jamba mural.*

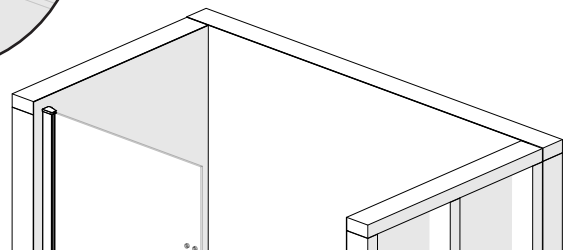
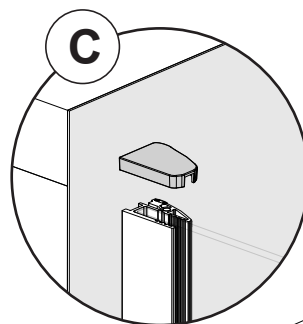

**5**

Parts required:  
Pièces requis:  
Partes requeridas:

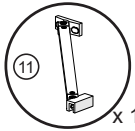

x 1

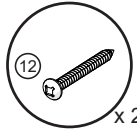

x 2

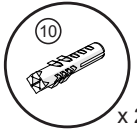

x 2

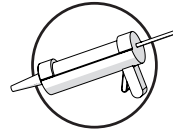

## SUPPORT ARM INSTALLATION INSTALLATION DU BRAS DE SOUTIEN INSTALACIÓN DEL BRAZO DE SOPORTE

**A.** Verify the panel is leveled. Preinstall the support arm on top of the panel. Verify that the arm is leveled and mark the position of the fastening holes. Remove the arm.  
**NOTE:** Not all models have a support arm.

**A.** Vérifier que le panneau est de niveau. Préinstaller le bras de support sur le dessus du panneau. Vérifier que le bras est de niveau et marquer la position des trous de fixation. Enlever le bras.

**REMARQUE:** tous les modèles n'ont pas de bras de support.

**A.** Verificar que el panel este nivelado. Preinstalar el brazo de soporte en la parte superior del panel. Verificar que el brazo este nivelado y marcar la posición de los agujeros de fijación. Quitar el brazo.

**NOTA:** No todos los modelos tienen un brazo de soporte.

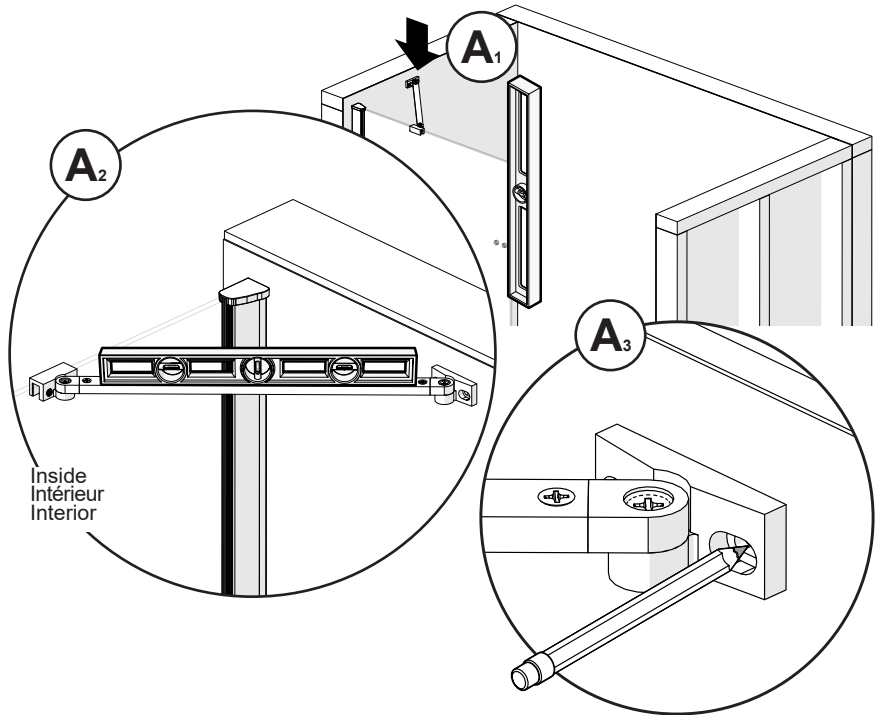

Inside  
Intérieur  
Interior

**B.** Drill the holes. Apply silicone inside the holes.  
\*Insert the wall anchors if there is no stud behind the wall jamb.

**B.** Percer les trous. Appliquer du silicone dans les trous.  
\*Insérer des ancrages muraux s'il n'y a pas de montants en bois à l'arrière des montants muraux.

**B.** Taladrar los agujeros. Aplique silicona dentro de los agujeros.  
\*Inserte los anclajes de pared, si no hay montantes detras de las jambas murales.

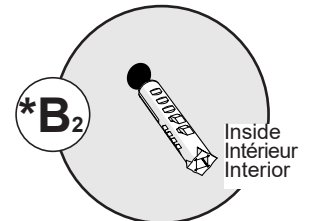
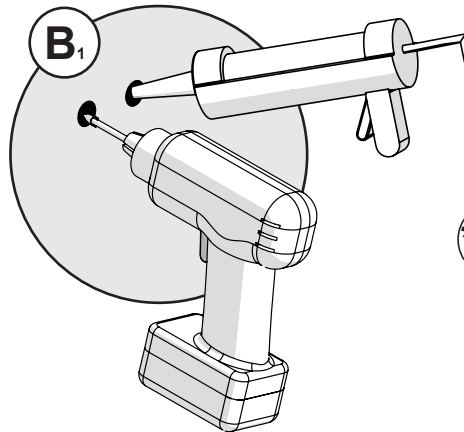

Inside  
Intérieur  
Interior

**C.** Install the support arm on top of the panel. Secure with the included screws. Install the screw covers.

**C.** Installer le bras de support sur le dessus du panneau. Fixer avec les vis fournies. Installer les cache-vis.

**C.** Instalar el brazo de soporte en la parte superior del panel. Asegurar con los tornillos incluidos. Instalar los cubretornillos.

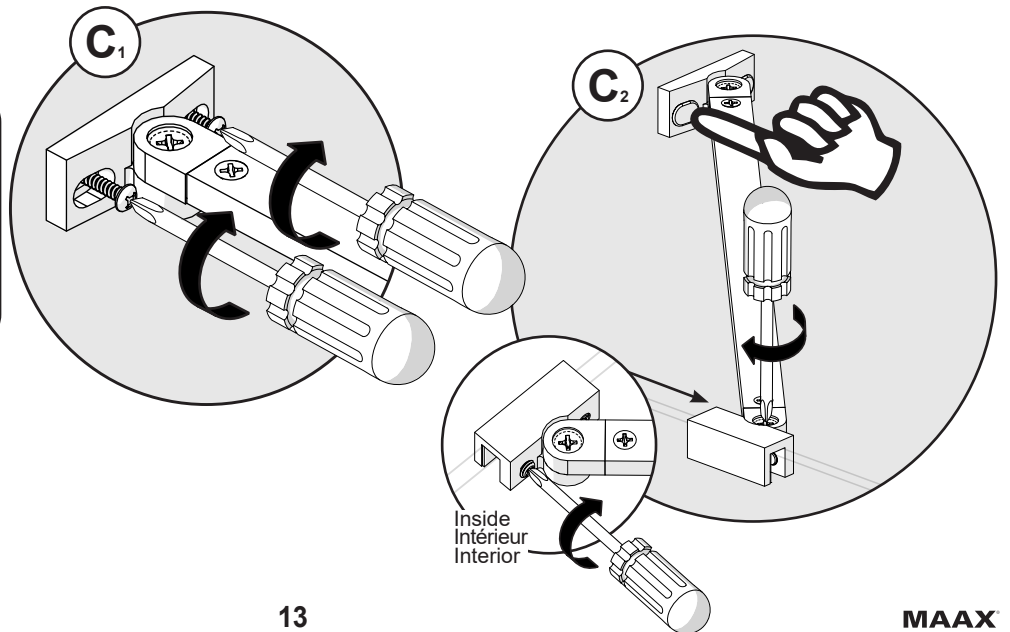

Inside  
Intérieur  
Interior



SKIP this step for model 139575 (32 1/2 - 35 1/2 x 71 1/2 in.) ONLY  
**SAUTER cette étape pour le modèle 139575 (32 1/2 - 35 1/2 x 71 1/2 po.) SEULEMENT**  
**SALTAR este paso para el modelo 139575 (32 1/2 - 35 1/2 x 71 1/2".) ÚNICAMENTE**

**6**

Parts required:  
 Pièces requis:  
 Partes requeridas:

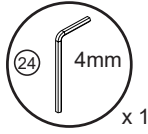
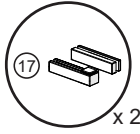

**HINGES INSTALLATION**  
**INSTALLATION DES CHARNIÈRES**  
**INSTALACIÓN DE LAS BISAGRAS**

**A.** Install the bottom parts of the hinges on the fixed panel. Square them.

**A. Fixer les parties inférieures des charnières sur le panneau fixe. Les mettre à l'équerre.**

**A. Fijar las piezas inferiores de las bisagras al panel fijo. Ponerlas a escuadra.**



Make sure the hinges are well tightened and square on the fixed panels.

**S'assurer que les charnières sont bien serrées et à l'équerre sur le panneau fixe.**

**Asegurarse de que las bisagras estén bien ajustadas y a escuadra con el panel fijo.**

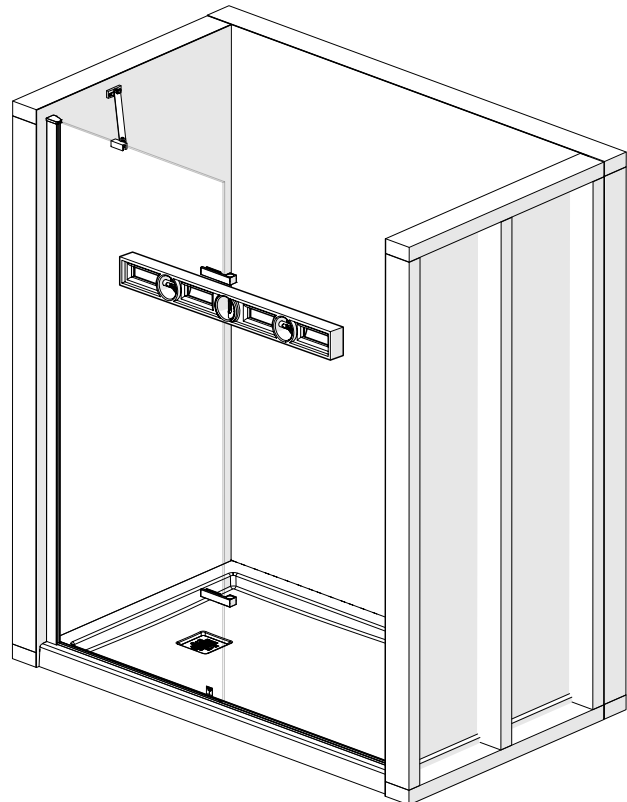
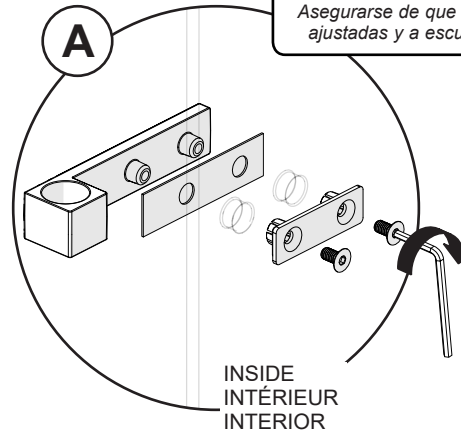

7

Parts required:  
Pièces requis:  
Partes requeridas:

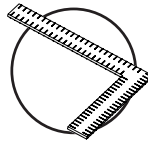
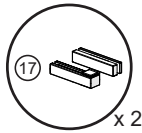



### HINGES INSTALLATION INSTALLATION DES CHARNIÈRES INSTALACIÓN DE LAS BISAGRAS

A. Place the door temporarily and safely on a wall over cardboard.

A. Appuyer la porte temporairement et sûrement contre un mur sur des cartons.

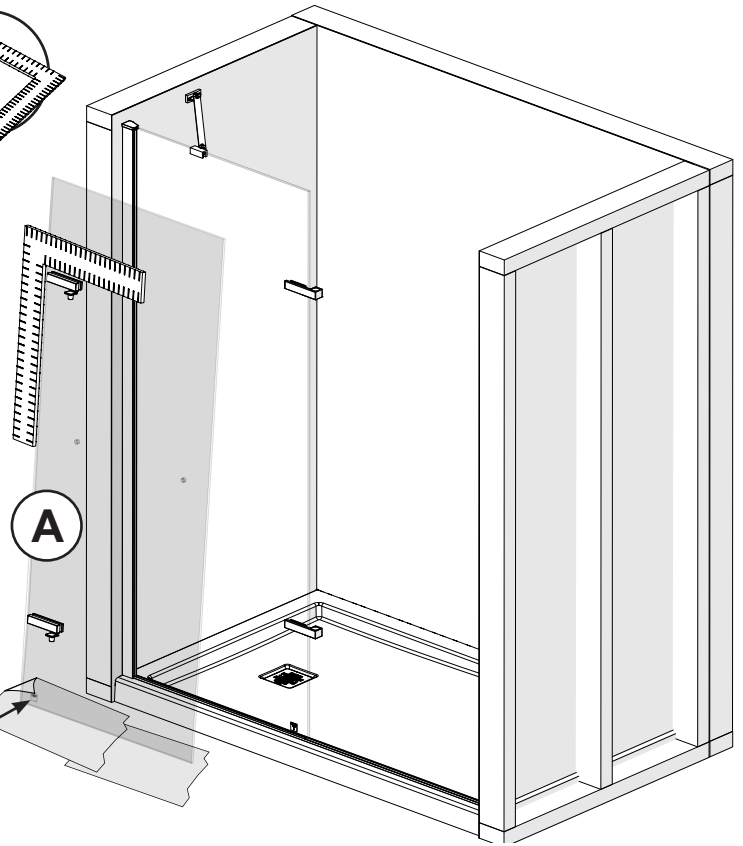
A. Apoyar la puerta provisoriamente y de manera segura sobre cartones.



  
Tempering logo at the bottom.  
Logo de trempé en bas.  
Logo templado en la parte inferior.

B. Make sure the door is installed side up based on given information. Validate the alignment of holes and the lower part of the glass.

B. S'assurer que la porte sera installé dans le bon sens à l'aide des indications. Valider l'alignement des trous et du dessus de verre.

B. Asegúrese de que la puerta se instalará en la dirección correcta según estas indicaciones. Validar el alineamiento de huecos y de la parte inferior del vidrio.

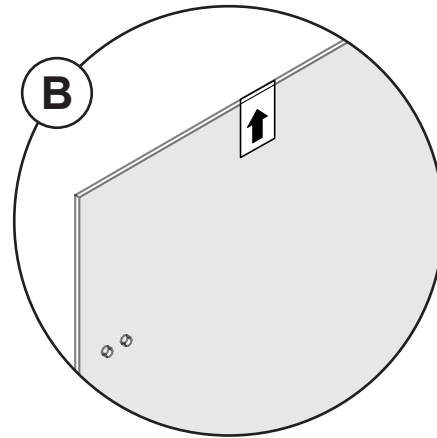

C. Install the top parts of the hinges on the door and square them.

C. Fixer les parties supérieures des charnières sur la porte et les mettre à l'équerre.

C. Fijar las piezas superiores de las bisagras a la puerta y ponerlas a escuadra.

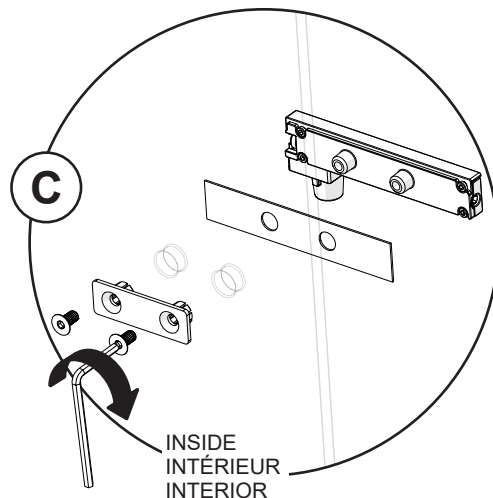

  
Make sure the hinges are well tightened and square on the fixed panels.

S'assurer que les charnières sont bien serrées et à l'équerre sur le panneau fixe.

Asegurarse de que las bisagras estén bien ajustadas y a escuadra con el panel fijo.

  
Do not overly tighten the screws.

Ne pas trop serrer les vis.

No apretar los tornillos demasiado.

8

Parts required:  
Pièces requis:  
Partes requeridas:

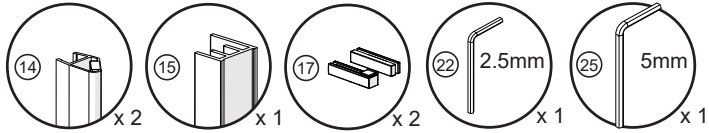

**DOOR INSTALLATION**  
**INSTALLATION DE LA PORTE**  
**INSTALACIÓN DE LA PUERTA**

**A.** Refer to the hinges blisterpack to select the appropriate guide. Insert it on the bottom hinges. Join the door to the fixed panel by inserting the top hinge in the bottom.

**A.** Se référer à l'emballage de quincaillerie pour sélectionner le bon guide. Insérer le guide dans la partie inférieure des charnières. Assembler la porte au panneau fixe en insérant la partie supérieure de la charnière dans la partie inférieure.

**A.** Referirse al empaque de las bisagras para seleccionar la guía apropiada. Insertar la guía en la parte inferior de las bisagras. Unir la puerta al panel fijo insertando las piezas superiores en las inferiores de las bisagras.

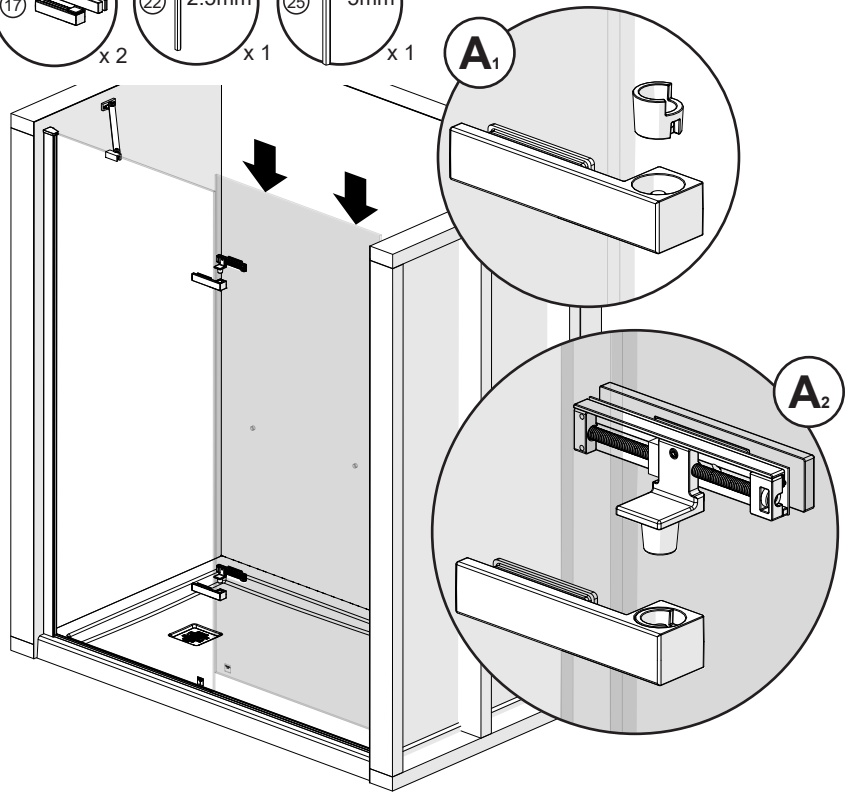

**B.** Insert the magnetic door gasket on the front edge of the door. Temporarily add the other magnetic jamb gasket and the magnetic jamb.

**B.** Insérer le joint d'étanchéité magnétique de porte sur le bord avant de la porte. Ajouter temporairement l'autre joint d'étanchéité magnétique et le montant mural magnétique.

**B.** Insertar la junta de estanqueidad magnética de puerta en el borde frontal de la puerta. Colocar temporalmente la otra junta de estanqueidad magnética y el montante mural magnético.

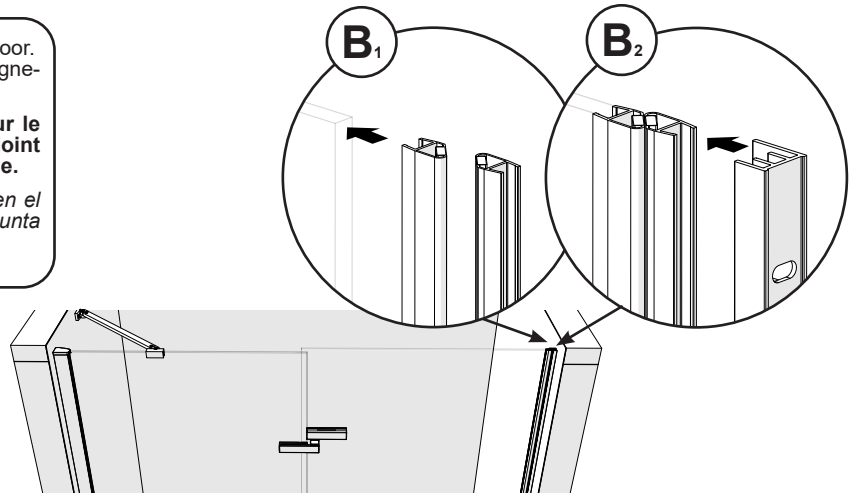

**C.** Loose the set screw. Adjust the hinges from left to right until the magnetic wall jamb is in contact with the shower wall. Mark the position of the wall jamb on the shower wall.

**C.** Desserrer la vis de réglage. Ajuster les charnières de gauche à droite jusqu'à ce que le montant mural magnétique soit en contact avec le mur de la douche. Marquer la position du montant mural sur le mur de la douche.

**C.** Aflojar el tornillo de fijación. Ajustar las bisagras de izquierda a derecha hasta que el montante mural magnético este en contacto con el muro de ducha. Marcar la posición del montante mural sobre el muro de ducha.

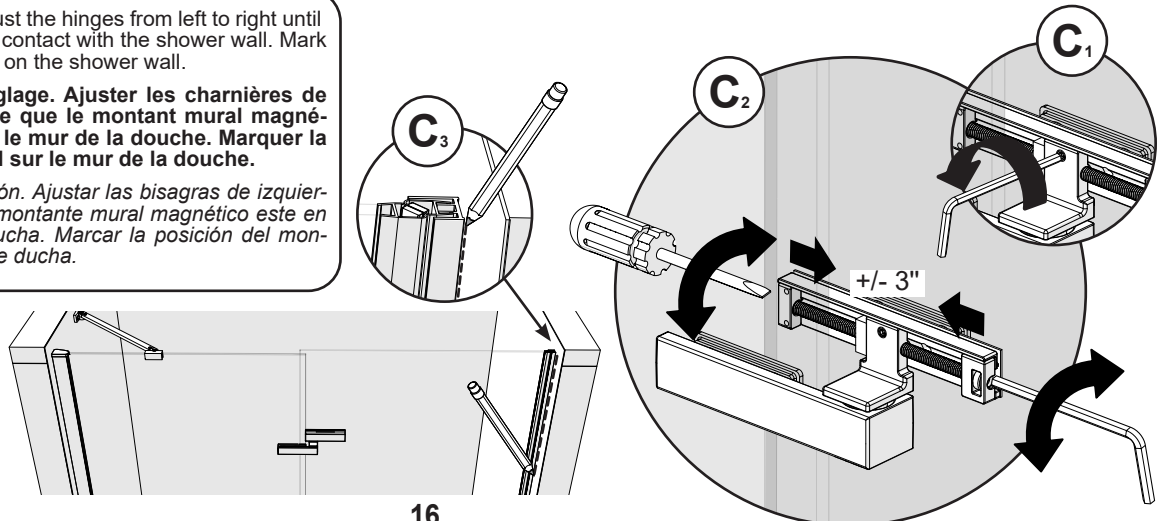



**9**

Parts required:  
Pièces requis:  
Partes requeridas:

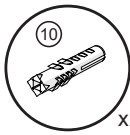

x 5

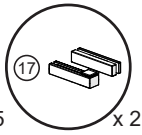

x 2

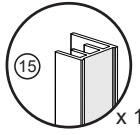

x 1

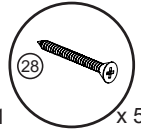

x 5

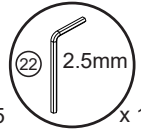

x 1

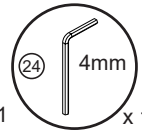

x 1

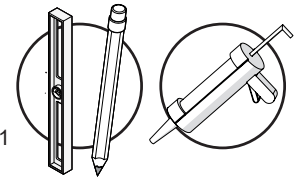

**DOOR INSTALLATION**  
**INSTALLATION DE LA PORTE**  
**INSTALACIÓN DE LA PUERTA**

**A.** Fasten the set screw. Secure the hinges with the provided screw.

**A. Serrer la vis de réglage. Sécuriser les charnières avec la vis fournie.**

**A. Apretar el tornillo de fijación. Asegurar las bisagras con el tornillo incluido.**

Do not overly tighten the set screws.

**Ne pas trop serrer les vis de réglage.**

**No apretar los tornillos de ajuste demasiado.**

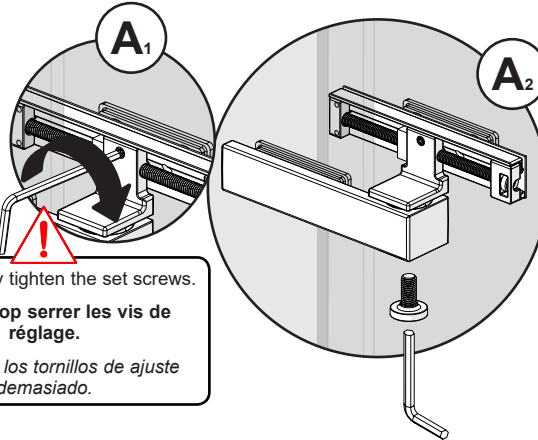

**B.** Place the magnetic wall jamb on top of the threshold, against the shower wall and aligned with the previously marked position. Verify that is leveled. Mark the position of the magnetic wall jamb fastening holes on the shower wall. Remove the wall jamb.

**B. Mettre le montant mural magnétique sur le seuil, contre le mur de douche et aligné avec la position précédemment marquée. Valider qu'il est de niveau. Marquer la position des trous de fixation du montant mural magnétique. Enlever le montant mural.**

**B. Colocar el montante mural sobre el umbral, contra la pared de la ducha y alineado con la posición marcada anteriormente. Verificar que esta a nivel. Marcar la posición de los orificios de fijación del montante mural magnético. Retirar el montante.**

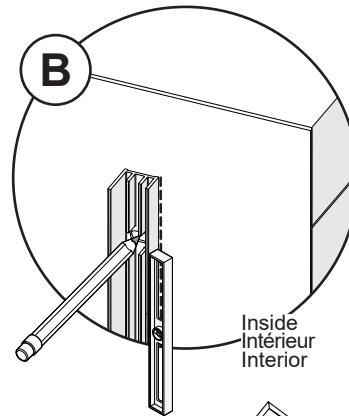

**C.** Drill the holes with the 15/64" drill bit. Apply silicone inside the holes. \*Insert the wall anchors if there is no stud behind the wall jamb.

**C. Percer les trous avec le foret 15/64po. Appliquer du silicone dans les trous.**

**\*Insérer des ancrages muraux s'il n'y a pas de montants en bois à l'arrière des montants muraux.**

**C. Taladrar los agujeros con la broca de 15/64". Aplique silicona dentro de los agujeros.**

**\*Inserte los anclajes de pared, si no hay montantes detras de las jambas murales.**

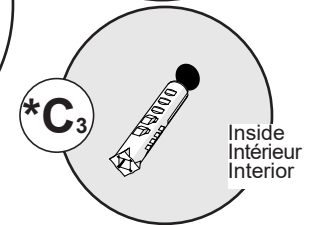
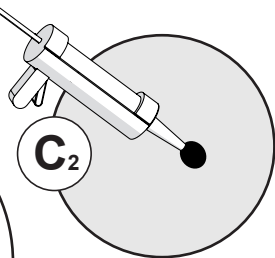
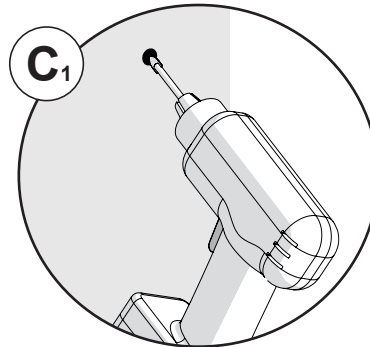

**D.** Apply a bead of silicone at the bottom where the wall jamb will sit. Place the wall jamb back against the wall and fasten with the provided screws.

**D. Appliquer un cordon de silicone sur le seuil contre le mur où le montant mural sera installé. Placer le montant mural contre le mur et visser à l'aide des vis fournies.**

**D. Aplicar un cordón de silicona en la parte inferior del umbral contra el muro donde el montante mural sera instalado. Colocar el montante mural contra la pared y sujetar con los tornillos suministrados.**

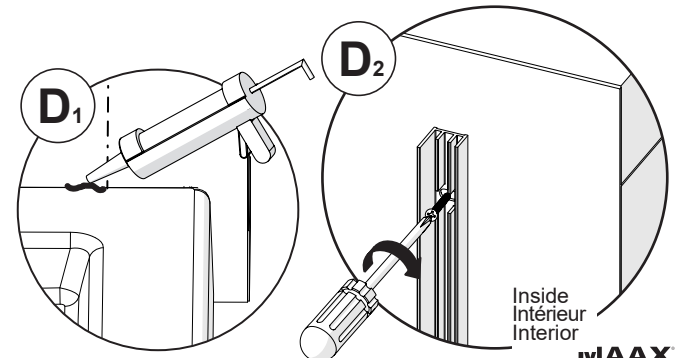

# 10

Parts required:  
Pièces requis:  
Partes requeridas:

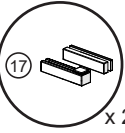
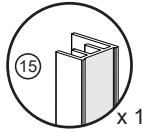
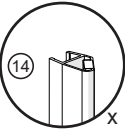
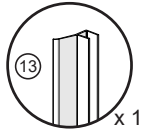

## DOOR INSTALLATION INSTALLATION DE LA PORTE INSTALACIÓN DE LA PUERTA

- A.** Insert the magnetic door gasket on the magnetic jamb.  
**A. Insérer le joint d'étanchéité magnétique de porte sur le montant mural magnétique.**  
**A.** Insertar la junta de estanqueidad magnética de puerta en el montante mural magnético.

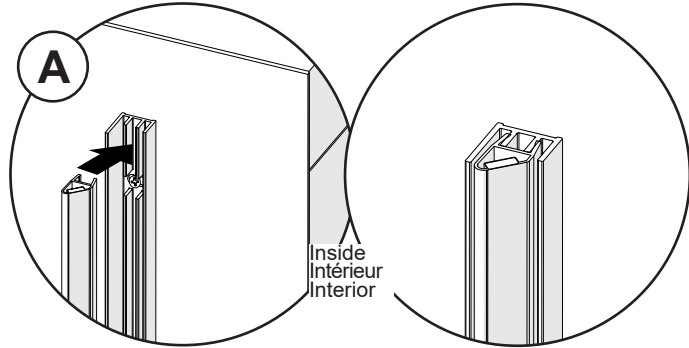

- B.** Insert the caps on the hinges.  
**B. Insérer les capuchons sur les charnières.**  
**B.** Insertar las tapas en las bisagras.

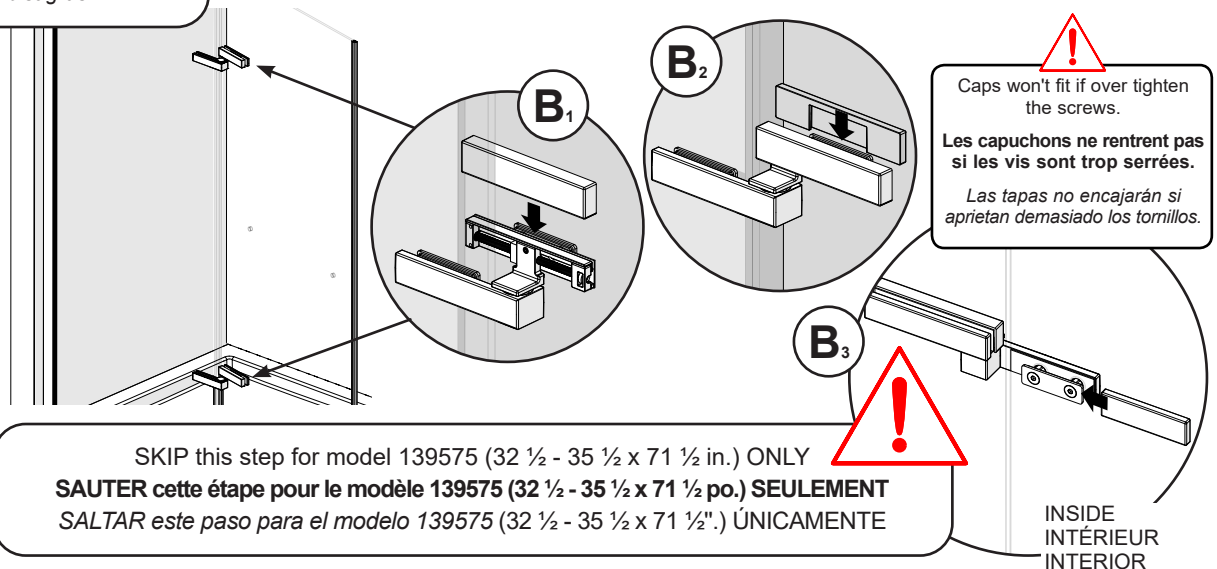

- C.** Insert the door gasket on the back edge of the door.  
**C. Insérer le joint d'étanchéité de porte sur le bord arrière de la porte.**  
**C.** Insertar la junta de estanqueidad de puerta en el borde posterior de la puerta.

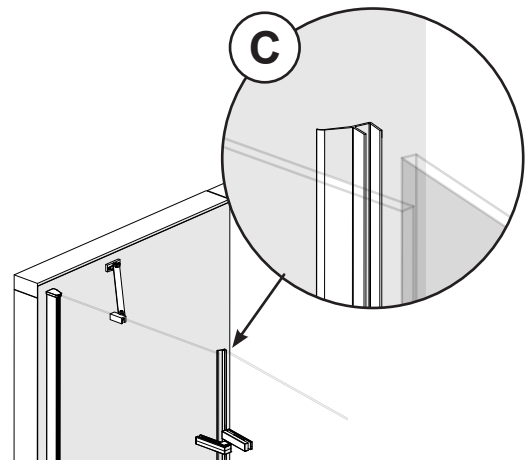

11

Parts required:  
Pièces requis:  
Partes requeridas:

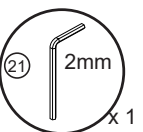
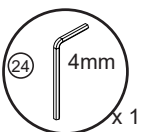
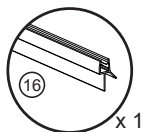
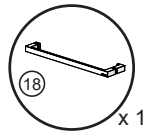

**FINISHING DETAILS**  
**DÉTAILS DE FINITION**  
**DETALLES DE ACABADO**

A. Install the handle on the door as shown.

A. Installer la poignée sur la porte tel que démontré.

A. Instalar la manija en la puerta como se muestra en la ilustración.

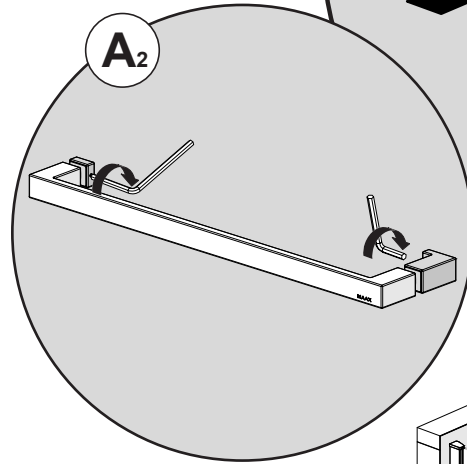
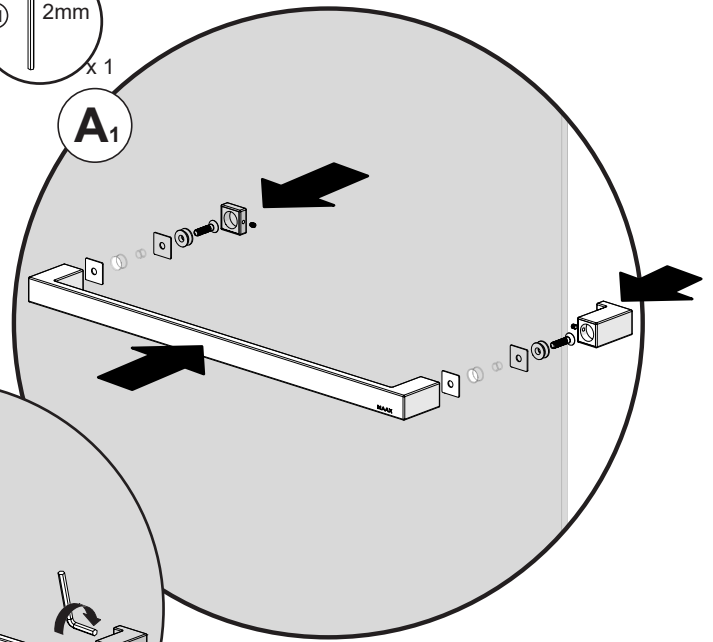

B. Install the drip shield on the bottom edge of the door.

B. Installer le déflecteur sur le rebord inférieur de la porte.

B. Instalar el deflector en el borde inferior de la puerta.

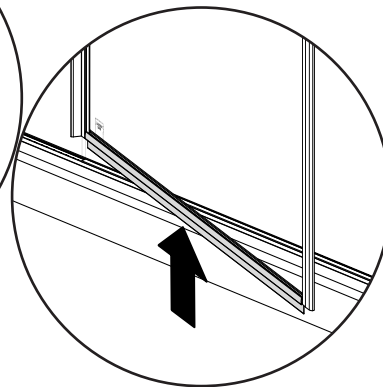
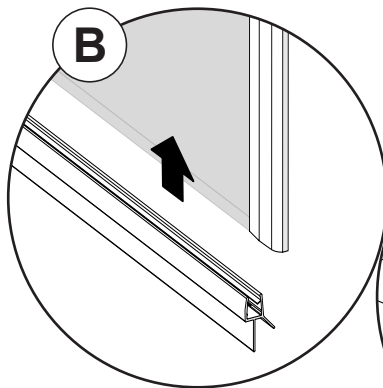
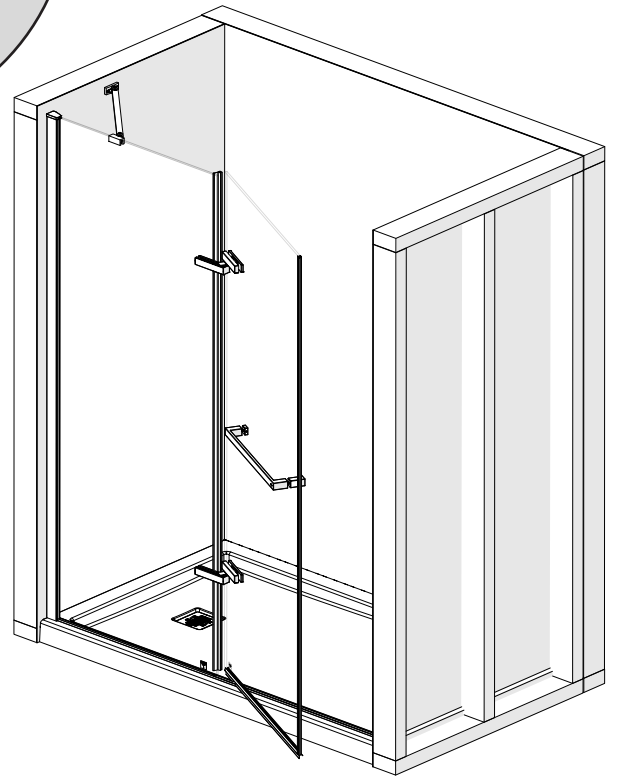

# 12

Parts required:  
Pièces requis:  
Partes requeridas:

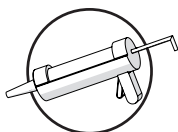
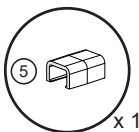

## APPLICATION OF THE SILICONE APPLICATION DU SILICONE APLICACIÓN DE LA SILICONA

**A.** Apply a bead of silicone under the threshold bar cap and place it at the edge of the threshold and against the shower wall.

**A.** Appliquer un joint de silicone sous le capuchon de la barre de seuil et le placer au bord de la barre du seuil et contre le mur de la douche.

**A.** Aplicar silicona debajo de la tapa de la barra del umbral y colóquela en el borde de la barra del umbral y contra la pared de la ducha.

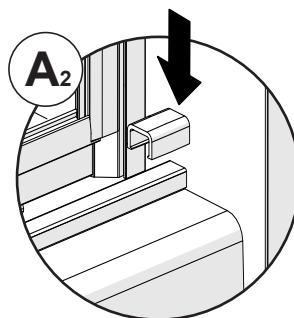
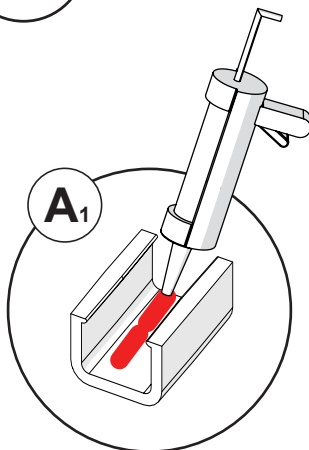

**B.** From outside the shower apply a bead of silicone along the wall jambs, the threshold on the base and around the threshold bar cap.

**B.** De l'extérieur de la douche, appliquer un joint de silicone le long des montants muraux, le seuil à la base et autour du capuchon de la barre du seuil.

**B.** Desde el exterior de la ducha, aplicar sellador de silicona a lo largo de los jambas murales, el umbral sobre la base y alrededor de la tapa de la barra del umbral.

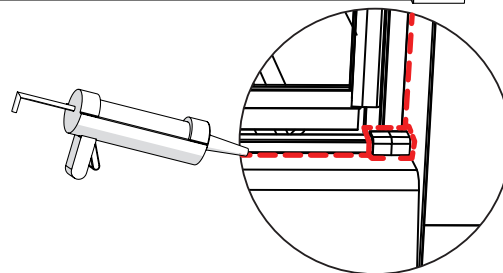
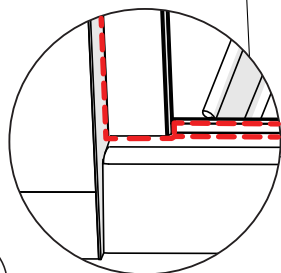
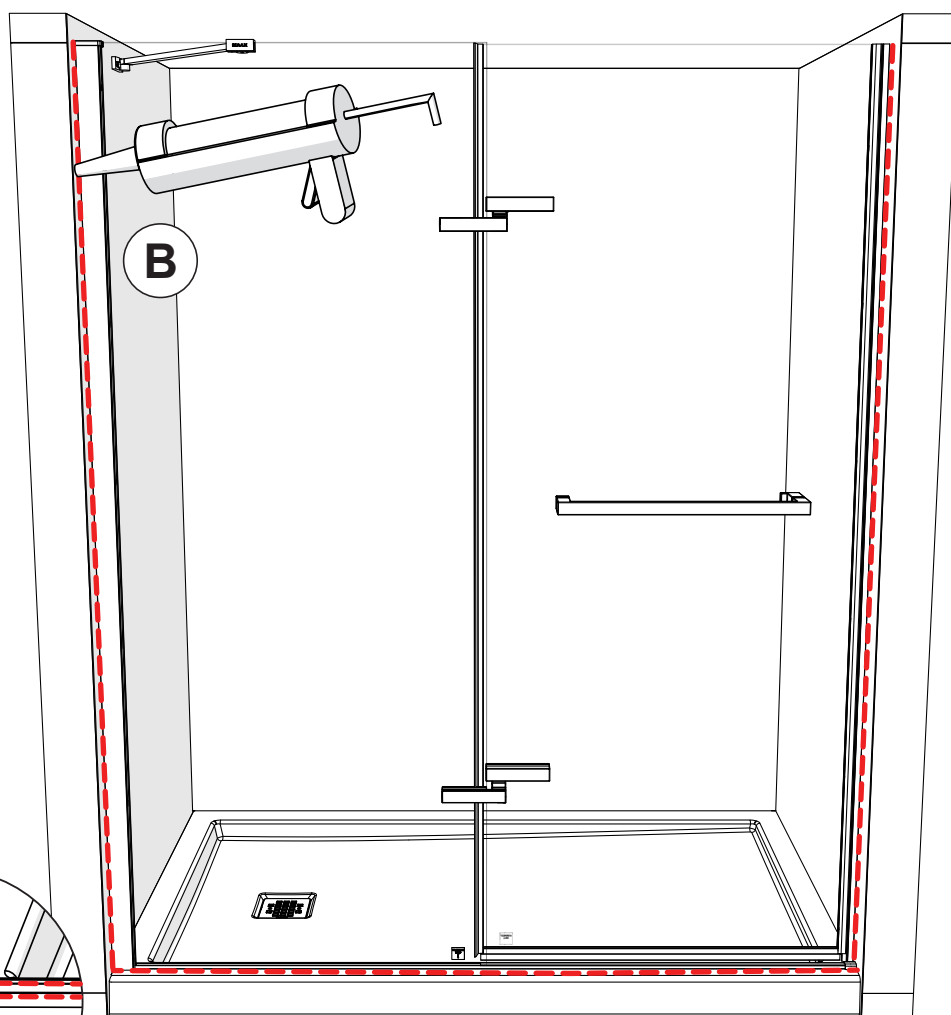

**24H**

Wait 24 hours before using the shower.

Attendez 24 heures avant d'utiliser la douche.

Espere 24 horas antes de utilizar la ducha.



# MAINTENANCE | ENTRETIEN | MANTENIMIENTO

Check me!  
Cochez-moi!  
Márcame!



Right after installation  
**Juste après l'installation**  
**Justo después de la instalación**

1. Open the door and verify it closes seamlessly. Also verify that the gap when opened on bottom and top is equal. **If not, loose the set screw and adjust** the lower or upper hinges until the door closes perfectly and the space between the top and the bottom is equal. Fasten the set screw (do not overtighten).

**Ouvrir la porte et vérifier qu'elle se ferme parfaitement. Vérifier également que l'écart lorsqu'il est ouvert en bas et en haut est égal. Sinon, desserrer la vis de réglage et ajuster la charnière inférieure ou supérieure jusqu'à ce que la porte se ferme parfaitement et que l'espace entre le haut et le bas soit égal. Serrer la vis de réglage (ne serrer pas trop).**

*Abrir la puerta y verificar que cierre a la perfección. También verifique que la separación cuando se abre sea igual en la parte inferior y superior. Si no, aflojar el tornillo de fijación y ajustar la bisagra inferior o superior, hasta que la puerta se cierre a la perfección y la brecha en la parte superior e inferior sea igual. Apretar el tornillo de ajuste (no apretar demasiado).*

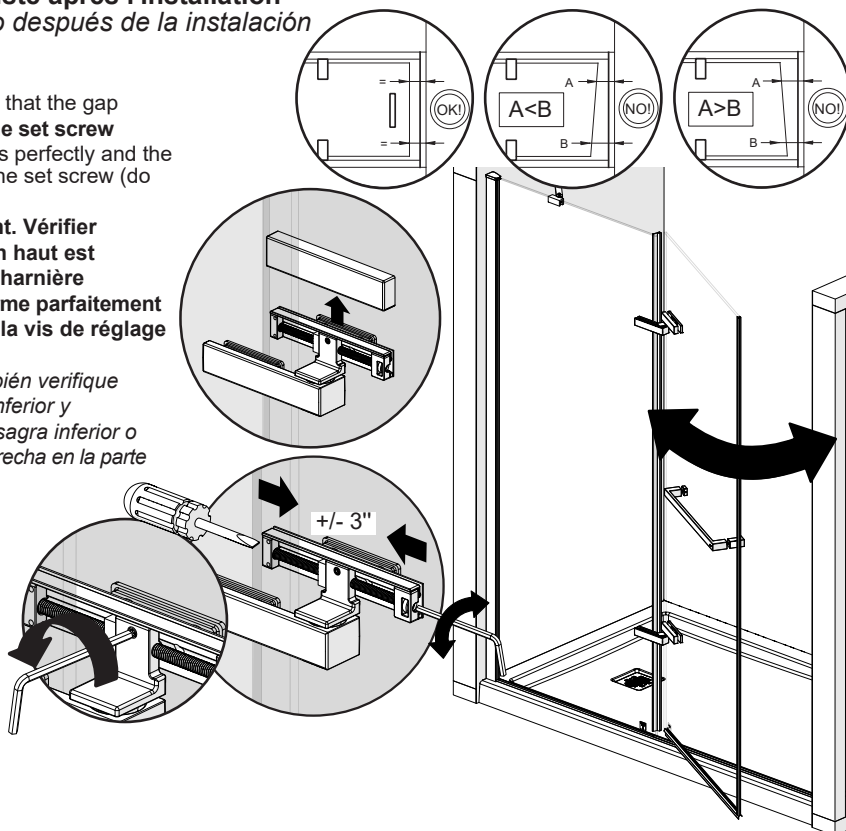

2. Make sure the frame is solid. Fasten any loose screws. **S'assurer que le cadre es solide. Serrer les vis desserrées.**  
*Asegurarse de que el marco este solido. Apretar los tornillos sueltos.*

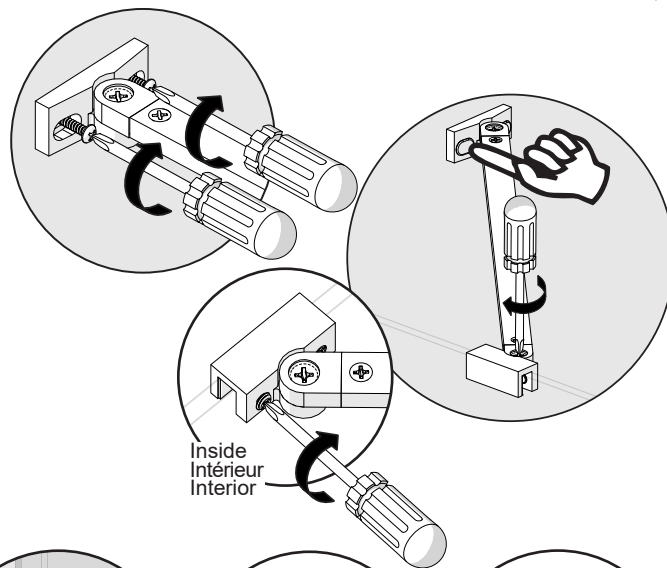

3. Make sure all gaskets and caps are installed. Also that all screw covers are in place and tighten any loose screws (handles, hinges). **S'assurer que tous les joints et les capuchons sont installés. De plus, s'assurer que tous les cache-vis sont en place et serrer les vis desserrées (poignées, charnières).**  
*Asegurarse de que todas las juntas y la tapa del umbral estén instaladas. También que de que todos los cubre tornillos estén en su lugar y apretar los tornillos sueltos (manijas, bisagras).*

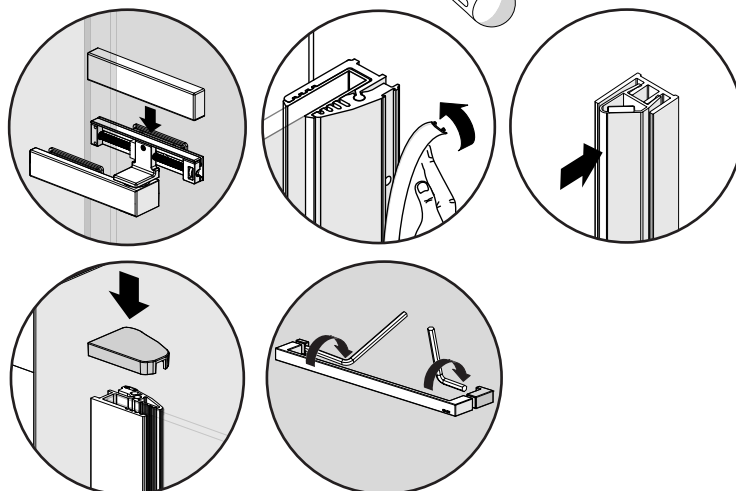

# MAINTENANCE | ENTRETIEN | MANTENIMIENTO

Check me!  
Cochez-moi!  
Marcarme!



Every 6 months  
Chaque 6 mois  
Cada 6 meses

1. Open the door and verify it closes seamlessly. Also verify that the gap when opened on bottom and top is equal. **If not, loose the set screw and adjust** the lower or upper hinges until the door closes perfectly and the space between the top and the bottom is equal. Fasten the set screw (do not overtighten).

**Ouvrir la porte et vérifier qu'elle se ferme parfaitement. Vérifier également que l'écart lorsqu'il est ouvert en bas et en haut est égal. Sinon, desserrer la vis de réglage et ajuster la charnière inférieure ou supérieure jusqu'à ce que la porte se ferme parfaitement et que l'espace entre le haut et le bas soit égal. Serrer la vis de réglage (ne serrer pas trop).**

*Abrir la puerta y verificar que cierre a la perfección. También verifique que la separación cuando se abre sea igual en la parte inferior y superior. Si no, aflojar el tornillo de fijación y ajustar la bisagra inferior o superior. hasta que la puerta se cierre a la perfección y la brecha en la parte superior e inferior sea igual. Apretar el tornillo de ajuste (no apretar demasiado).*

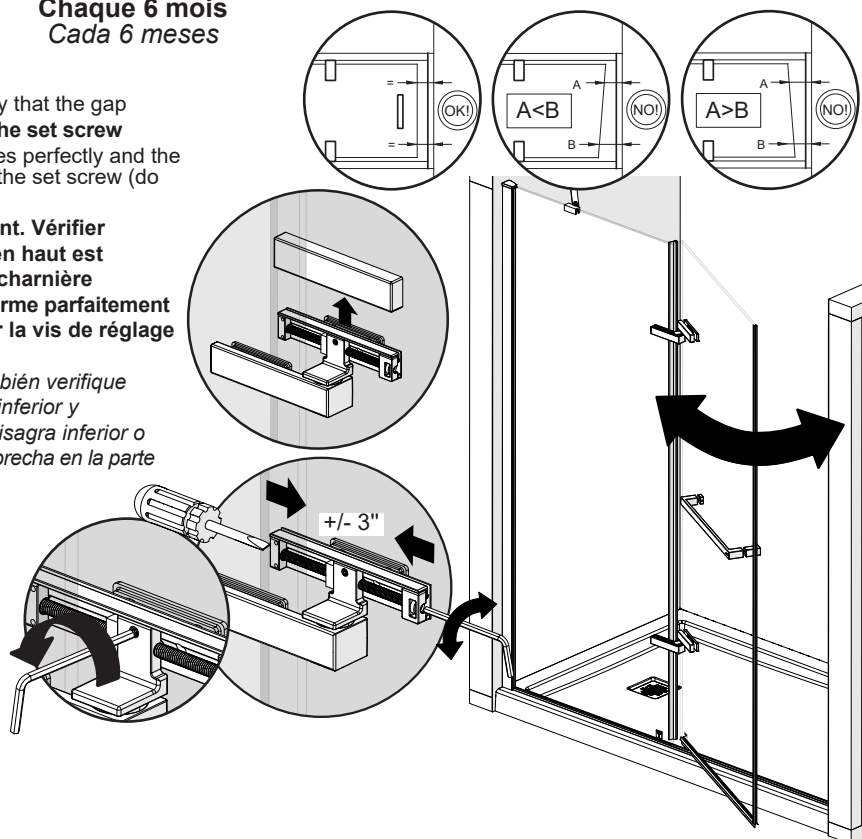

2. Make sure the frame is solid. Fasten any loose screws. **S'assurer que le cadre es solide. Serrer les vis desserrées.**  
*Asegurarse de que el marco este sólido. Apretar los tornillos sueltos.*

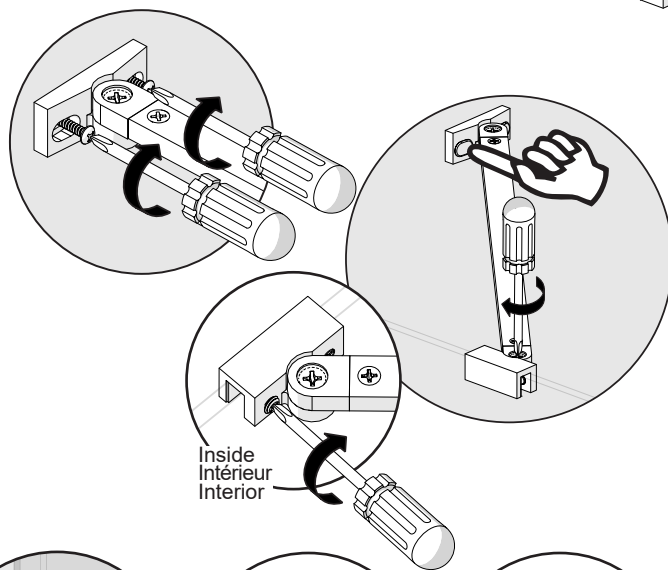

3. Make sure all gaskets and caps are installed. Also that all screw covers are in place and tighten any loose screws (handles, hinges). **S'assurer que tous les joints et les capuchons sont installés. De plus, s'assurer que tous les cache-vis sont en place et serrer les vis desserrées (poignées, charnières).**  
*Asegurarse de que todas las juntas y la tapa del umbral estén instaladas. También que de que todos los cubre tornillos estén en su lugar y apretar los tornillos sueltos (manijas, bisagras).*

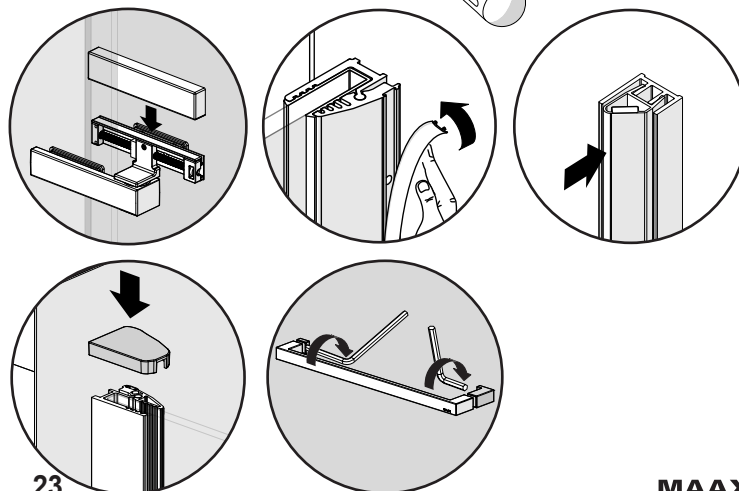

## LIMITED WARRANTY — UNITED STATES

MAAX Bath Inc. offers express limited warranty on each of its products. This warranty extends only to the original owner/end-user for personal household use. For commercial uses, additional limitations apply.

**For accessing product Limited warranty please visit:**

[www.maax.com/us-warranty](http://www.maax.com/us-warranty)

## LIMITED WARRANTY — CANADA

MAAX Bath Inc. offers express limited warranty on each of its products. This warranty extends only to the original owner/end-user for personal household use. For commercial uses, additional limitations apply.

**For accessing product Limited warranty please visit:**

[www.maax.com/ca-warranty](http://www.maax.com/ca-warranty)

## GARANTIE LIMITÉE — CANADA

MAAX Bath Inc. offre une garantie limitée expresse sur chacun de ses produits. Cette garantie s'adresse uniquement au propriétaire/utilisateur original pour un usage personnel domestique. Des restrictions additionnelles s'appliquent aux utilisations commerciales

**Pour accéder à la garantie limitée de votre produit, veuillez consulter le site :**

[www.maax.com/garantie](http://www.maax.com/garantie)

---

# MAAX®

[www.maax.com](http://www.maax.com)

Technical Services / Service technique / Servicio técnico

**T. 1 877 GET-MAAX (1 877 438-6229)**

**F. 1 888 361-2045**

**[www.maax.com](http://www.maax.com)**