

APPLETON PLAY SYSTEM – F24148

INSTALLATION AND OPERATING INSTRUCTIONS

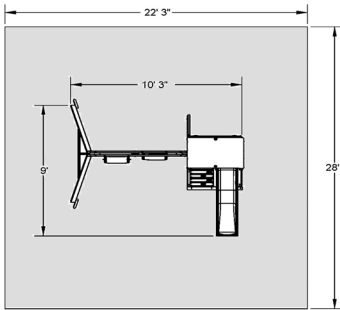

! WARNING To reduce the risk of serious injury or death, you must read and follow these instructions. Keep and refer to these instructions often and give them to any future owner of this play system. Manufacturer contact information provided below.

OBSTACLE FREE SAFETY ZONE - 22'3" x 28' area requires Protective Surfacing. See page 3.

MAXIMUM VERTICAL FALL HEIGHT - 6' (1.8 m)

CAPACITY - 6 Users Maximum, Ages 3 to 10; Weight Limit 110 lbs. (49.9 kg) per child.

RESIDENTIAL HOME USE ONLY. Not intended for public areas such as schools, churches, nurseries, day cares or parks.



4 - 8 Hrs
Two person assembly



Solowave Design

375 Sligo Rd. West, PO Box 10
Mount Forest, ON Canada N0G 2L0

General Inquiries:

8:00am - 4:30pm EST
Toll Free: 1-877-966-3738
support@solowavedesign.com

Table of Contents

Warnings and Safe Play Instructions	pg. 2
Protective Surfacing Guidelines	pg. 3
Instructions for Proper Maintenance	pg. 4
About Our Wood – Limited Warranty	pg. 5
Keys to Assembly Success	pg. 6
Metric Conversion Sheet	pg. 7
Part ID	pg. 8-12
Installation of I.D./Warning Plaque	Final Step

Warnings and Safe Play Instructions



CONTINUOUS ADULT SUPERVISION REQUIRED. Most serious injuries and deaths on playground equipment have occurred while children were unsupervised! Our products are designed to meet mandatory and voluntary safety standards. Complying with all warnings and recommendations in these instructions will reduce the risk of serious or fatal injury to children using this play system. Go over the warnings and safe play instructions regularly with your children and make certain that they understand and follow them. Remember on-site adult supervision is required for children of all ages.



WARNING

SERIOUS HEAD INJURY HAZARD

Installation over concrete, asphalt, dirt, grass, carpet and other hard surface creates a risk of serious injury or death from falls to the ground. Install and maintain shock absorbing material under and around play-set as recommended on page 3 of these instructions.

COLLISION HAZARD

Place play-set on level ground at least 6 feet from any obstruction such as a garage or house, fences, poles, trees, sidewalks, walls, landscape timbers, rocks, pavement, planters, garden borders, overhanging branches, laundry lines, and electrical wires. (See OBSTACLE FREE SAFETY ZONE on cover)

CHOKING HAZARD/SHARP EDGES & POINTS

Adult assembly required. This product contains small parts and parts with sharp edges and points. Keep parts away from children until fully assembled.

WARNING LABEL

Owners shall be responsible for maintaining the legibility of the warning labels.

STRANGULATION HAZARD

- NEVER allow children to play with ropes, clotheslines, pet leashes, cables, chains or cord-like items when using this play-set or to attach these items to play-set.
- NEVER allow children to wear loose fitting clothing, ponchos, hoods, scarves, capes, necklaces, items with draw-strings, cords or ties when using this play-set.
- NEVER allow children to wear bike or sport helmets when using this play-set.

Failure to prohibit these items, even helmets with chin straps, increases the risk of serious injury and death to children from entanglement and strangulation.

TIP OVER HAZARD

Choose a level location for the equipment. This can reduce the likelihood of the play set tipping over and loose-fill surfacing materials washing away during heavy rains.

DO NOT allow children to play on the play-set until the assembly is complete and the unit is properly anchored.



WARNING – Safe Play Instructions

- ✓ Observe capacity limitations of your play-set. See front cover.
- ✓ Dress children with well fitting and full foot enclosing footwear.
- ✓ Teach children to sit with their full weight in the center of the swing seat to prevent erratic swing motion or falling off.
- ✓ Check for splintered, broken or cracked wood; missing, loose, or sharp edged hardware. Replace, tighten and or sand smooth as required prior to playing.
- ✓ Verify that suspended climbing ropes, rope ladders, chain or cable are secured at both ends and cannot be looped back on itself as to create an entanglement hazard.
- ✓ On sunny and or hot days, check the slide and other plastic rides to assure that they are not very hot as to cause burns. Cool hot slide and rides with water and wipe dry prior to using.
- ✗ Do not allow children to wear open toe or heel footwear like sandals, flip-flops or clogs.
- ✗ Do not allow children to walk, in front, between, behind or close to moving rides.
- ✗ Do not let children twist swing chains or ropes or loop them over the top support bar. This may reduce the strength of the chain or rope and cause premature failure.
- ✗ Do not let children get off rides while they are in motion.
- ✗ Do not permit climbing on equipment when it is wet.
- ✗ Do not permit rough play or use of equipment in a manner for which it was not intended. Standing on or jumping from the roof, elevated platforms, swings, climbers, ladders or slide can be dangerous.
- ✗ Do not allow children to swing empty rides or seats.
- ✗ Do not allow children to go down slide head first or run up slide.

⚠️ Protective Surfacing - Reducing Risk of Serious Head Injury From Falls

One of the most important things you can do to reduce the likelihood of serious head injuries is to install shock-absorbing protective surfacing under and around your play equipment. The protective surfacing should be applied to a depth that is suitable for the equipment height in accordance with ASTM F1292. There are different types of surfacing to choose from; whichever product you select, follow these guidelines:

Loose-Fill Materials

- Maintain a minimum depth of 9 inches of loose-fill materials such as wood mulch/chips, engineered wood fiber (EWF), or shredded/recycled rubber mulch for equipment up to 8 feet high; and 9 inches of sand or pea gravel for equipment up to 5 feet high. NOTE: An initial fill level of 12 inches will compress to about a 9-inch depth of surfacing over time. The surfacing will also compact, displace, and settle, and should be periodically raked and refilled to maintain at least a 9-inch depth.
- Use a minimum of 6 inches of protective surfacing for play equipment less than 4 feet in height. If maintained properly, this should be adequate. (At depths less than 6 inches, the protective material is too easily displaced or compacted.)

NOTE: Do not install home playground equipment over concrete, asphalt, or any other hard surface. A fall onto a hard surface can result in serious injury to the equipment user. Grass and dirt are not considered protective surfacing because wear and environmental factors can reduce their shock absorbing effectiveness. Carpeting and thin mats are not adequate protective surfacing. Ground level equipment -- such as a sandbox, activity wall, playhouse or other equipment that has no elevated play surface -- does not need any protective surfacing.

- Use containment, such as digging out around the perimeter and/or lining the perimeter with landscape edging. Don't forget to account for water drainage.
- Periodically rake, check and maintain the depth of the loose-fill surfacing material. Marking the correct depth on the play equipment support posts will help you to see when the material has settled and needs to be raked and or replenished. Be sure to rake and evenly redistribute the surfacing in heavily used areas.
- Do not install loose fill surfacing over hard surfaces such as concrete or asphalt.

Poured-In-Place Surfaces or Pre-Manufactured Rubber Tiles

You may be interested in using surfacing other than loose-fill materials - like rubber tiles or poured-in-place surfaces.

- Installations of these surfaces generally require a professional and are not “do-it yourself” projects.
- Review surface specifications before purchasing this type of surfacing. Ask the installer/manufacturer for a report showing that the product has been tested to the following safety standard: ASTM F1292 *Standard Specification for Impact Attenuation of Surfacing Materials within the Use Zone of Playground Equipment*. This report should show the specific height for which the surface is intended to protect against serious head injury. This height should be equal to or greater than the fall height - vertical distance between a designated play surface (*elevated surface for standing, sitting, or climbing*) and the protective surfacing below - of your play equipment.
- Check the protective surfacing frequently for wear.

Placement

Proper placement and maintenance of protective surfacing is essential. Refer to diagram on front cover. Be sure to;

- Extend surfacing at least 6 feet from the equipment in all directions.
- For to-fro swings, extend protective surfacing in front of and behind the swing to a distance equal to twice the height of the top bar from which the swing is suspended.
- For tire swings, extend surfacing in a circle whose radius is equal to the height of the suspending chain or rope, plus 6 feet in all directions.

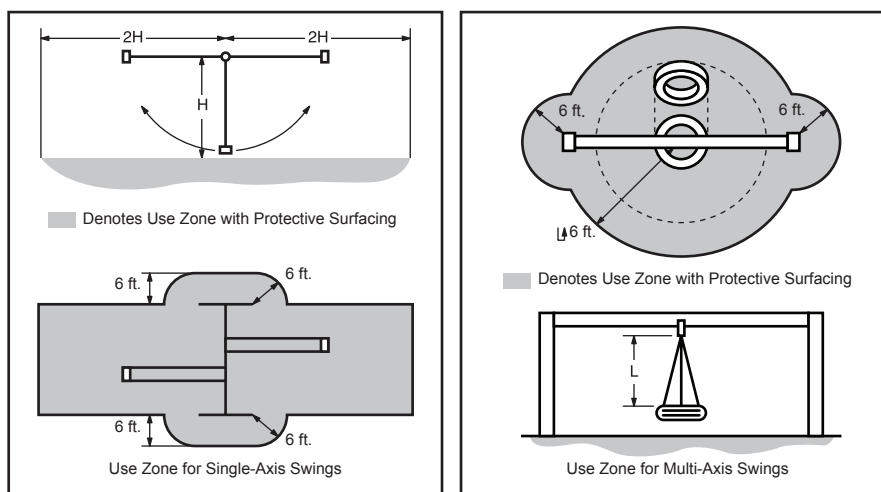

Instructions for Proper Maintenance

Your Big Backyard Play System is designed and constructed of quality materials with your child's safety in mind. As with all outdoor products used by children, it will weather and wear. To maximize the enjoyment, safety and life of your Play Set, it is important that you, the owner, properly maintain it.

Check the following at the beginning of the play season:

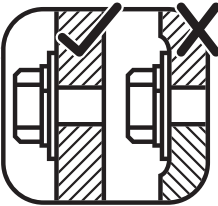
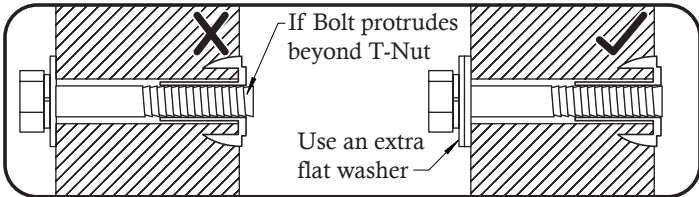
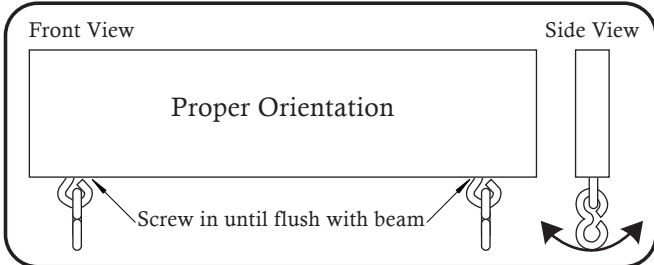
<p>HARDWARE:</p> <ul style="list-style-type: none"> ✓ Check metal parts for rust. If found, sand and repaint using a non-lead paint complying with 16 CFR 1303. ✓ Inspect and tighten all hardware. On wood assemblies DO NOT OVER-TIGHTEN as to cause crushing and splintering of wood. ✓ Check for sharp edges or protruding screw threads, add washers if required.   <p>If Bolt protrudes beyond T-Nut</p> <p>Use an extra flat washer</p> <p>SHOCK ABSORBING SURFACING:</p> <ul style="list-style-type: none"> ✓ Check for foreign objects. Rake and check depth of loose fill protective surfacing materials to prevent compaction and maintain appropriate depth. Replace as necessary. (See Protective Surfacing, page 3) <p>GROUND STAKES (ANCHORS):</p> <ul style="list-style-type: none"> ✓ Check for looseness, damage or deterioration. Should firmly anchor unit to ground during use. Re-secure and or replace, if necessary. 	<p>SWING HANGERS:</p> <ul style="list-style-type: none"> ✓ Check that they are secure and orientated correctly. Hook should rotate freely and perpendicular to support beam. ✓ If squeaking occurs lubricate bushings with oil or WD-40®.  <p>Front View</p> <p>Side View</p> <p>Proper Orientation</p> <p>Screw in until flush with beam</p> <p>SWINGS, ROPES AND RIDES:</p> <ul style="list-style-type: none"> ✓ Reinstall if removed during cold season. Check all moving parts including swing seats, ropes, chains and attachments for wear, rust and other deterioration. Replace as needed. ✓ Check that ropes are tight, secure at both ends and cannot loop back as to create an entrapment. <p>WOOD PARTS:</p> <ul style="list-style-type: none"> ✓ Check all wood members for deterioration, structural damage and splintering. Sand down splinters and replace deteriorated wood members. As with all wood, some checking and small cracks in grain is normal. ✓ Applying a water repellent or stain (water-based) on a yearly basis is important maintenance to maintain maximum life and performance of the product
---	--

Check twice a month during play season:

<p>HARDWARE:</p> <ul style="list-style-type: none"> ✓ Inspect for tightness. Must be firmly against, but not crushing the wood. DO NOT OVER-TIGHTEN. This will cause splintering of wood. ✓ Check for sharp edges or protruding screw threads. Add washers if required. 	<p>SHOCK ABSORBING SURFACING:</p> <ul style="list-style-type: none"> ✓ Rake and check depth of loose fill protective surfacing materials to prevent compaction and maintain appropriate depth. Replace as necessary. (See Protective Surfacing, page 3)
---	---

Check once a month during play season:

<p>SWING HANGERS:</p> <ul style="list-style-type: none"> ✓ Check that they are secure and orientated correctly. Hook should rotate freely and perpendicular to support beam. ✓ If squeaking occurs lubricate bushings with oil or WD-40®. 	<p>SWINGS AND RIDES:</p> <ul style="list-style-type: none"> ✓ Check swing seats, all ropes, chains and attachments for fraying, wear, excessive corrosion or damage. Replace if structurally damaged or deteriorated.
--	---

Check at the end of the play season:

<p>SWINGS AND RIDES:</p> <ul style="list-style-type: none"> ✓ To prolong their life, remove swings and store inside when outside temperature is below 32°F/0°C. Below freezing, plastic parts may become more brittle. 	<p>SHOCK ABSORBING SURFACING:</p> <ul style="list-style-type: none"> ✓ Rake and check depth of loose fill protective surfacing materials to prevent compaction and maintain appropriate depth. Replace as necessary. (See Protective Surfacing, page 3)
--	---

If you dispose of your play set: Please disassemble and dispose of your unit so that it does not create any unreasonable hazards at the time it is discarded. Be sure to follow your local waste ordinances.

About Our Wood

Solowave Design™ uses only premium playset lumber, ensuring the safest product for your children's use. Although great care has been taken in selecting the best quality lumber available, wood is a product of nature and susceptible to weathering (changes in the aesthetics of the wood). A light sanding may be required to remove minor splinters. For your information, we have described some changes that may occur as a result of weathering:

1. **Checking** Checks are surface cracks in the wood along the grain. 4" x 4" material will experience more checking than 2", 1-1/4" or 1" material because the surface and interior moisture content will vary more widely than in thinner wood.
2. **Warping** Warping refers to any distortion (twisting, cupping) from the true plane that may take place during weathering.
3. **Fading** Wood exposed to sunlight, will over time, turn a grey color.

Note: The above changes will not affect the strength of the product.

What causes weathering?

One of the main reasons for weathering is the effects of water (moisture); the moisture content of the wood at the surface is different than the interior of the wood. As the moisture moves in or out of the wood (result of climate changes), the different moisture content causes tension in the wood, which can result in checking and or warping.

How can I reduce the amount of weathering to my Play System?

At the factory we have added water repellent to the stain. This water repellent decreases the amount of water absorption during rain or snow thus decreasing the tension in the wood. Sunlight will break down the water repellent, applying a water repellent or stain on a yearly basis is important maintenance. (see your local stain and paint supplier for a recommended product) Also if storing the product before installation, make sure you store out of direct sunlight in a cool dry place.

Will weathering affect the strength of my Play System?

Most weathering is just the normal result of nature and will not affect safe play and enjoyment for your child. However if you are concerned that a part has experienced a severe weathering problem please call our consumer relations department for further assistance.

Complete and mail registration card to receive important product notifications and assure prompt warranty service.

5 Year Limited Warranty

Solowave Design warrants that this product is free from defect in materials and workmanship for a period of one year from the original date of purchase. In addition, lumber is warranted for 5 years against structural failure due to rot and insect damage. All other parts, such as hardware, swings, rides, accessories, and slides carry a one-year warranty only.

This warranty applies to the original owner and registrant and is non-transferable.

Regular maintenance is required to assure the integrity of your Play System. Failure by the owner to maintain the product according to the maintenance requirements may void this warranty. This warranty does not cover any inspection cost.

This Limited Warranty does not cover:

- Labor for replacement of any defective item(s);
- Incidental or consequential damages;
- Cosmetic defects which do not affect performance or integrity;
- Vandalism; improper use or installation; acts of nature;
- Minor twisting, warping, checking, or any other natural occurring properties of wood that do not affect performance or integrity.

Solowave Design products have been designed for safety and quality. Any modifications made to the original product could damage the structural integrity of the unit leading to failure and possible injury. Solowave Design Inc. cannot assume any responsibility for modified products. Furthermore, modification voids any and all warranties.

This product is warranted for **RESIDENTIAL USE ONLY**. Under no circumstance should a Solowave Design Play System be used in public settings such as schools, churches, playgrounds, parks, day cares and the like.

Such use may lead to product failure and potential injury. Any and all public use will void this warranty.

Solowave Design disclaims all other representations and warranties of any kind, express or implied.

This Warranty gives you specific legal rights. You may have other rights as well which vary from state to state or province to province. This warranty excludes all consequential damages, however, some states do not allow the limitation or exclusion of consequential damages, and therefore this limitation may not apply to you.

Keys to Assembly Success

Tools Required



Part Identification Key

On each page, you will find the parts and quantities required to complete the assembly step illustrated on that page. Here is a sample.

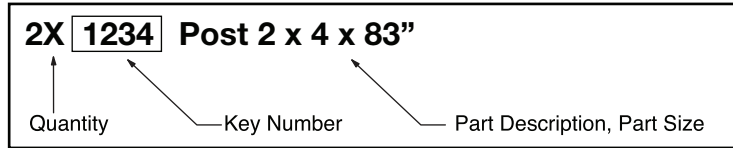

Symbols

Throughout these instructions symbols are provided as important reminders for proper and safe assembly.

<p>This identifies information that requires special attention. Improper assembly could lead to an unsafe or dangerous condition.</p>	<p>Check that set or assembly is properly level before proceeding.</p> <p>Use Level</p>
<p>Use Help</p> <p>Where this is shown, 2 or 3 people are required to safely complete the step. To avoid injury or damage to the assembly make sure to get help!</p>	<p>Pre-drill 1/8\"/> <p>Pre-drill a pilot hole before fastening screw or lag to prevent splitting of wood.</p> </p>
<p>Measure Distance</p> <p>Check that assembly is square before tightening bolts.</p> <p>Use a measuring tape to assure proper location.</p>	<p>Tighten Bolts</p> <p>This indicates time to tighten bolts, but not too tight! Do not crush the wood. This may create splinters and cause structural damage.</p>
<p>Square Assembly</p>	

CAUTION – Protrusion Hazard

Once the assembly is tightened, watch for exposed threads. If a thread protrudes from the T-Nut, remove the bolt and add washers to eliminate this condition. Extra washers have been provided for this purpose.

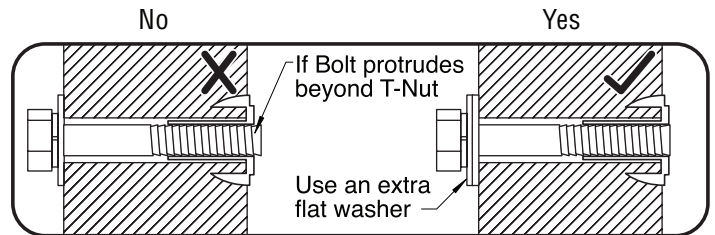

Proper Hardware Assembly

Lag screws require drilling pilot holes to avoid splitting wood. Only a flat washer is required. For ease of installation liquid soap can be used on all lag-type screws.

For bolts, tap T-Nut into hole with hammer. Insert the hex bolt through lock washer first then flat washer then hole. Because the assemblies need to be squared do not completely tighten until instructed. Pay close attention to diameter of the bolts. 5/16\"/>

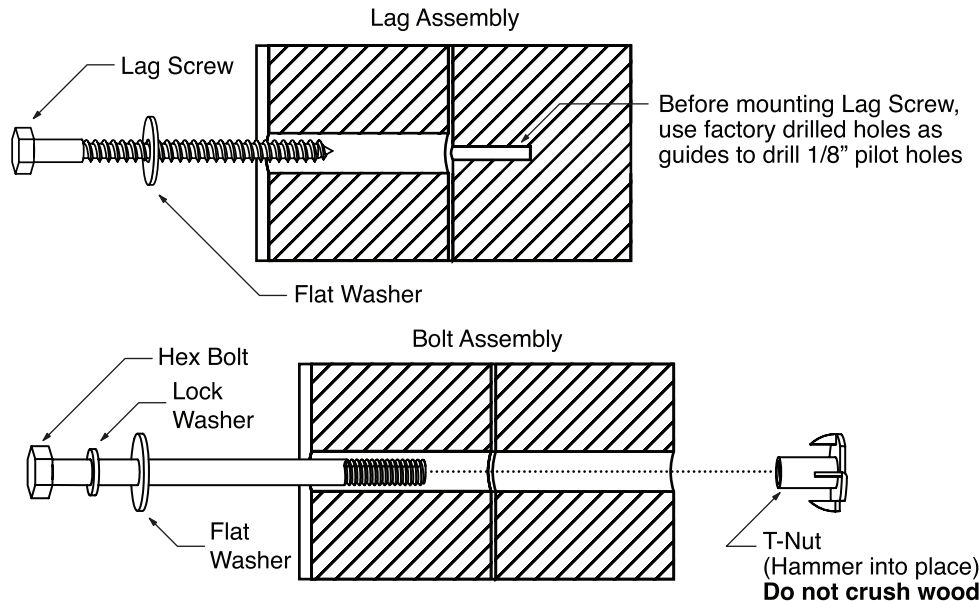

SOLOWAVE DESIGN HARDWARE

5/16"(.31) = 8mm Hex Bolt

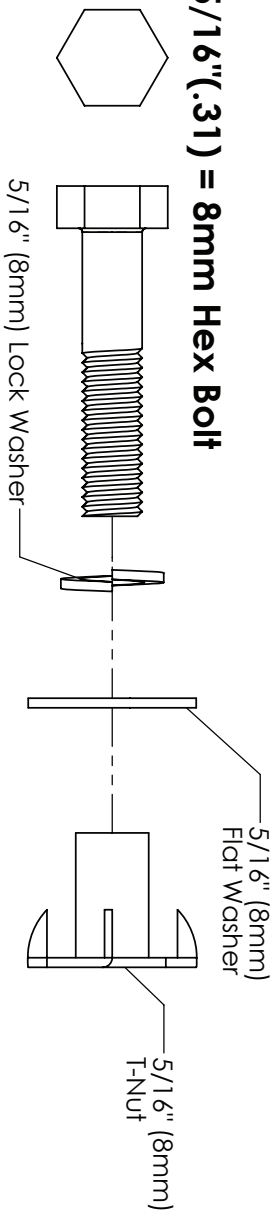

1/4"(0.25) = 6mm Hex Bolt

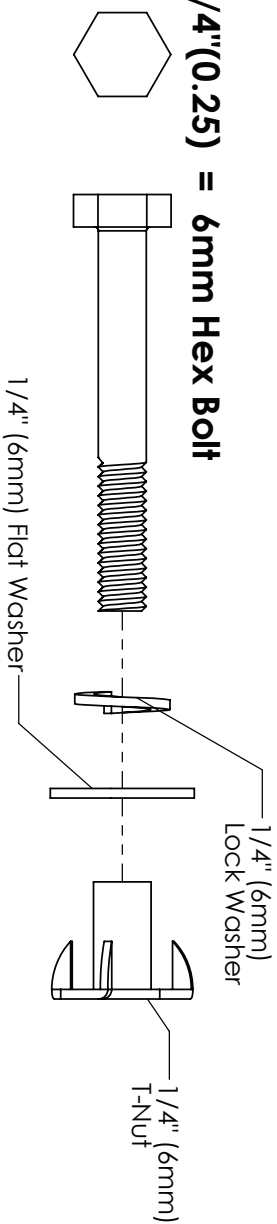

1/4"(0.25) = 6mm Lag Screw

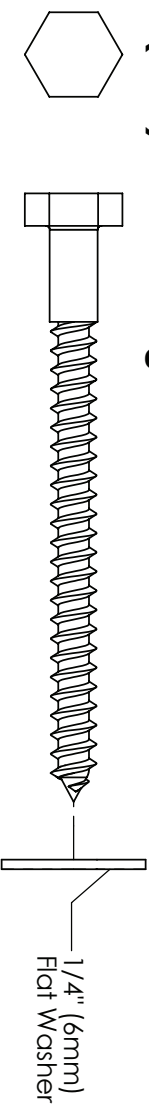

5/16"(.31) = 8mm Lag Screw

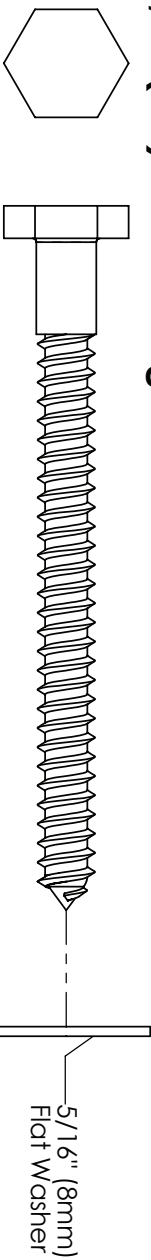

3/8"(.38) = 9.5mm Lag Screw

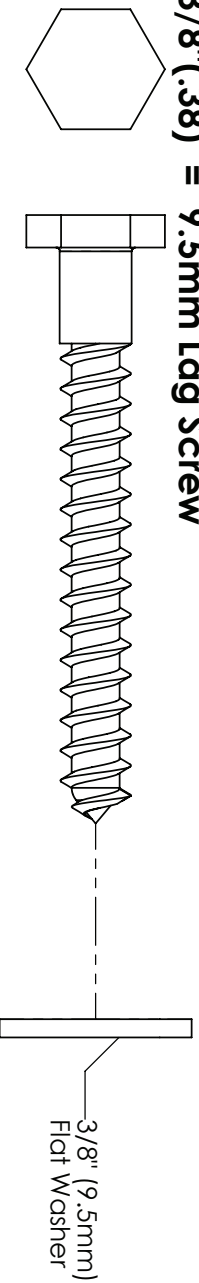

HARDWARE LENGTH CHART inches vs millimetres

6	152
5 1/2	140
5	127
4 1/2	114
4	102
3 1/2	89
3	76
2 1/2	64
2	51
1 1/2	38
1 1/4	32
1-1/8	29
1	25.4
7/8	22
3/4	19
1/2	12.7

DIAMETER CONVERSION

1 inch = 25.4mm

For example:

BOLT DIAMETER 5/16 (0.31) inches

0.31 inches x 25.4mm = 8mm

LENGTH CONVERSION

1 inch = 25.4mm

For example:

BOLT LENGTH 4 1/2 (4.5) inches long

4.5 inches x 25.4mm = 114mm long

Part Identification (Reduced Size)

(4) CE Floor Board 1 x 4 x 32-1/2"



(1) CE Sw Beam - Back 2 x 6 x 69-1/2"



(1) CE Sw Beam - Front 2 x 6 x 69-1/2"



(2) CE Gap Board 1 x 6 x 23-1/2"

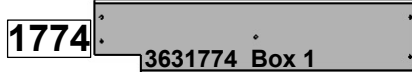

(5) Floor Board 1 x 6 x 23-1/2"

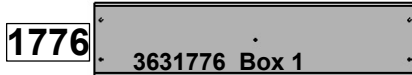

(2) CE Rock Board B 1 x 6 x 17"

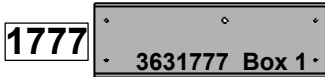

(2) CE Rock Board A 1 x 6 x 17"

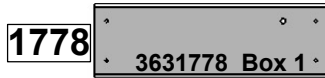

(1) CE Access Board 1 x 6 x 17"



(1) Gusset 2 x 3 x 16"



(2) Front Divider 1 x 4 x 38"

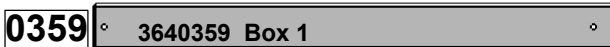

(1) Lower Diagonal 2 x 3 x 37"



(2) Side Top 1 x 4 x 51-1/2"



(2) Sw Post 2 x 4 x 79-1/2"



WOOD CHART	
Nominal Size	Actual Size
2" x 6"	1 1/2" x 5 3/8"
2" x 4"	1 3/8" x 3 3/8"
2" x 3"	1 3/8" x 2 1/2"
2" x 2"	1 1/2" x 1 1/2"
5/4" x 4"	1" x 3 1/2"
5/4" x 5"	1" x 4 1/2"
5/4" x 6"	1" x 5 1/2"
1" x 6"	5/8" x 5 3/8"
1" x 5"	5/8" x 4 1/2"
1" x 4"	5/8" x 3 3/8"
1" x 2"	5/8" x 1 3/8"

Part Identification (Reduced Part Size)

WOOD CHART	
Nominal Size	Actual Size
2" x 6"	1½" x 5⅝"
2" x 4"	1⅜" x 3⅜"
2" x 3"	1⅜" x 2½"
2" x 2"	1½" x 1½"
5/4" x 4"	1" x 3½"
5/4" x 5"	1" x 4½"
5/4" x 6"	1" x 5½"
1" x 6"	5/8" x 5⅝"
1" x 5"	5/8" x 4½"
1" x 4"	5/8" x 3⅜"
1" x 2"	5/8" x 1⅜"

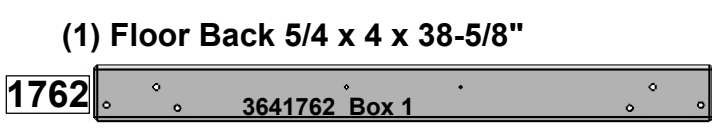
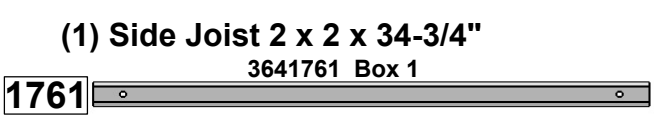
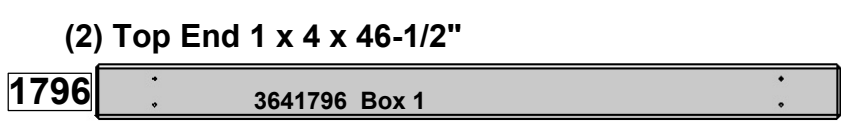
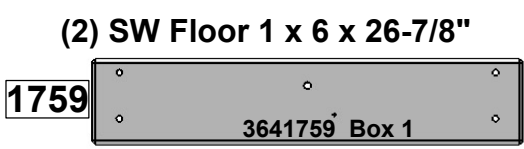
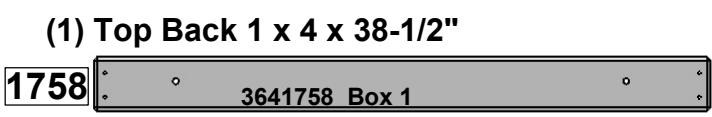
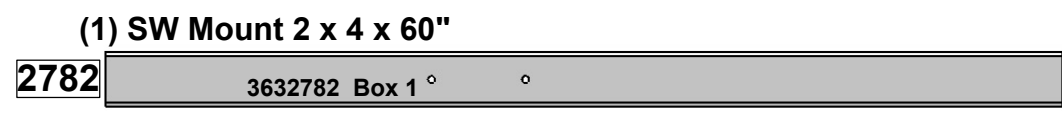
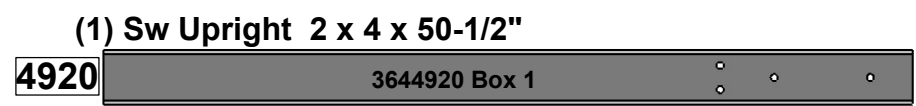
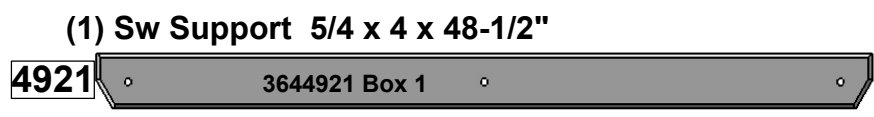
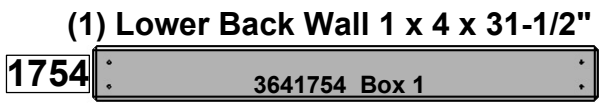
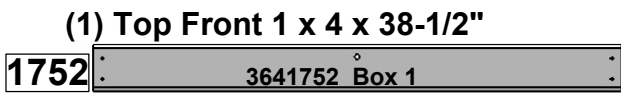
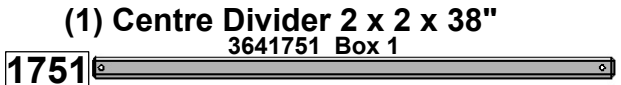
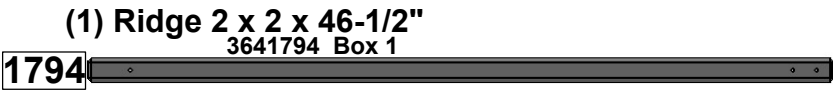

Part Identification (Reduced Part Size)

(1) Floor Joist 5/4 x 2 x 38-1/2"
3641763 Box 1



(1) Floor Front 2 x 3 x 38-1/2"
3641764 Box 1



(2) Rock Rail 2 x 3 x 42-3/4"
3641765 Box 1



(3) Corner Block 2 x 3 x 4-1/2"



(1) Lower Front 1 x 6 x 39-3/4"



(1) Lower Back 1 x 5 x 38-1/2"

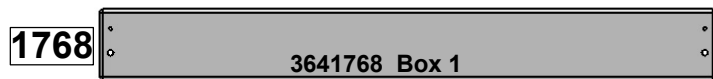

(1) Ground Side 1 x 5 x 42-1/4"

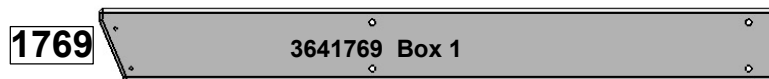

(1) SW Ground 1 x 5 x 60-1/4"



(4) Post 2 x 4 x 74"



(1) Sw Rail Block 2 x 4 x 5-3/8"



(4) Ground Stake 1-1/4 x 1-1/2 x 14"

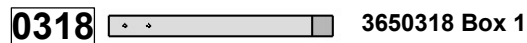

1X 3750703
Inglewood Canopy



1X 3750704
Pine Ridge Chalk Wall

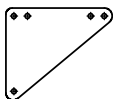

1X 3200184
Triangle Plate (4pk)
Green

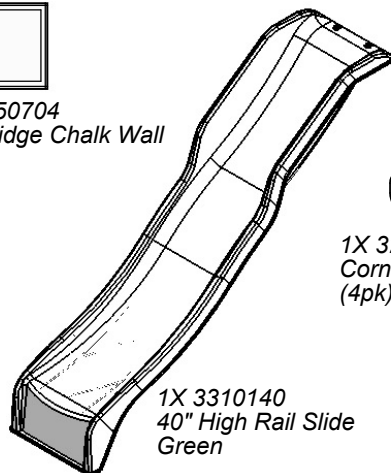

1X 3310140
40" High Rail Slide
Green



1X 3201103
Corner Brace Set
(4pk)

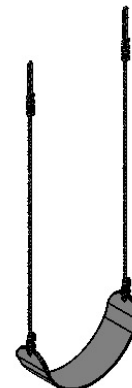

2X 3724943
42" Belt Swing
w/ Welded Chain



1X 3320184 Rocks (4pk)
Green



1X 3320356
Big Backyard ID
Plaque

Hardware Identification (Actual Size)

(13) **LW2** - 5/16" Lock Washer - (9253300)

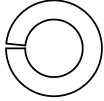

(43) **FW1** - 1/4" Flat Washer - (9251200)

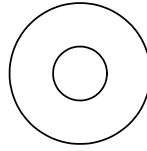

(40) **TN1** - 1/4" T - Nut -(9285200)

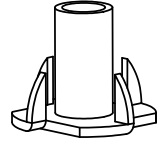

(44) **LW1** - 1/4" Lock Washer - (9253200)



(17) **FW2** - 5/16" Flat Washer - (9251300)

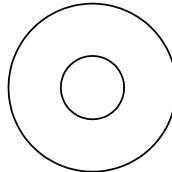

(13) **TN2** - 5/16" T- Nut - (9285300)

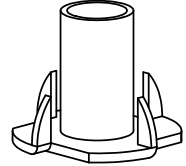

(24) **FW3** - #8 Flat Washer - (9251500)



(2) **LN2** - 5/16" Lock Nut - (9283300)

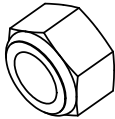

(16) **FW0** - 3/16" Flat Washer - (9251100)

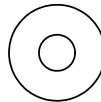

(4) **BN1** - 1/4" Barrel Nut - (9248200)

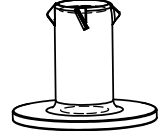

(4) **S10** - Pan Screw #8 x 1" - (9264510)

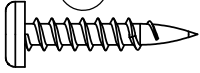

(20) **S1** - Wood Screw #8 x 1-1/8" - (52042514)



(6) **PB2** - Pan Bolt 1/4 x 1-1/4" - (9274211)

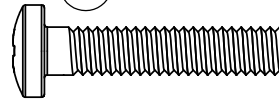

(71) **S2** - Wood Screw #8 x 1-1/2" - (52042512)



(40) **S5** - Pan Screw #8 x 1/2" - (9264504)

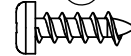

(10) **S15** - Wood Screw #8 x 1-3/4" - (52042513)



(14) **S7** - Pan Screw #12 x 2" - (9264620)

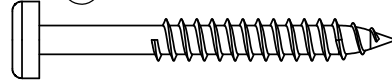

(15) **S3** - Wood Screw #8 x 2-1/2" - (52042522)



(6) **S4** - Wood Screw #8 x 3" - (52042530)

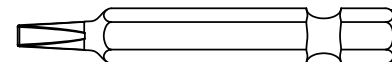

2x2 Robertson Driver - (9200014)

Hardware Identification (Actual Size)

(3) **LS3** - Lag Screw 1/4 x 3" - (9262230)

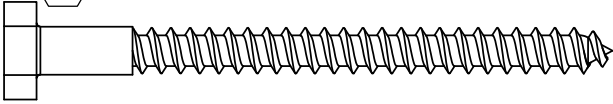

(2) **H1** - Hex Bolt 1/4 x 1-1/2" - (9277212)

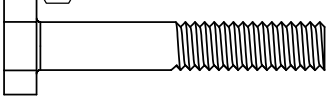

(24) **H2** - Hex Bolt 1/4 x 2" - (9277220)

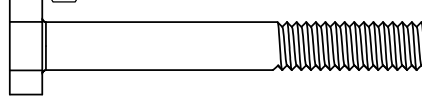

(2) **H3** - Hex Bolt 1/4 x 2-1/2" - (9277222)

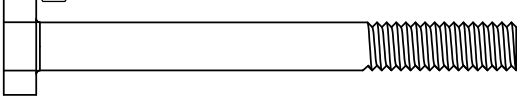

(1) **H11** - Hex Bolt 1/4 x 2-3/4" - (9277223)

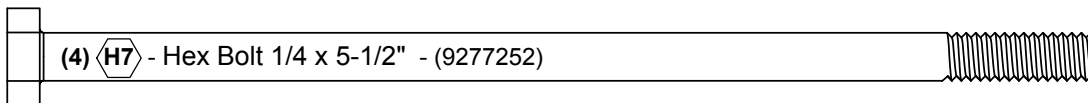
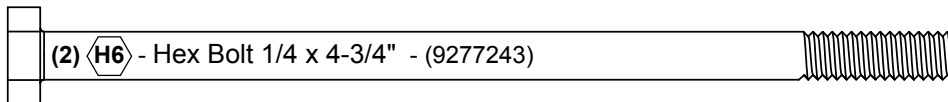
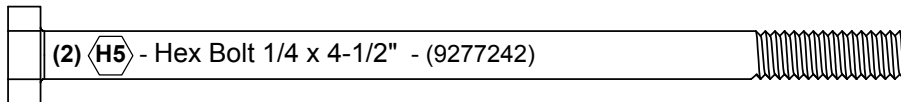
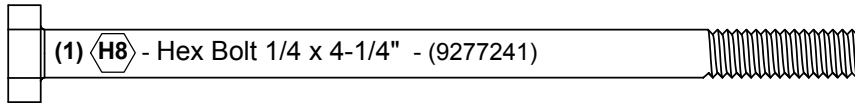
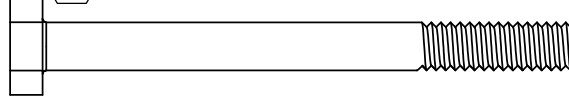

(4) **G1** - Hex Bolt 5/16 x 1-1/2" - (9277312)

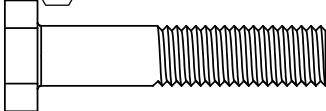

(2) **G8** - Hex Bolt 5/16 x 2" - (9277320)

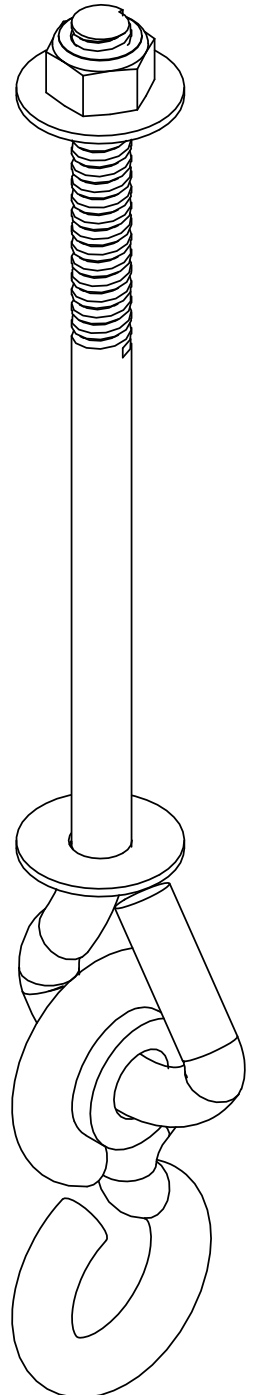
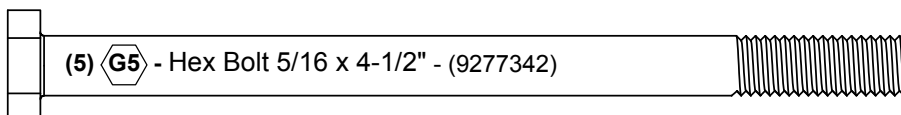
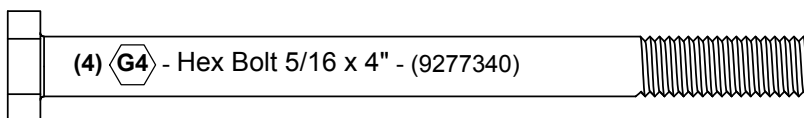
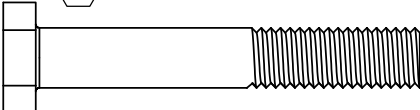

(1) Swing Hanger Bolt Thru (4Pk) - (3202000)

Step 1: Inventory Parts - Read This Before Starting Assembly

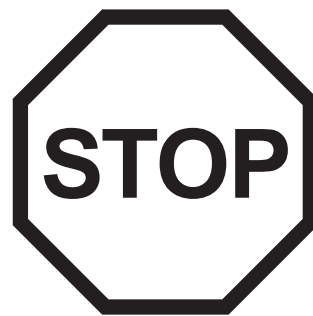
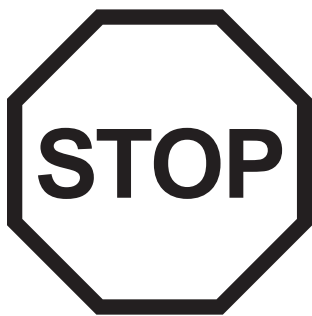

- A.** This is the time for you to inventory all your hardware, wood and accessories, referencing the parts identification sheets. This will assist you with your assembly.
- The wood pieces will have the four digit key number stamped on the ends of the boards. The wood pieces are referenced throughout the instructions with this number.
 - Please refer to Page 6 for proper hardware assembly.
 - Each step indicates which bolts and/or screws you will need for assembly, as well as any flat washers, lock washers, t-nuts or lock nuts.
- B.** If there are any missing or damaged pieces or you need assistance with assembly please contact the Consumer Relations Department directly. Call us before going back to the store.

1-877-966-3738
support@solowavedesign.com

- C.** Read the assembly manual completely, paying special attention to ANSI warnings; notes; and safety/maintenance information on pages 1 - 6.
- D.** Before you discard your cartons fill out the form below.
- The carton I.D. stamp is located on the end of each carton. The tracking number is located on the Big Backyard ID Plaque (3320356).
 - Please retain this information for future reference. You will need this information if you contact the Consumer Relations Department.

MODEL NUMBER: **F24148**

CARTON I.D. STAMP: _ _ _ _ 14459 _ (Box 1)

CARTON I.D. STAMP: _ _ _ _ 14459 _ (Box 4)

CARTON I.D. STAMP: _ _ _ _ 14459 _ (Box 2)

CARTON I.D. STAMP: _ _ _ _ 14459 _ (Box 5)

CARTON I.D. STAMP: _ _ _ _ 14459 _ (Box 3)

CARTON I.D. STAMP: _ _ _ _ 14459 _ (Box 6)

TRACKING NUMBER (from ID Plaque): _____

Step 1: Swing Beam Assembly



Fig. 1.3

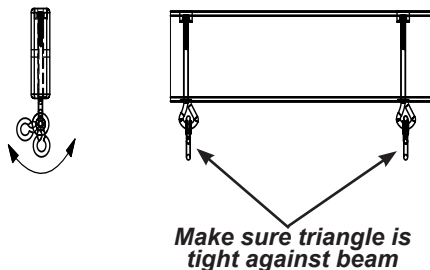

Warning: For your child's safety, orientate the swing hangers as shown to ensure your swing will have proper swing motion when installed. Failure to do so could result in premature failure of the swing hanger or swing chain.

A: In the middle holes of (1772) CE SW Beam Back install 2 Bolt Thru Swing Hangers making sure the swing hangers are oriented in the direction shown in fig. 1.3 to maintain proper swing motion.

B: In the end holes of (1773) CE SW Beam Front install 2 Bolt-Thru Swing Hangers making sure the swing hangers are oriented in the direction shown in fig. 1.3 to maintain proper swing motion.

C: Attach 1 (H7) 1/4 x 5-1/2" Hex Bolt (with lock washer, flat washer and t-nut) to the ends of each (1772) CE SW Beam Back and (1773) CE SW Beam Front. The bolts do not attach to anything, but **MUST** be installed to the beams to prevent splitting and checking of wood. (fig. 1.1)

Fig. 1.1

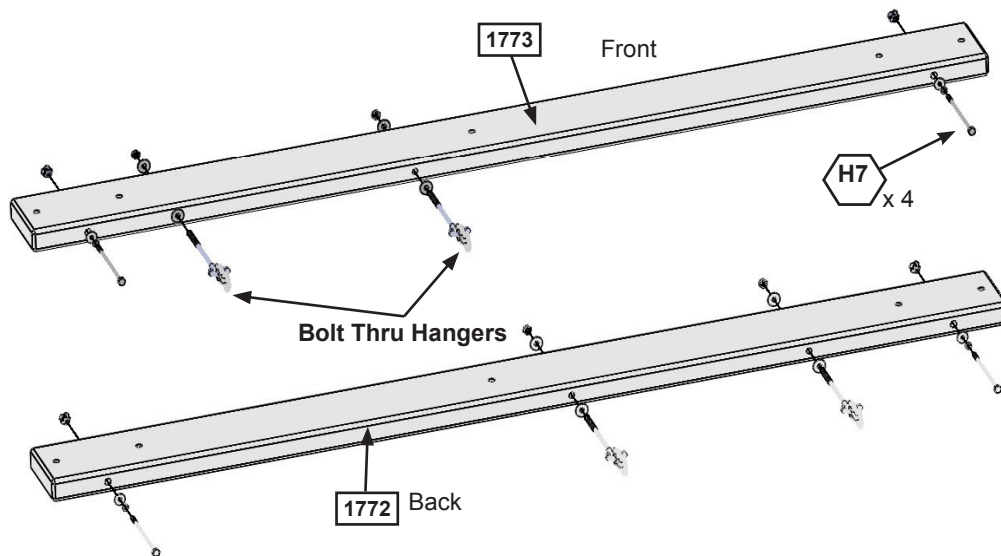

D: Attach 1 Triangle Plate to each end of both the (1773) CE SW Beam Front and (1772) CE SW Beam Back using 1 (G1) 5/16 x 1-1/2" Hex Bolt (with lock washer, flat washer and t-nut) per Triangle Plate in the hole indicated in fig. 1.2. **Correct hole usage is very important.** Refer to fig 1.2 for correct placement of Hex Bolts.

Fig. 1.2

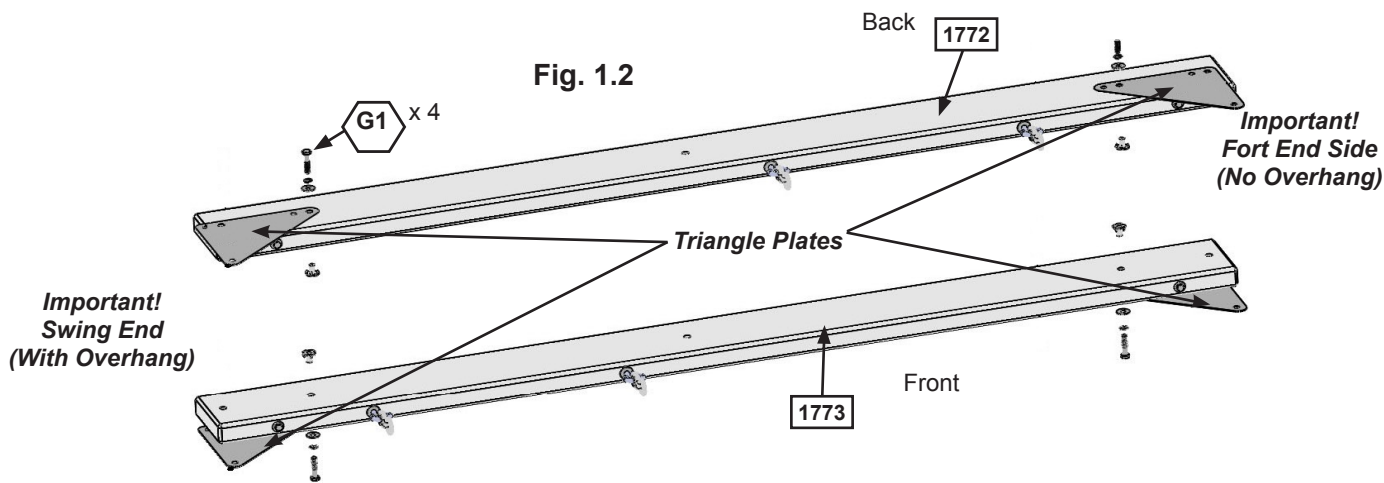

Wood Parts

- 1 x 1773 CE SW Beam Front 2 x 6 x 69-1/2"
- 1 x 1772 CE SW Beam Back 2 x 6 x 69-1/2"

Hardware

- 4 x G1 5/16 x 1-1/2" Hex Bolt (5/16" lock washer, 5/16" flat washer and 5/16" t-nut)
- 4 x H7 1/4 x 5-1/2" Hex Bolt (1/4" lock washer, 1/4" flat washer and 1/4" t-nut)

Other Parts

- 4 x Bolt Thru Swing Hangers
- 1 x Triangle Plates (pkg of 4)

Step 2: Swing End Assembly



A: Attach 2 (2803) SW Posts to (4920) SW Upright using 2 (G4) 5/16 x 4" Hex Bolts (with lock washer, flat washer and t-nut). (fig. 2.1)

B: Attach (4921) SW Support to both (2803) SW Posts and (4920) SW Upright using 3 (G5) 5/16 x 4-1/2" Hex Bolts (with lock washer, flat washer and t-nut). (fig. 2.1)

Fig 2.1

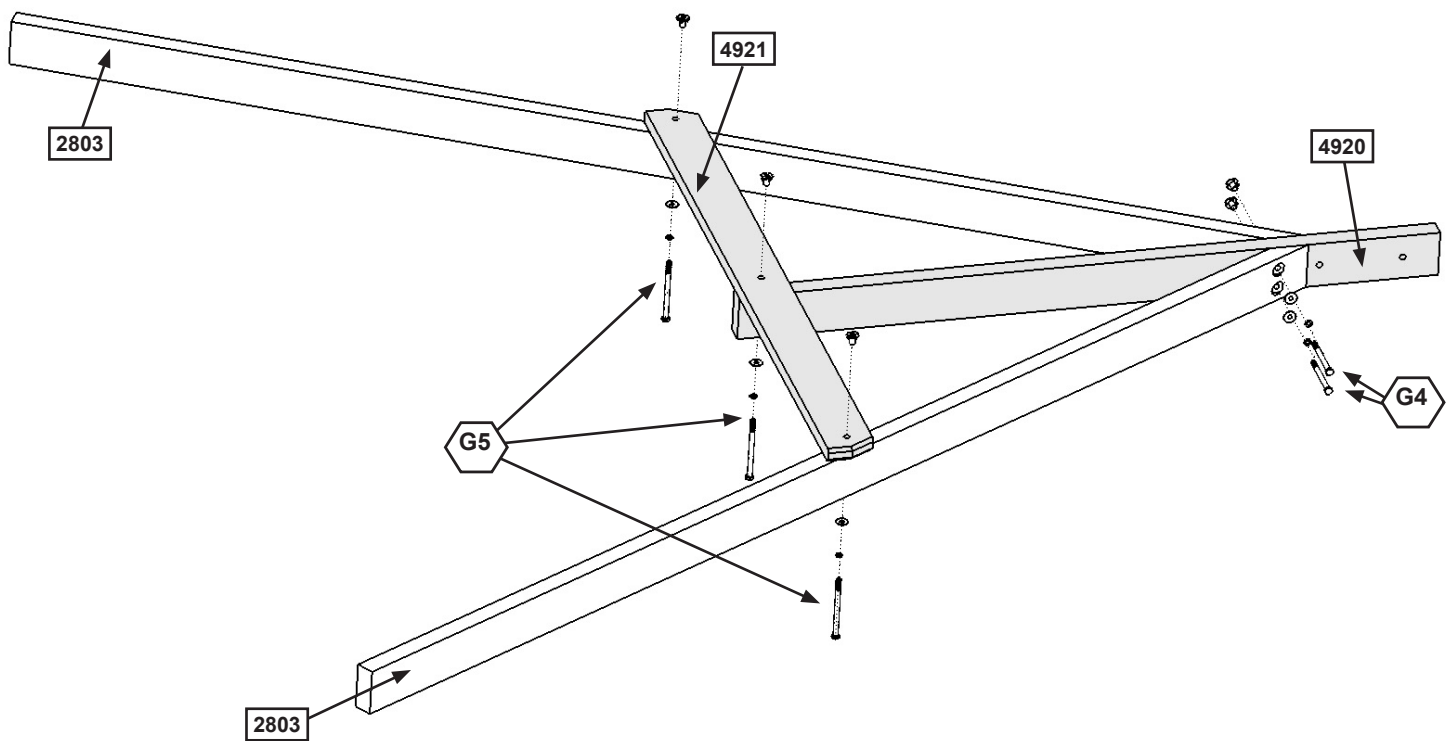

Wood Parts

- 2 x SW Post 2 x 4 x 79-1/2"
- 1 x SW Upright 2 x 4 x 50-1/2"
- 1 x SW Support 5/4 x 4 x 48-1/2"

Hardware

- 2 x 5/16 x 4" Hex Bolt
(5/16" lock washer, 5/16" flat washer, and 5/16" t-nut)
- 3 x 5/16 x 4-1/2" Hex Bolt
(5/16" lock washer, 5/16" flat washer, and 5/16" t-nut)

Step 3: Swing Beam

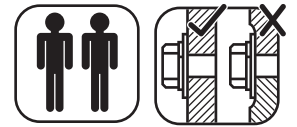

A: Place (4919) SW Rail Block in the centre between (1773) CE SW Beam Front and (1772) CE SW Beam Back and attach beams with 1 (H8) 1/4 x 4-1/4" Hex Bolt (with flat washer, lock washer and t-nut). (fig. 3.1 & 3.2)

B: Attach Swing Beam Assembly to the side of the Swing End Assembly with the overhang (fig. 3.3) using 1 (G5) 5/16 x 4-1/2" Hex Bolt (with lock washer, flat washer and t-nut) in the top hole of Triangle Plate and 1 (G8) 5/16 x 2" Hex Bolt (with 2 flat washers and lock nut) in the bottom hole of Triangle Plate. (fig. 3.3) Make sure Swing End Assembly flares out at an angle. (fig 3.4)

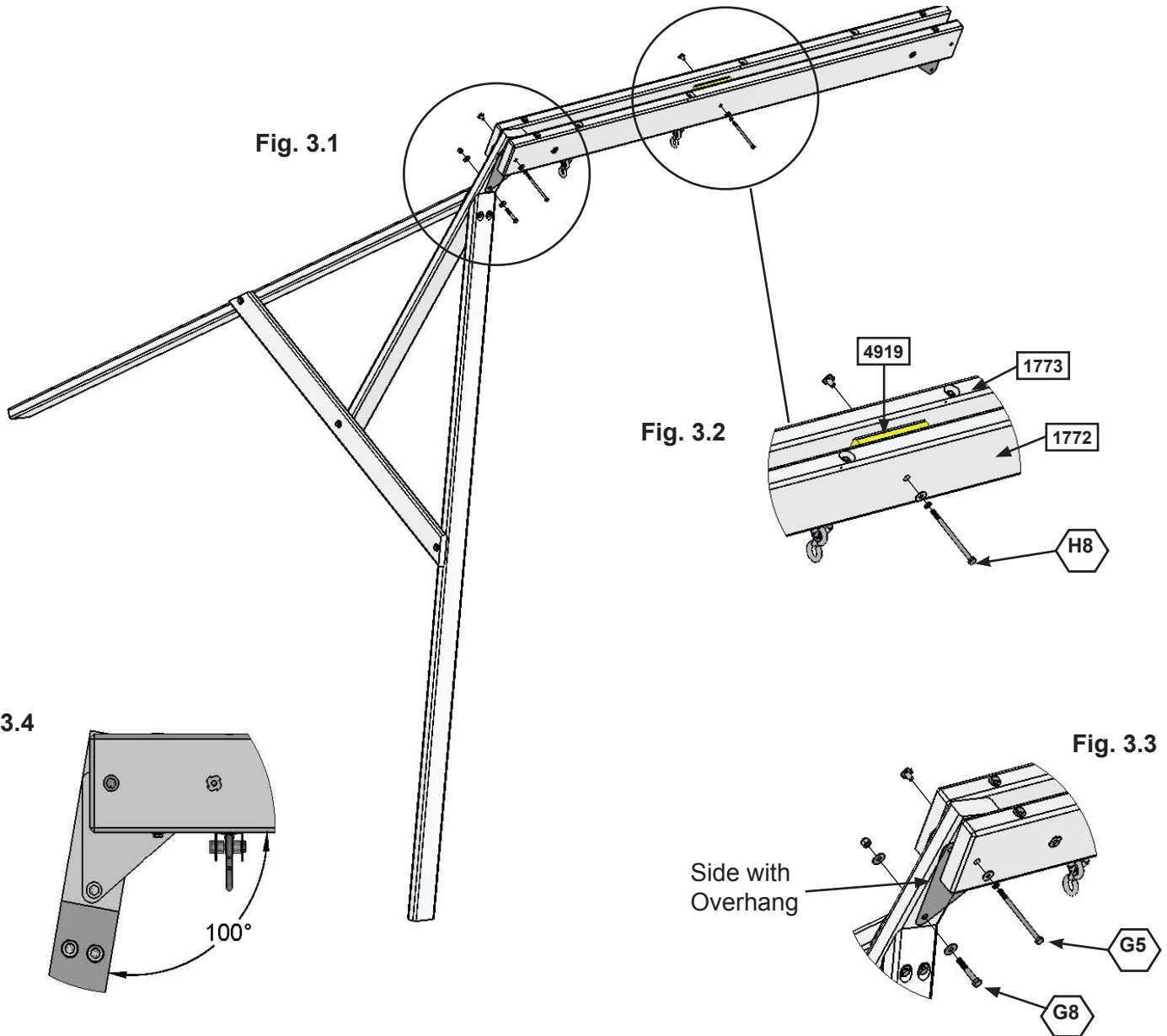

Wood Parts

1 x (4919) SW Rail Block 2 x 4 x 5-3/8"

Hardware

- 1 x (H8) 1/4 x 4-1/4" Hex Bolt (1/4" lock washer, 1/4" flat washer, 1/4" t-nut)
- 1 x (G5) 5/16 x 4-1/2" Hex Bolt (5/16" lock washer, 5/16" flat washer, 5/16" t-nut)
- 1 x (G8) 5/16 x 2" Hex Bolt (5/16" flat washer x 2, 5/16" lock nut)

Step 4: Swing Side Assembly

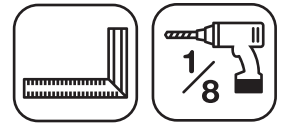

Note: Pre-drill all holes using a 1/8" drill bit before installing the lag screws.

A: To 2 (1771) Posts attach (1770) SW Ground and (1759) SW Floor using 4 (H2) 1/4 x 2" Hex Bolts (with lock washer, flat washer and t-nut) in each board. **Be sure to keep bolts loose.** (fig. 4.1)

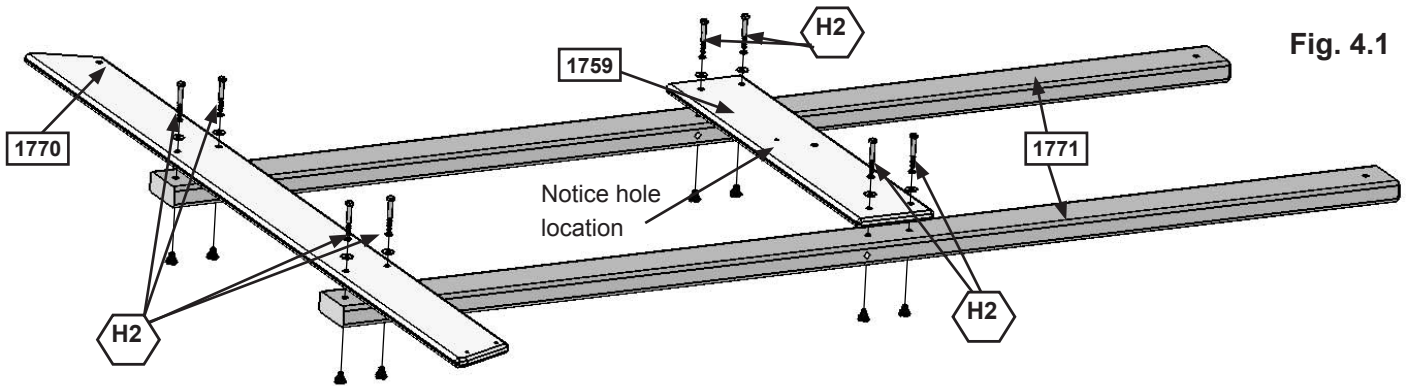

Fig. 4.1

B: Attach (1797) Side Top to each (1771) Post with 2 (H2) 1/4 x 2" Hex Bolts (with lock washer, flat washer and t-nut) Hex Bolts are to be installed from the back of the assembly. **Be sure to keep bolts loose.** (fig. 4.2)

C: Make sure assembly is square and then fasten (0369) Lower Diagonal to (1770) SW Ground at an angle using 1 (H2) 1/4 x 2" Hex Bolt (with lock washer, flat washer and t-nut) and to (1771) Post using 1 (LS3) 1/4 x 3" Lag Screw (with flat washer). (fig 4.2).

D: Attach (2782) SW Mount to (1759) SW Floor and (1797) Side Top with 2 (G4) 5/16 x 4" Hex Bolts (with lock washer, flat washer and t-nut). (fig. 4.2)

E: Tighten all bolts then attach (1797) Side Top to each (1771) Post with 1 (S2) #8 x 1-1/2" Wood Screw per post. (fig. 4.2)

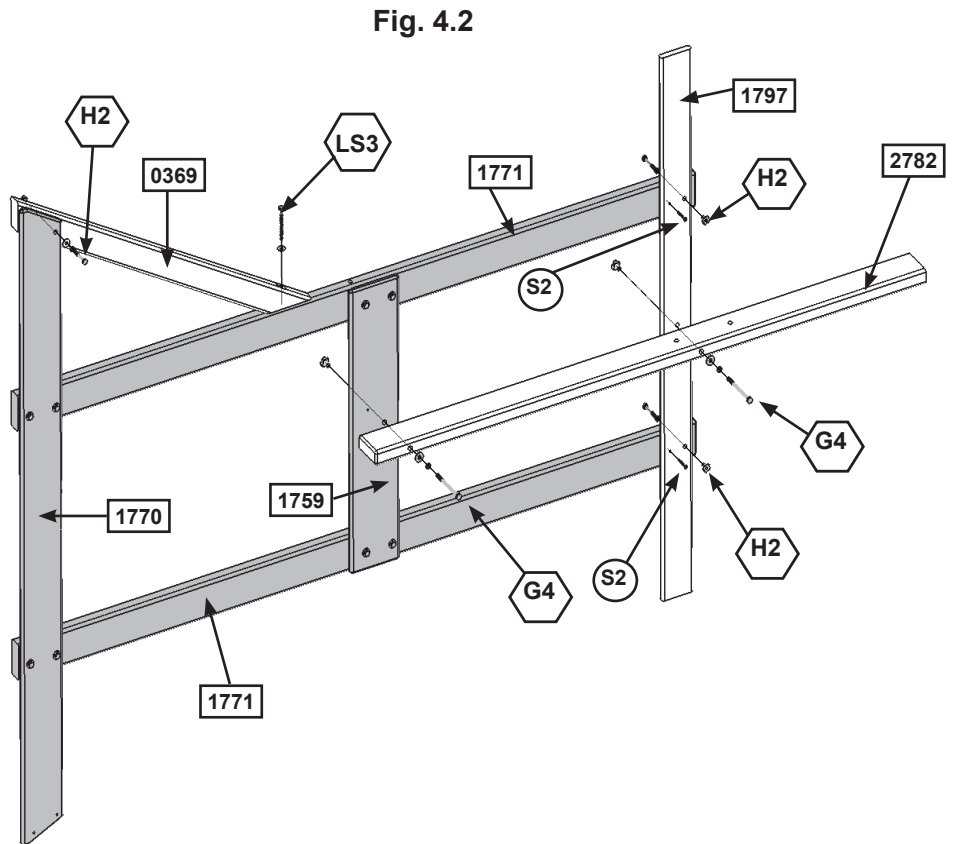

Fig. 4.2

Wood Parts

2 x	1771	Post 2 x 4 x 74"	1 x	1797	Side Top 1 x 4 x 51-1/2"
1 x	1770	SW Ground 1 x 5 x 60-1/4"			
1 x	1759	SW Floor 1 x 6 x 26-7/8"			
1 x	0369	Lower Diagonal 2 x 3 x 37"			
1 x	2782	SW Mount 2 x 4 x 60"			

Hardware

11 x	H2	1/4 x 2" Hex Bolt (1/4" lock washer, 1/4" flat washer, 1/4" t-nut)
2 x	G4	5/16 x 4" Hex Bolt (5/16" lock washer, 5/16" flat washer, 5/16" t-nut)
1 x	LS3	1/4 x 3" Lag Screw (with 1/4" flat washer)
2 x	S2	#8 x 1-1/2" Wood Screw



Step 5: Wall Side Assembly

A: To 2 (1771) Posts loosely attach (1759) SW Floor and (1769) Ground Side with 4 (H2) 1/4 x 2" Bolts (with lock washer, flat washer and t-nut) per board. (fig. 5.1)

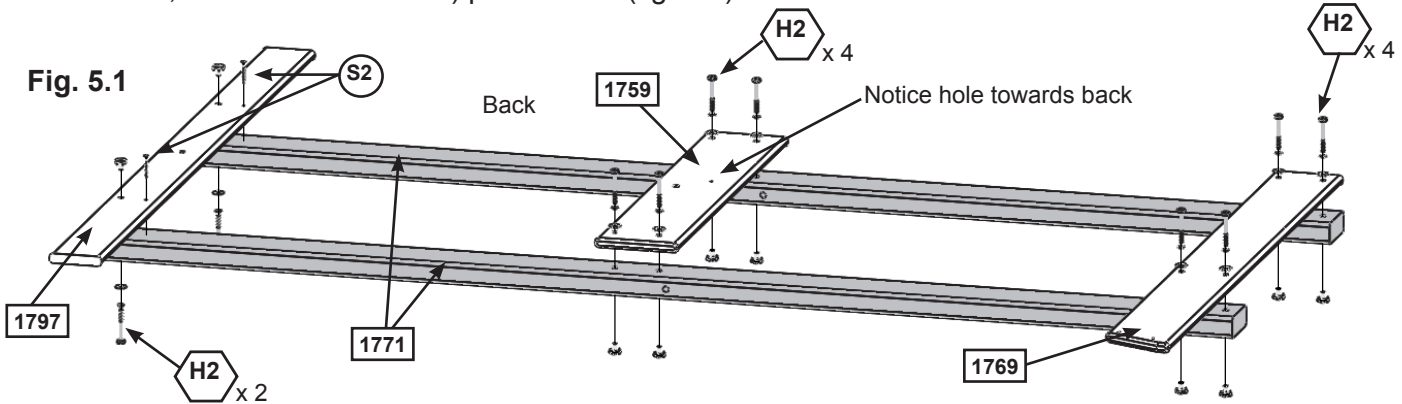

B: Loosely attach (1797) Side Top to each (1771) Post with 2 (H2) 1/4 x 2" Hex Bolts (with lock washer, flat washer and t-nut). These Hex Bolts are to be installed from the back of the assembly. (fig. 5.1)

C: Attach (2783) Tarp Upright to (1759) SW Floor and (1797) Side Top with 2 (H2) 1/4 x 2" Hex Bolts (with lock washer, flat washer and t-nut). Tighten all bolts and attach (1797) Side Top to each (1771) Post with 1 (S2) #8 x 1-1/2" Wood Screw per post. (fig. 5.1 and 5.2)

D: Attach (1766) Corner Block flush to angled extension of (1769) Ground Side with 2 (S2) 8 x 1-1/2" Wood Screws as shown in fig. 5.2 and 5.3.

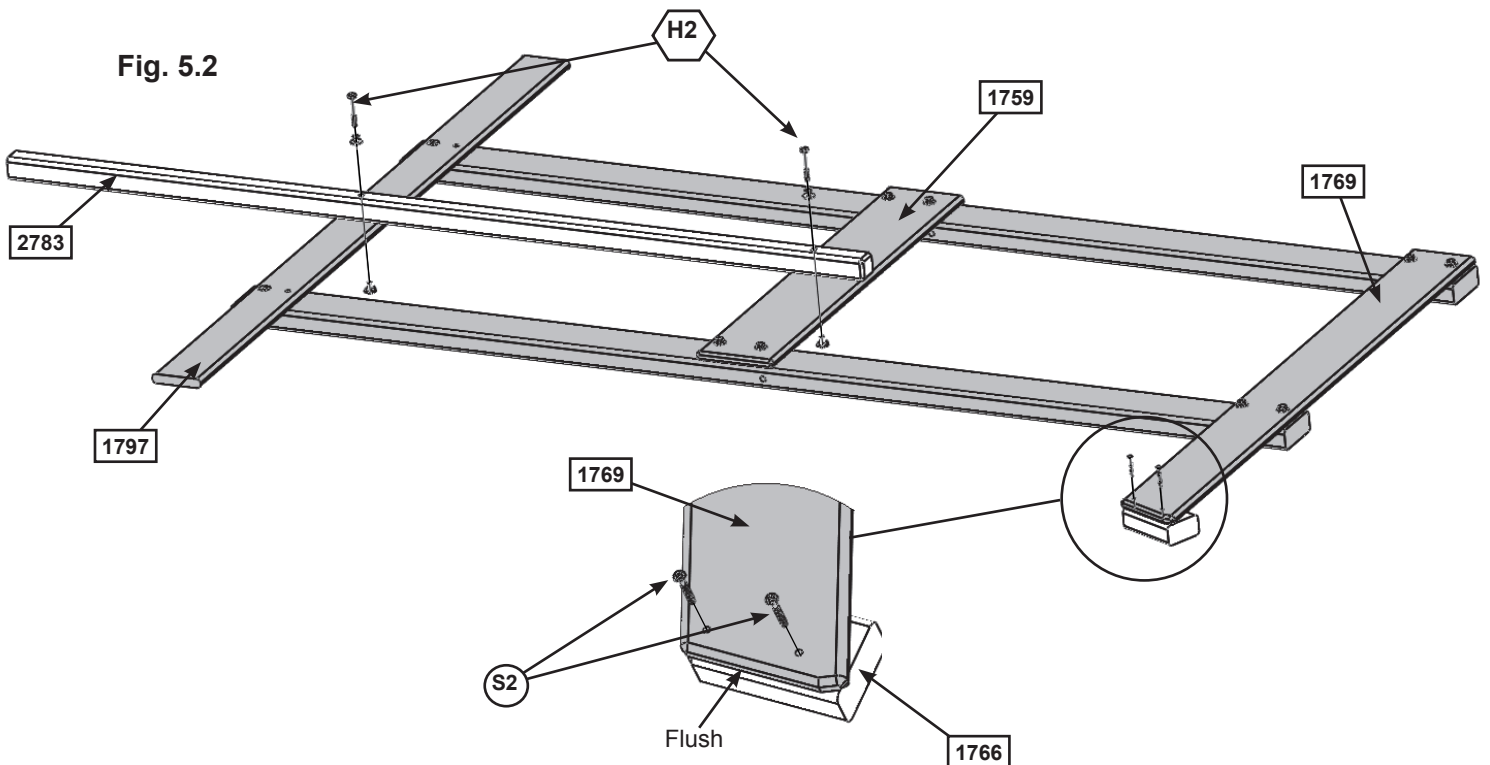

Wood Parts		Hardware	
2 x	1771 Post 2 x 4 x 74"	12 x	H2 1/4 x 2" Hex Bolt (1/4" lock washer, 1/4" flat washer, 1/4" t-nut)
1 x	1769 Ground Side 1 x 5 x 42-1/4"	4 x	S2 #8 x 1-1/2" Wood Screw
1 x	1759 SW Floor 1 x 6 x 26-7/8"		
1 x	1766 Corner Block 2 x 3 x 4-1/2"		
1 x	1797 Side Top 1 x 4 x 51-1/2"		
	1 x 2783 Tarp Upright 2 x 2 x 60"		



Step 6: Front Frame Assembly

A: Attach (1764) Floor Front to (1771) Posts with 2 (H6) 1/4 x 4-3/4" Bolt (with flat washer, lock washer and t-nut). Hex Bolts to be installed from the inside of the assembly. (fig. 6.2)

B: Attach (1752) Top Front to (1771) Posts with 4 (S7) 12 x 2" Pan Screws (with 3/16" flat washer). (1752) Top Front should be flush to the top of each (1771) Post. (fig. 6.1 & 6.2)

Fig. 6.2

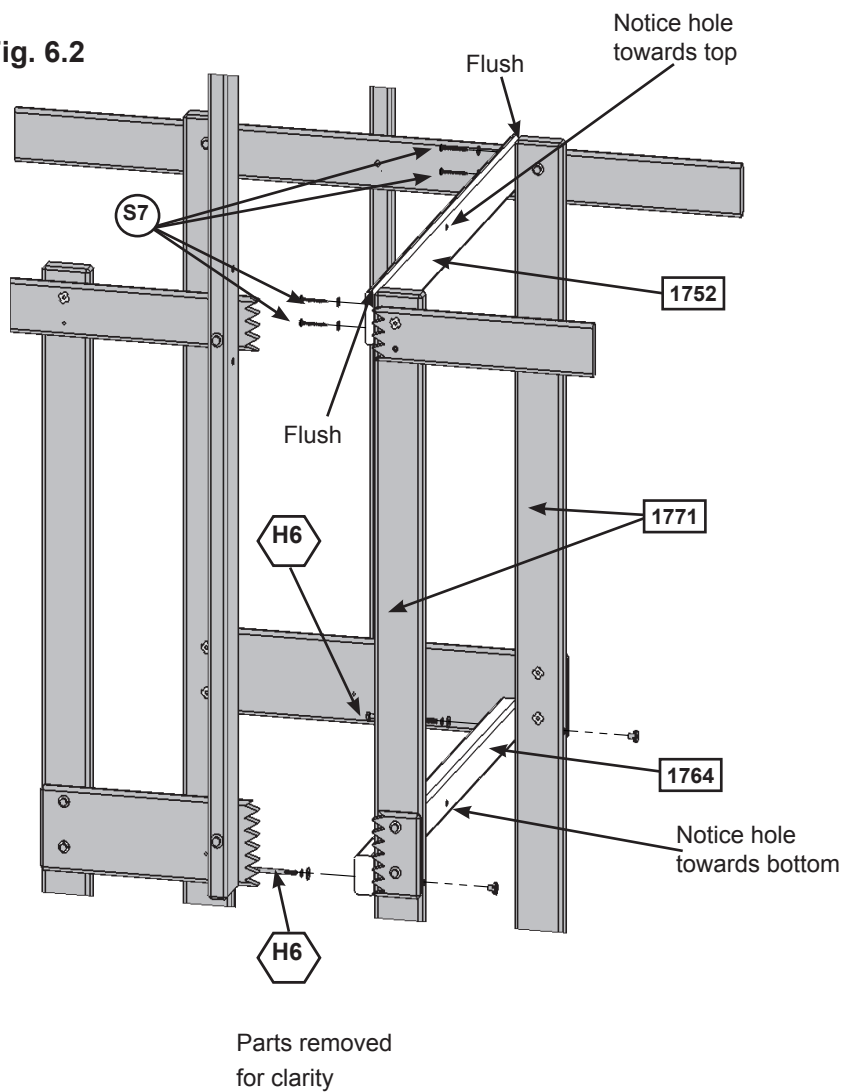
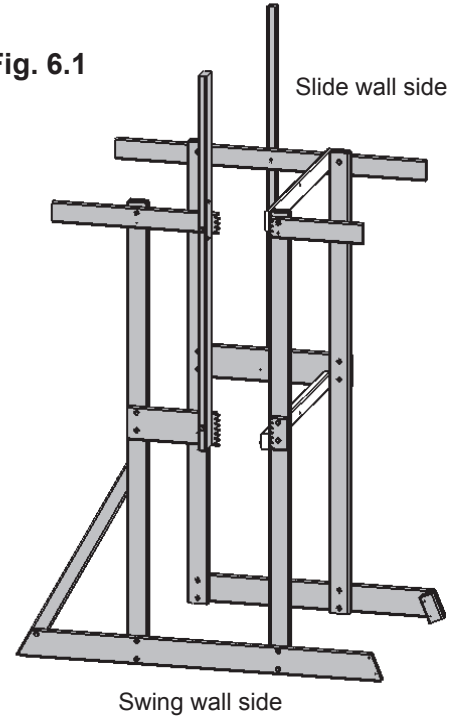

Fig. 6.1



Wood Parts

- 1 x 1764 Floor Front 2 x 3 x 38-1/2"
- 1 x 1752 Top Front 1 x 4 x 38-1/2"

Hardware

- 2 x H6 1/4 x 4-3/4" Hex Bolt (1/4" lock washer, 1/4" flat washer, 1/4" t-nut)
- 4 x S7 #12 x 2" Pan Screw (with 3/16" flat washer)

Step 7: Rock Rail Assembly

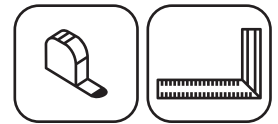

A: Attach (1766) Corner Block 1/2" from bottom of (1765) Rock Rail with 2 (S3) 8 x 2-1/2" Wood Screws as shown in fig. 7.1.

B: Place (1765) Rock Rail with Corner Block against (1764) Floor Front so the top of the angled edge is 3/8" above (1764) Floor Front. Do not attach to (1764) Floor Front until Step 20. (fig. 7.2 & 7.3)

C: Make sure the assembly is square then attach (1770) SW Ground to (1766) Corner Block with 2 (S2) #8 x 1-1/2" Wood Screws as shown in fig. 7.2 & 7.4.

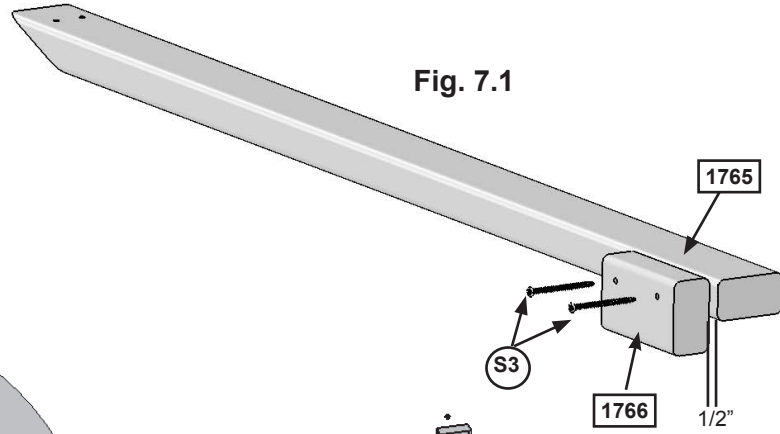

Fig. 7.1

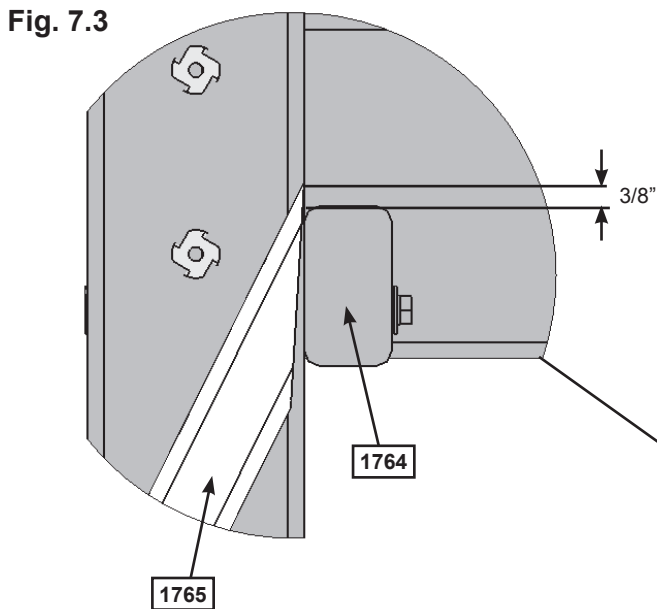

Fig. 7.3

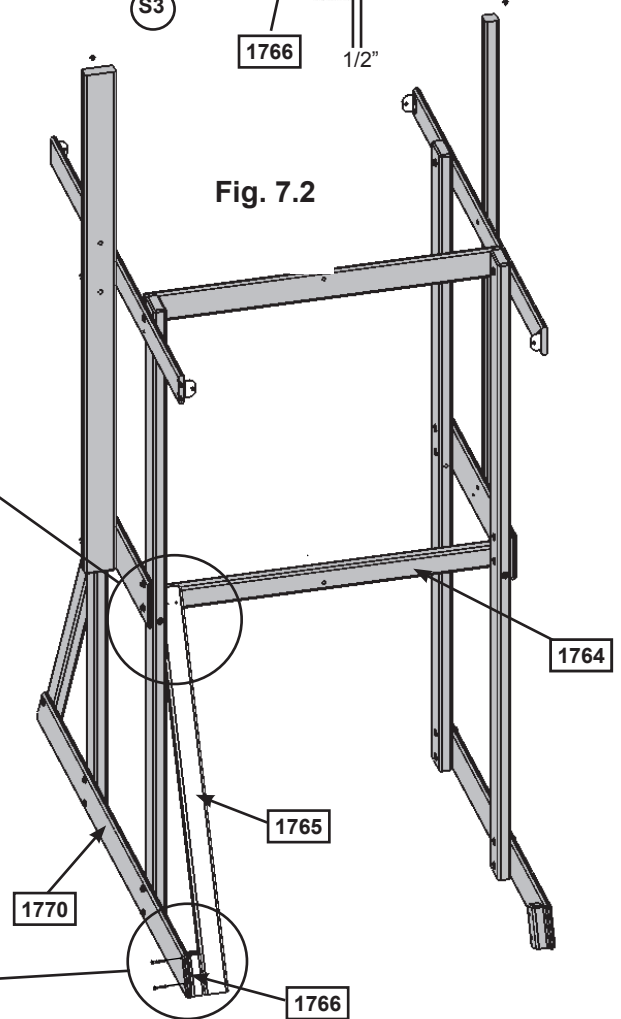

Fig. 7.2

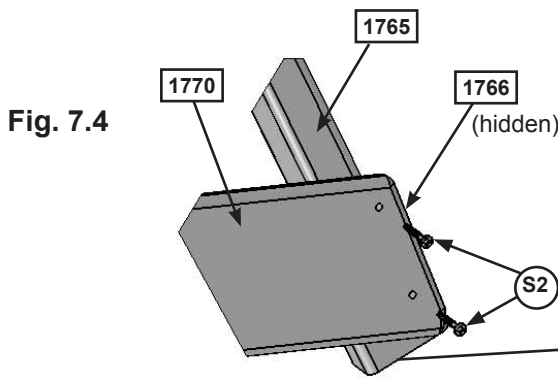

Fig. 7.4

Wood Parts

- 1 x 1766 Corner Block 2 x 3 x 4-1/2"
- 1 x 1765 Rock Rail 2 x 3 x 42-3/4"

Hardware

- 2 x S3 #8 x 2-1/2" Wood Screw
- 2 x S2 #8 x 1-1/2" Wood Screw

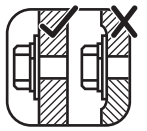

Step 8: Attach Centre Divider

A: Attach (1751) Centre Divider to (1752) Top Front with 1 (H2) 1/4 x 2" Bolt (with flat washer, lock washer and t-nut) from outside of the assembly and to (1764) Floor Front with 1 (H11) 1/4 x 2-3/4" Bolt (with flat washer, lock washer and t-nut) from inside the assembly. (fig. 8.1 and 8.2)

Fig. 8.1

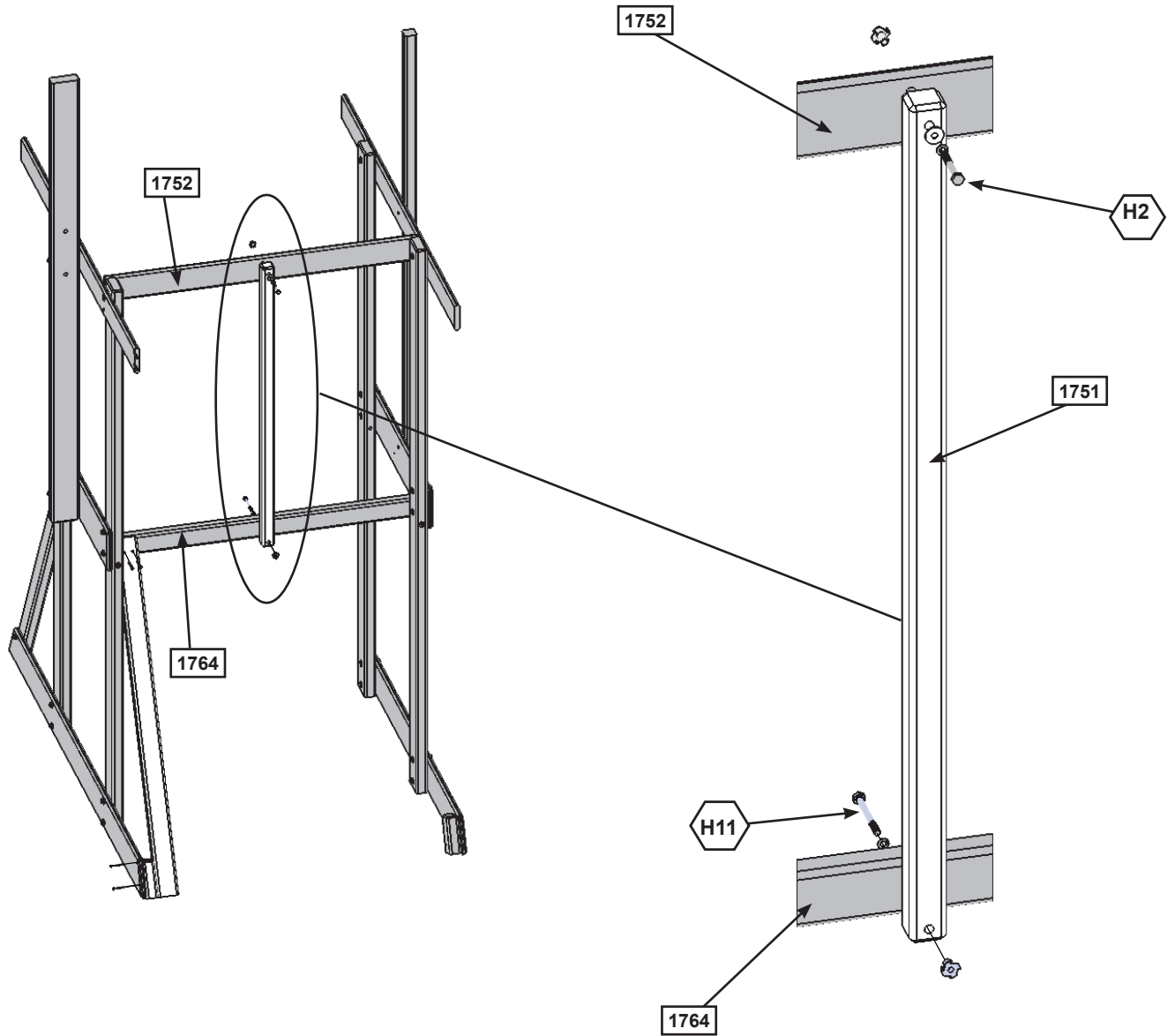

Wood Parts

1 x 1751 Centre Divider 2 x 2 x 38"

Hardware

- 1 x H2 1/4 x 2" Hex Bolt (1/4" lock washer, 1/4" flat washer, 1/4" t-nut)
- 1 x H11 1/4 x 2-3/4" Hex Bolt (1/4" lock washer, 1/4" flat washer, 1/4" t-nut)



Step 9: Attach Gusset

A: Make sure assembly is square and then place 1 (0312) Gusset tight to the under side of (1764) Floor Front and to (1771) Post from the inside of the assembly. Make sure the gusset is flush to the outside of the post and attach with 2 (S4) #8 x 3" Wood Screws per side. (fig. 9.1, 9.2 & 9.3)

Fig. 9.1

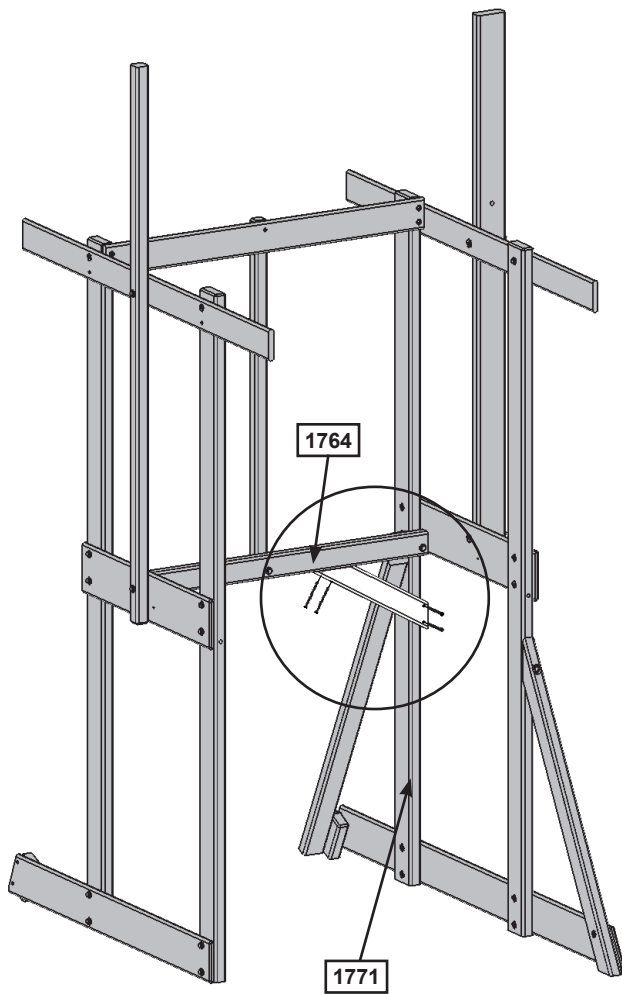

Fig. 9.2

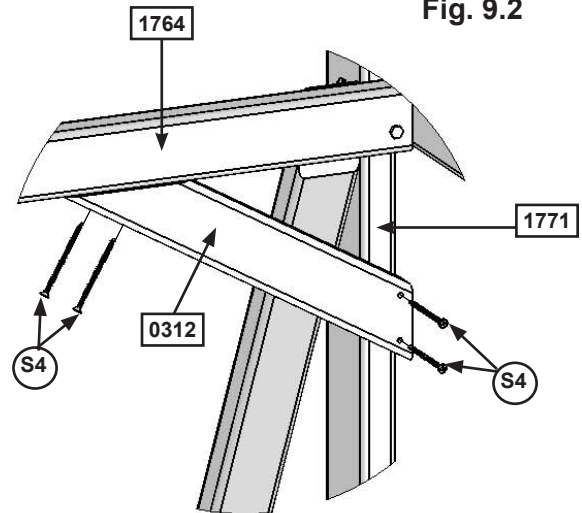
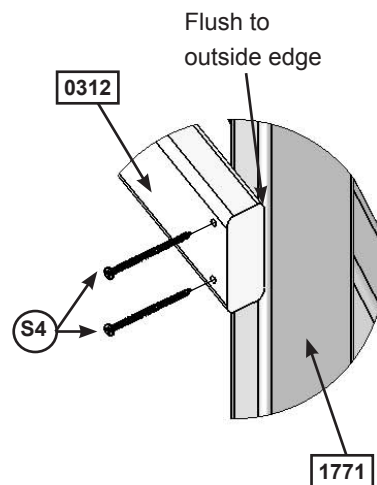

Fig. 9.3



Wood Parts

1 x 0312 Gusset 2 x 3 x 16"

Hardware

4 x S4 #8 x 3" Wood Screw



Step 10: Attach Lower Front

A: Attach (1767) Lower Front flush to the top of (1766) Corner Block at (1769) Ground Side with 2 (S15) #8 x 1-3/4" Screws. (fig. 10.1 & 10.2)

B: Make sure (1767) Lower Front is level and then attach to (1765) Rock Rail with 2 (S15) #8 x 1-3/4" Screws. (fig. 10.1)

Fig. 10.1

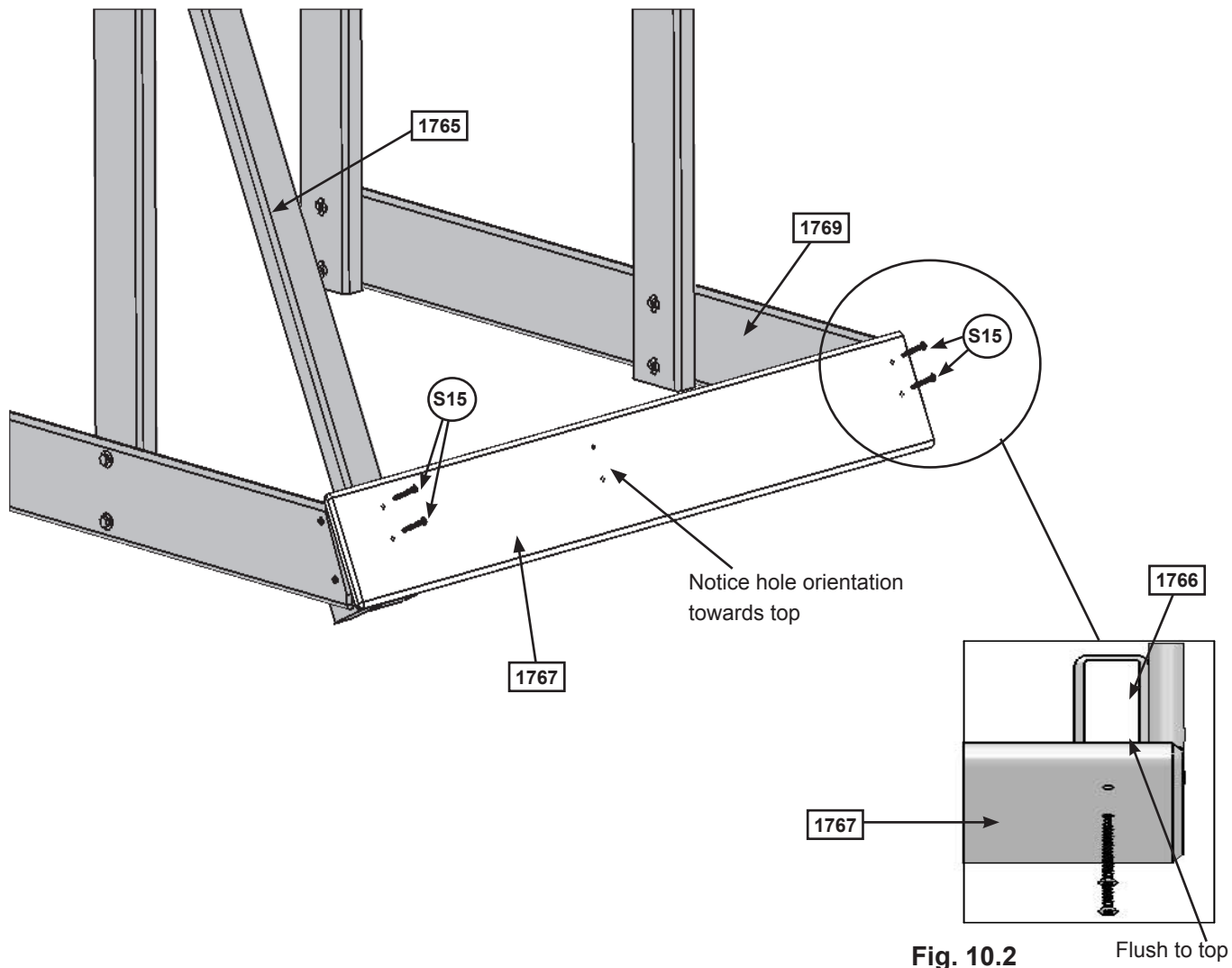

Wood Parts

1 x 1767 Lower Front 1 x 6 x 39-3/4"

Hardware

4 x S15 #8 x 1-3/4" Wood Screw

Step 11: Floor Back Assembly

A: Attach (1762) Floor Back to (1761) Side Joist with 2 (H3) 1/4 x 2-1/2" Bolts (with flat washer, lock washer and t-nut) and 2 (S7) 12 x 2" Pan Screws (with flat washers) as shown in fig. 11.1. Bolts to be installed on (1761) Side Joist side and screws installed from (1762) Floor Back side.

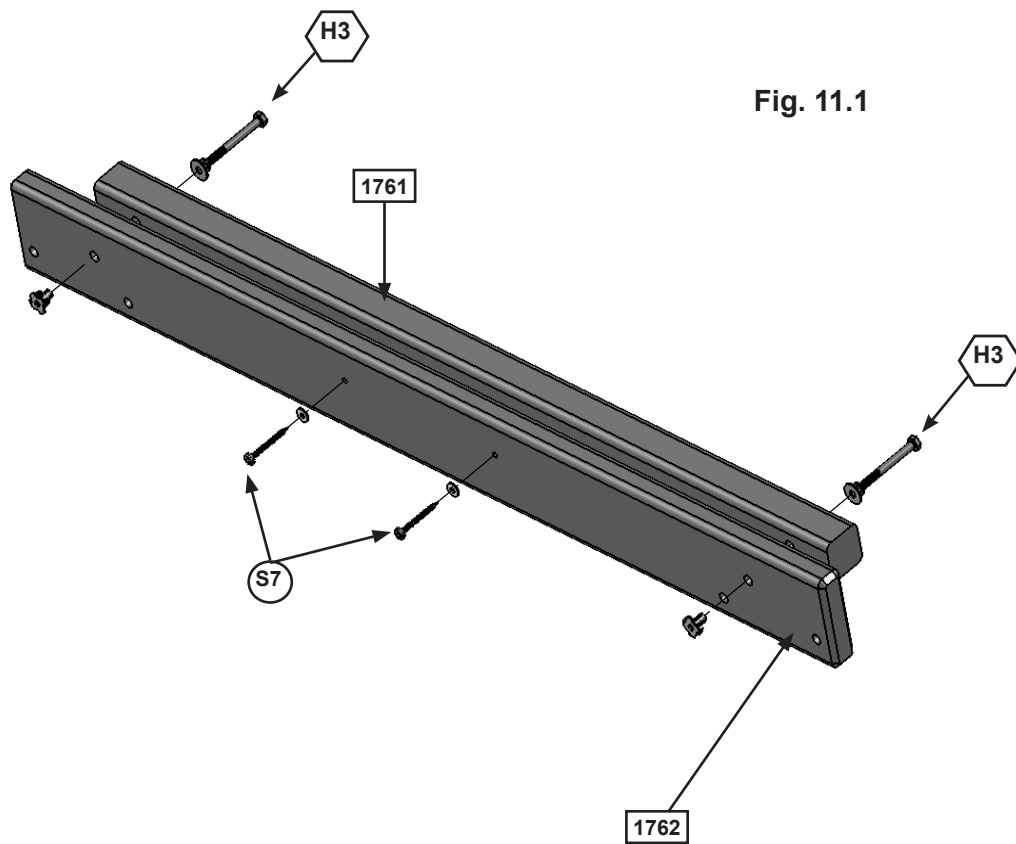

Wood Parts

- 1 x **1761** Side Joist 2 x 2 x 34-3/4"
- 1 x **1762** Floor Back 5/4 x 4 x 38-5/8"

Hardware

- 2 x **S7** #12 x 2 Pan Screw (with 3/16" flat washer)
- 2 x **H3** 1/4 x 2-1/2" Hex Bolt
(1/4" lock washer, 1/4" flat washer, 1/4" t-nut)



Step 12: Floor Back Assembly

Pre-drill all pilot holes using a 1/8" drill bit before installing the lag screws.

A: On the back side of the assembly attach (1768) Lower Back flush to the bottom and outside edge of (1771) Posts with 2 (LS3) 1/4 x 3" Lag Screws (with flat washer) in the top, pre-drilled holes and 2 (S7) 12 x 2" Pan Screws (with 3/16" flat washer) in the bottom holes as shown in fig. 12.1 & 12.3.

B: Attach Floor Back Assembly from Step 11 to both (1771) Posts with 2 (H5) 1/4 x 4-1/2" Hex Bolts (with lock washer, flat washer and t-nut) through (1762) Floor Back. Notice the hole orientation towards bottom of board. (fig. 12.1 & 12.2)

Fig. 12.1

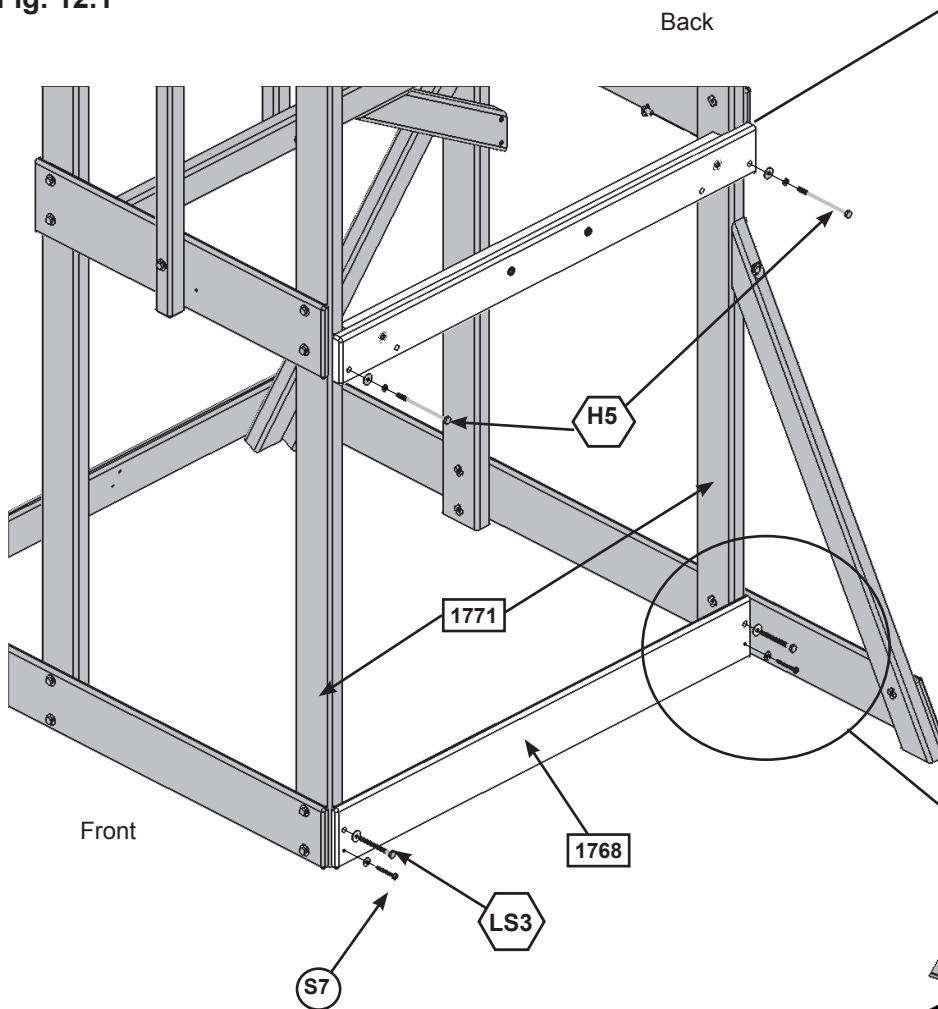

Fig. 12.2

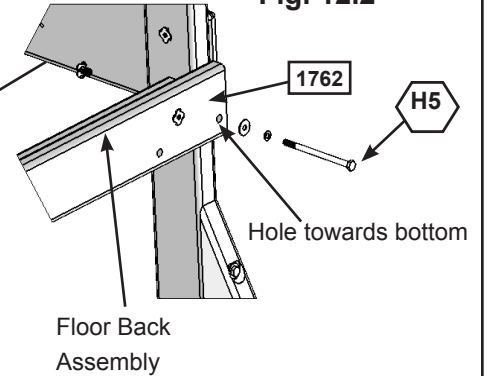
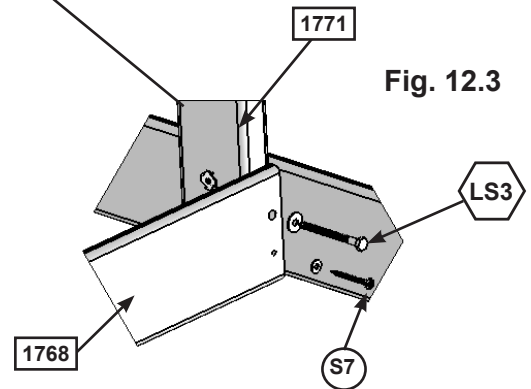

Fig. 12.3



Wood Parts

- 1 x Floor Back Assembly (from Step 11)
- 1 x 1768 Lower Back 1 x 5 x 38-1/2"

Hardware

- 2 x S7 #12 x 2" Pan Screw (with 3/16" flat washer)
- 2 x LS3 1/4 x 3" Lag Screw (1/4" flat washer)
- 2 x H5 1/4 x 4-1/2" Hex Bolt (1/4" lock washer, 1/4" flat washer, 1/4" t-nut)

Step 12: Floor Back Assembly cont.

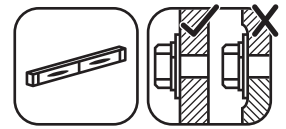

C: Attach 2 (0359) Front Dividers to (1762) Floor Back with 1 (H1) 1/4 x 1-1/2" Hex Bolt (with lock washer, flat washer and t-nut) per board. **Be sure to keep bolts loose.** (fig. 12.4 & 12.6)

D: Attach each (0359) Front Divider to (1758) Top Back using 1 (PB2) 1/4 x 1-1/4" Pan Bolt (with lock washer, flat washer and t-nut) per board. **Be sure to keep bolts loose.** (fig. 12.4 & 12.5)

E: Level and attach (1758) Top Back to both (1771) Posts using 4 (S7) #12 x 2" Pan Screws (with 3/16" flat washers). (fig. 12.7)

Fig. 12.4

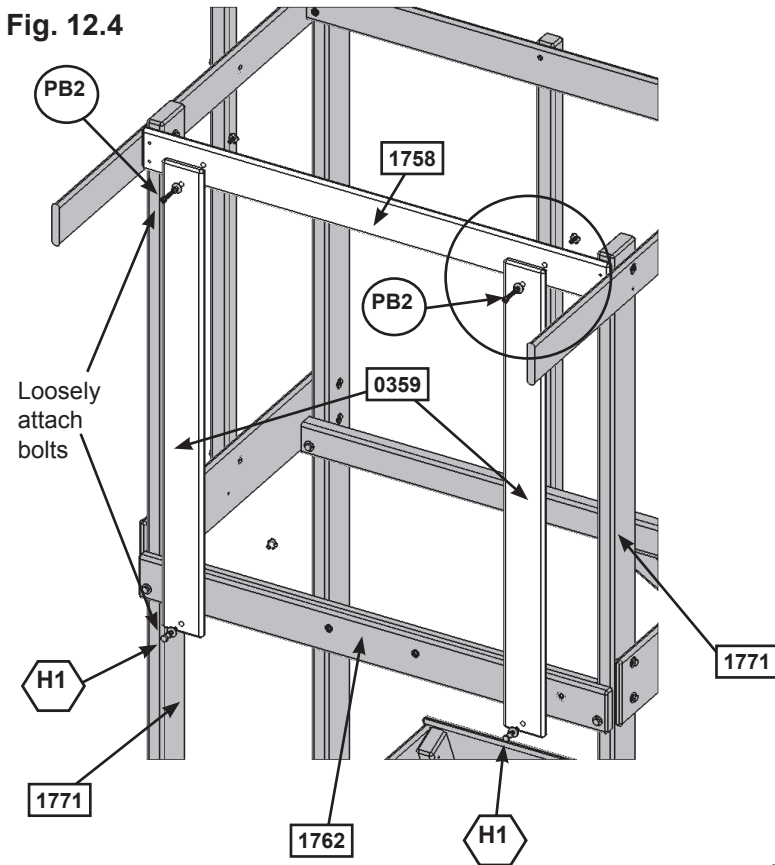

Fig. 12.5

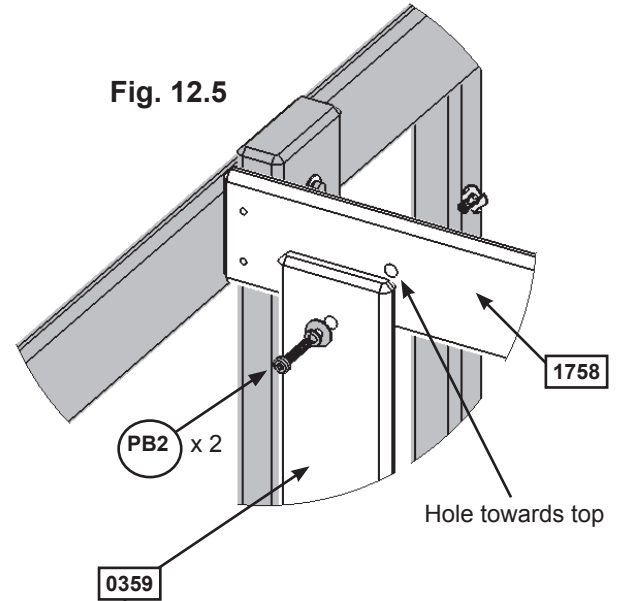

Fig. 12.6

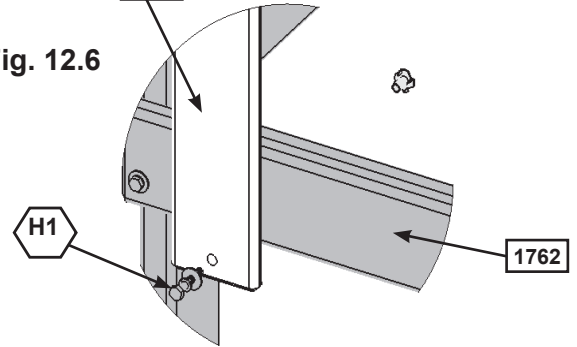
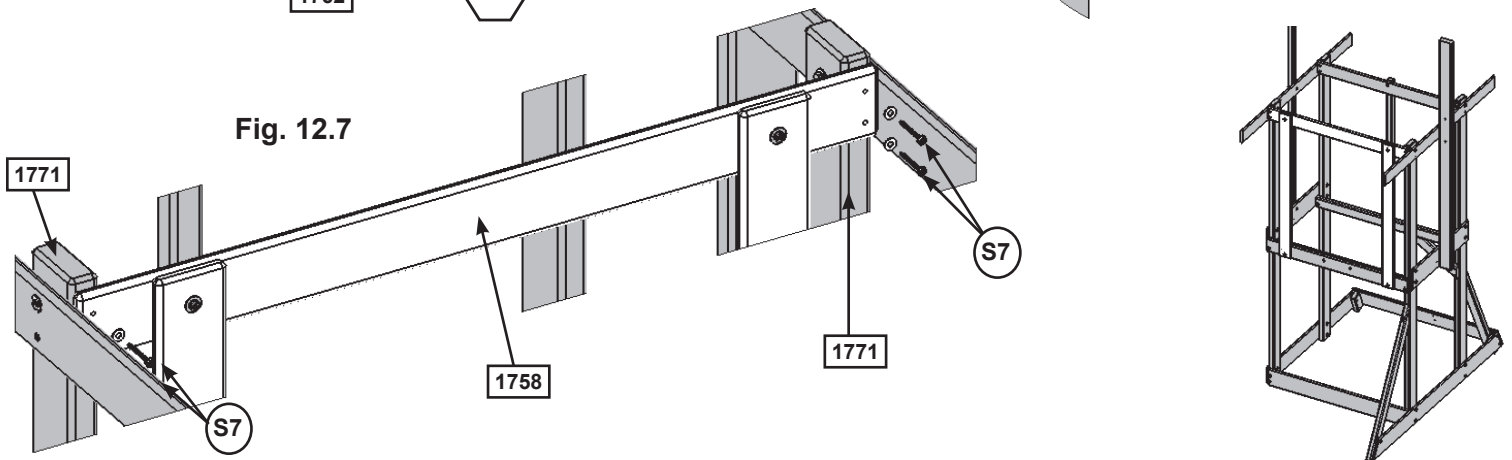

Fig. 12.7



Wood Parts

- 1 x 1758 Top Back 1 x 4 x 38-1/2"
- 2 x 0359 Front Divider 1 x 4 x 38"

Hardware

- 4 x S7 #12 x 2" Pan Screw (with 3/16" flat washer)
- 2 x H1 1/4 x 1-1/2" Hex Bolt (1/4" lock washer, 1/4" flat washer, 1/4" t-nut)
- 2 x PB2 1/4 x 1-1/4" Pan Bolt (1/4" lock washer, 1/4" flat washer, 1/4" t-nut)



Step 13: Chalk Wall Assembly

A: Place the Chalk Wall Tarp in between each (0359) Front Divider and (1758) Top Back. Make sure tarp is smooth and tight and then attach to (1758) Top Back with 3 (S5) #8 x 1/2" Pan Screws (with #8 flat washer). Tighten the bolts in both (0359) Front Dividers. (fig. 13.1)

B: Recheck that tarp is smooth and tight and then measure 4" up from the bottom of the tarp on each side and attach Chalk Wall Tarp to both (0359) Front Dividers from the inside of the assembly with 1 (S5) #8 x 1/2" Pan Screws (with #8 flat washer) per board. Evenly space and attach with 2 more screws per side. (fig. 13.2)

C: 3" above (1762) Floor Back attach (1754) Lower Back Wall to each (0359) Front Divider with 4 (S1) #8 x 1-1/8" Wood Screws. (fig. 13.3)

D: Attach Chalk Wall Tarp to (1754) Lower Back Wall with 3 (S5) #8 x 1/2" Pan Screws (with #8 flat washer). (fig. 13.4)

Fig. 13.2

Fig. 13.1

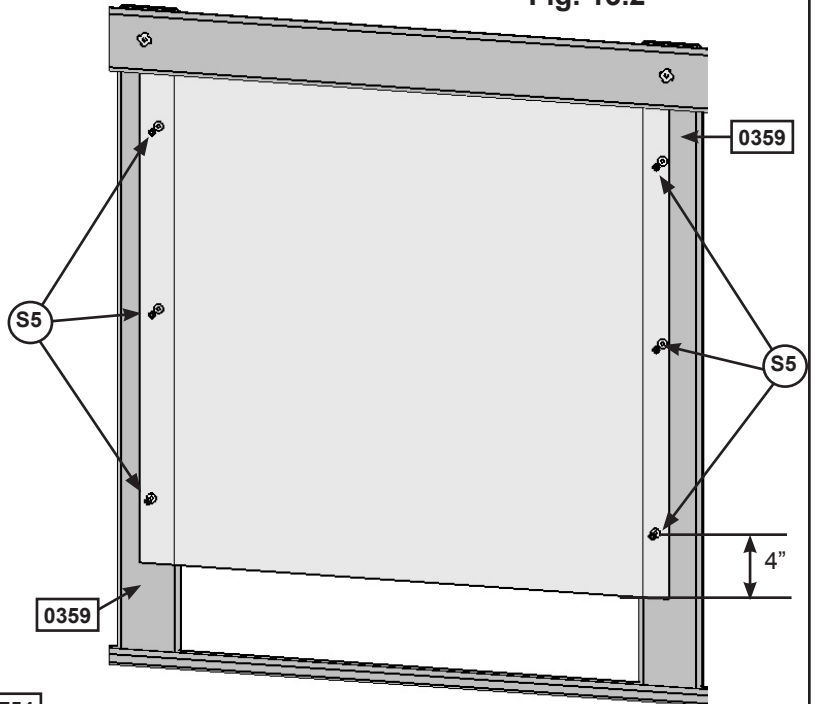
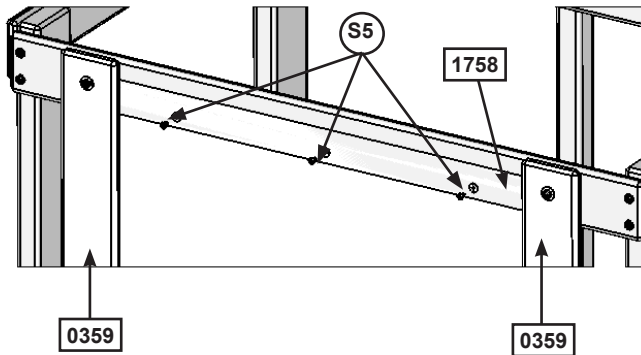

Fig. 13.4

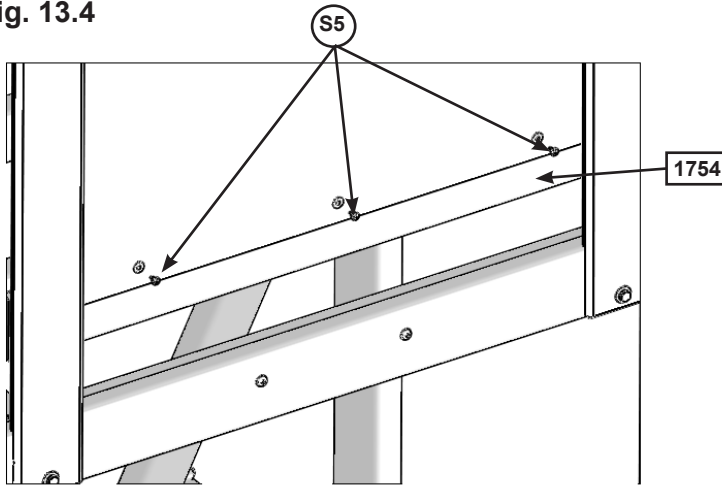
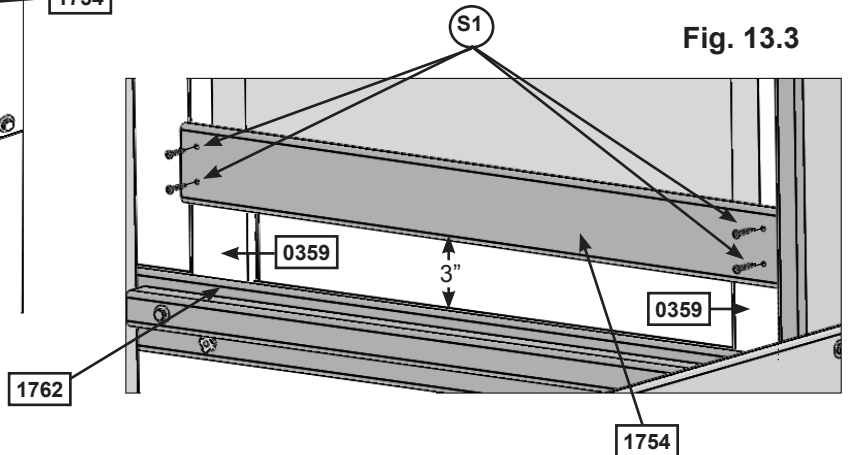

Fig. 13.3



Wood Parts

1 x 1754 Lower Back Wall 1 x 4 x 31-1/2"

Hardware

12 x (S5) #8 x 1/2 Pan Screw (with #8 flat washer)

4 x (S1) #8 x 1-1/8 Wood Screw

Other Parts

1 x Chalk Wall Tarp

Step 14: Floor Frame Assembly



A: From inside of the assembly, measure 3-1/8" down from the top of both (1759) SW Floors then attach (1763) Floor Joist to each board with 1 (S4) #8 x 3" Wood Screws per end. Make sure the (1763) Floor Joist is installed with the side measuring 1-3/8" facing up. (fig. 14.1, 14.2 & 14.3)

Fig. 14.1

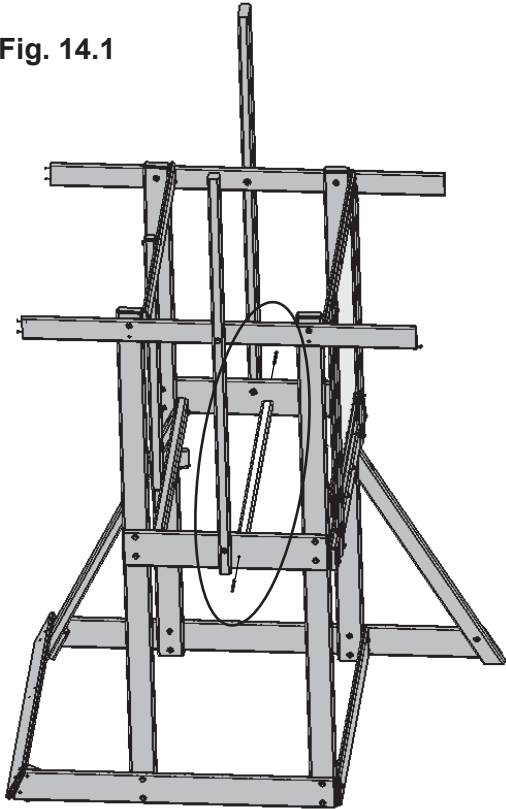

Fig. 14.2

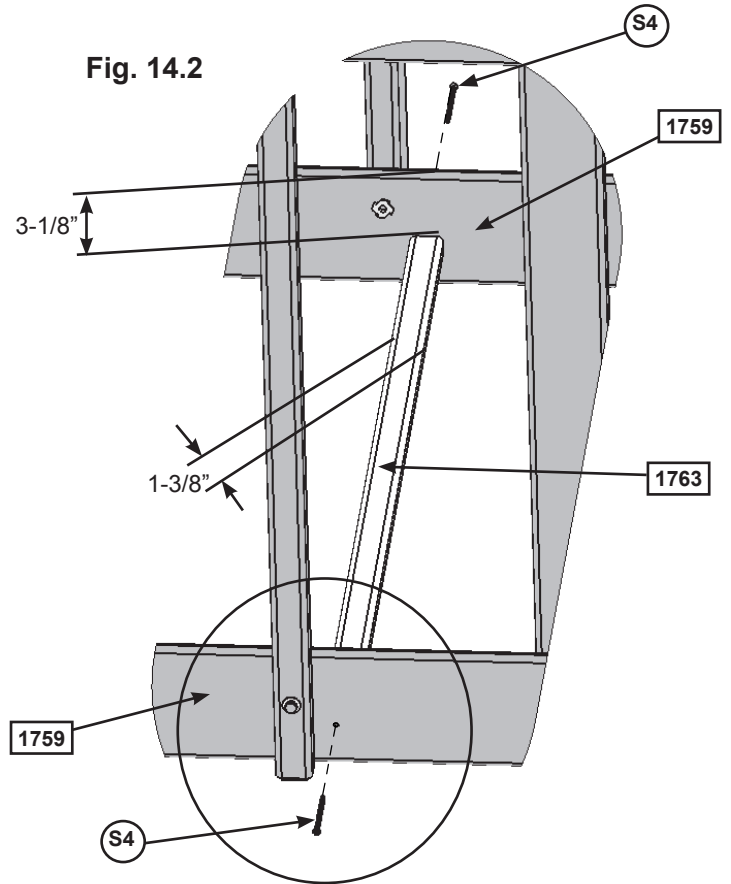
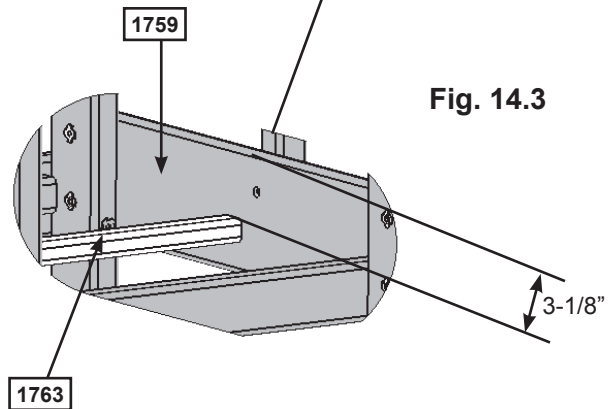

Fig. 14.3



Wood Parts

1 x **1763** Floor Joist 5/4 x 2 x 38-1/2"

Hardware

2 x **(S4)** #8 x 3" Wood Screw

Step 15: Attach Floor Boards

A: Install 1 (1774) CE Gap Board to each end of the assembly attaching to (1761) Side Joist, (1763) Floor Joist and (1764) Front Floor using 5 (S2) #8 x 1-1/2" Wood Screws per board. Make sure boards are tight to each (1759) SW Floor, (1762) Floor Back and each (1771) Post. (fig. 15.1)

B: In between both (1774) CE Gap Boards place 5 (A5) Floor Boards making sure all boards are evenly spaced. Attach to (1761) Side Joist, (1763) Floor Joist and (1764) Front Floor using 5 (S2) #8 x 1-1/2" Wood Screws per board. All boards should be tight to (1762) Floor Back. (fig. 15.2)

C: Tight to (1751) Centre Divider and flush to top of (1775) Floor Board attach (1766) Corner Block to (1764) Floor Front with 2 (S3) #8 x 2-1/2" Wood Screws. (fig. 15.2 & 15.3)

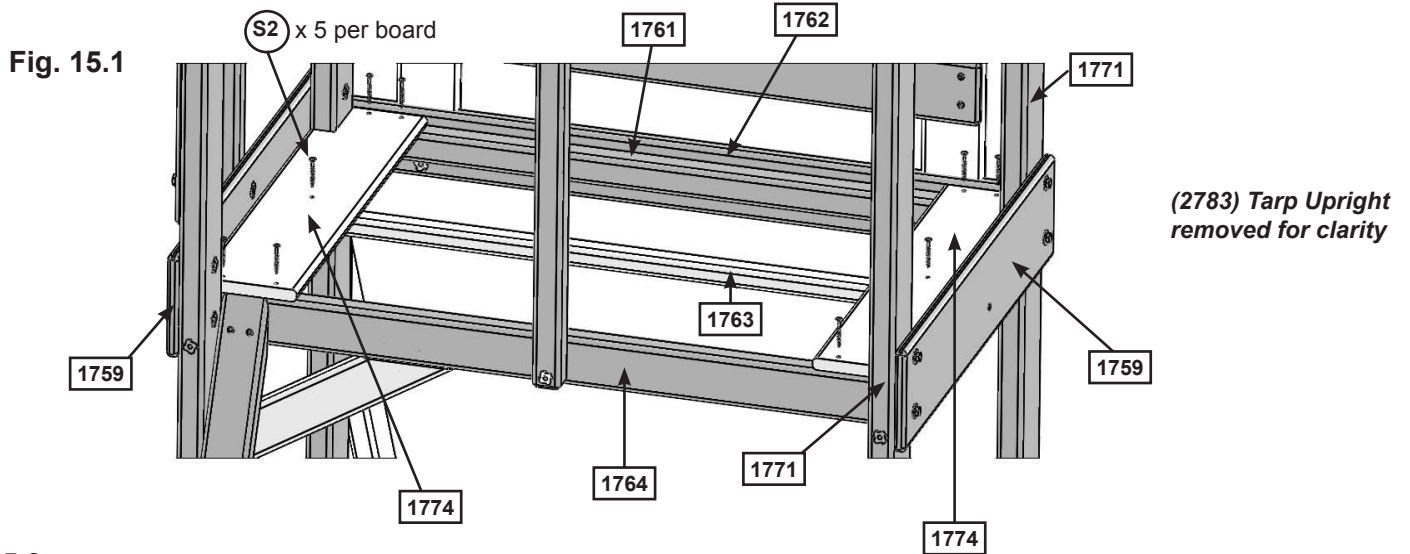

Fig. 15.3

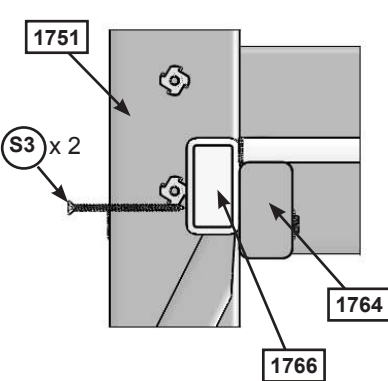
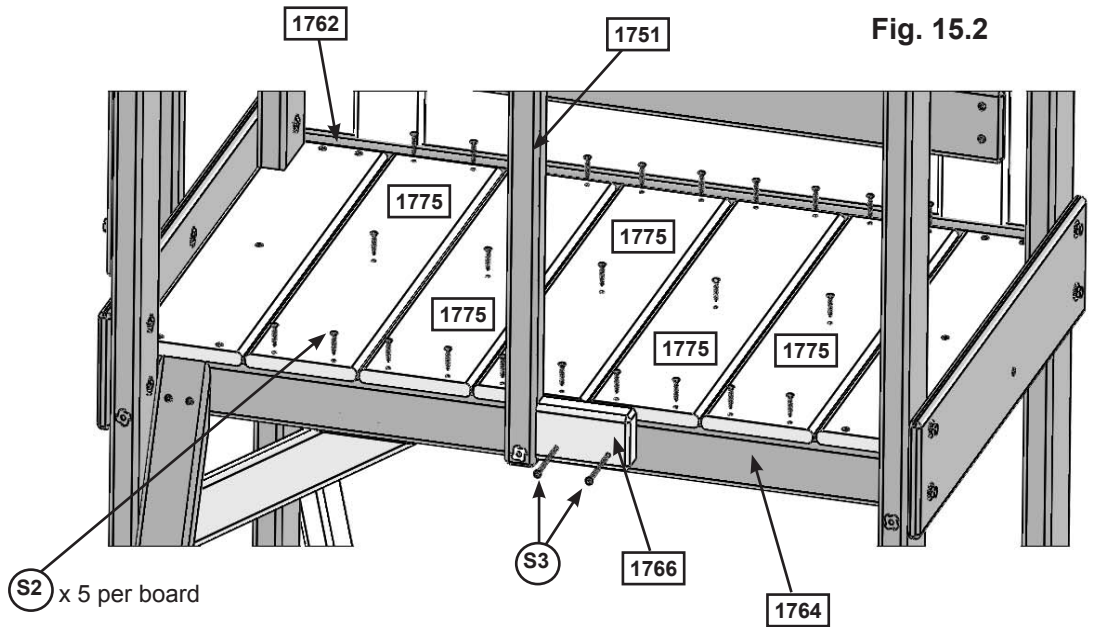

Fig. 15.2



Wood Parts

- 5 x 1775 Floor Board 1 x 6 x 23-1/2"
- 2 x 1774 CE Gap Board 1 x 6 x 23-1/2"
- 1 x 1766 Corner Block 2 x 3 x 4-1/2"

Hardware

- 35 x (S2) #8 x 1-1/2" Wood Screw
- 2 x (S3) #8 x 2-1/2" Wood Screw

Step 16: Attach Ground Stakes

MOVE FORT TO FINAL LOCATION. FINAL LOCATION MUST BE ON LEVEL GROUND

A: Drive 2 (0318) Ground Stakes 10-1/2" into the ground against 2 (1771) Posts and (1770) SW Ground. Attach to (1771) Posts using 2 (S3) #8 x 2-1/2" Wood Screws per ground stake. (fig. 16.1 & 16.2)

⚠WARNING: To prevent tipping and avoid potential injury, stakes must be driven 10-1/2" into ground. Digging or driving stakes can be dangerous if you do not check first for underground wiring, cables or gas lines.

Fig. 16.1

Floor boards were removed for clarity

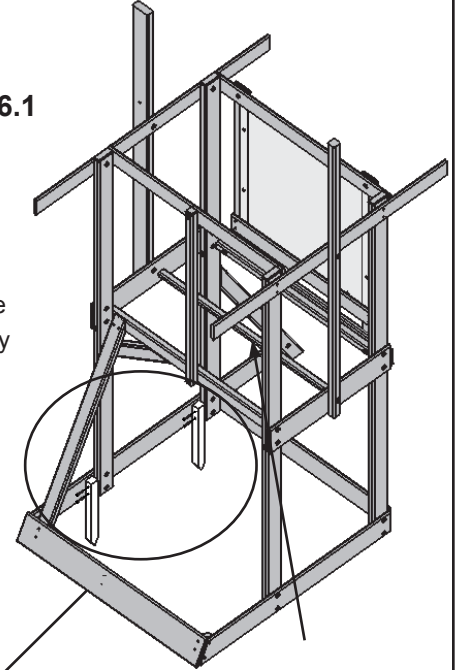
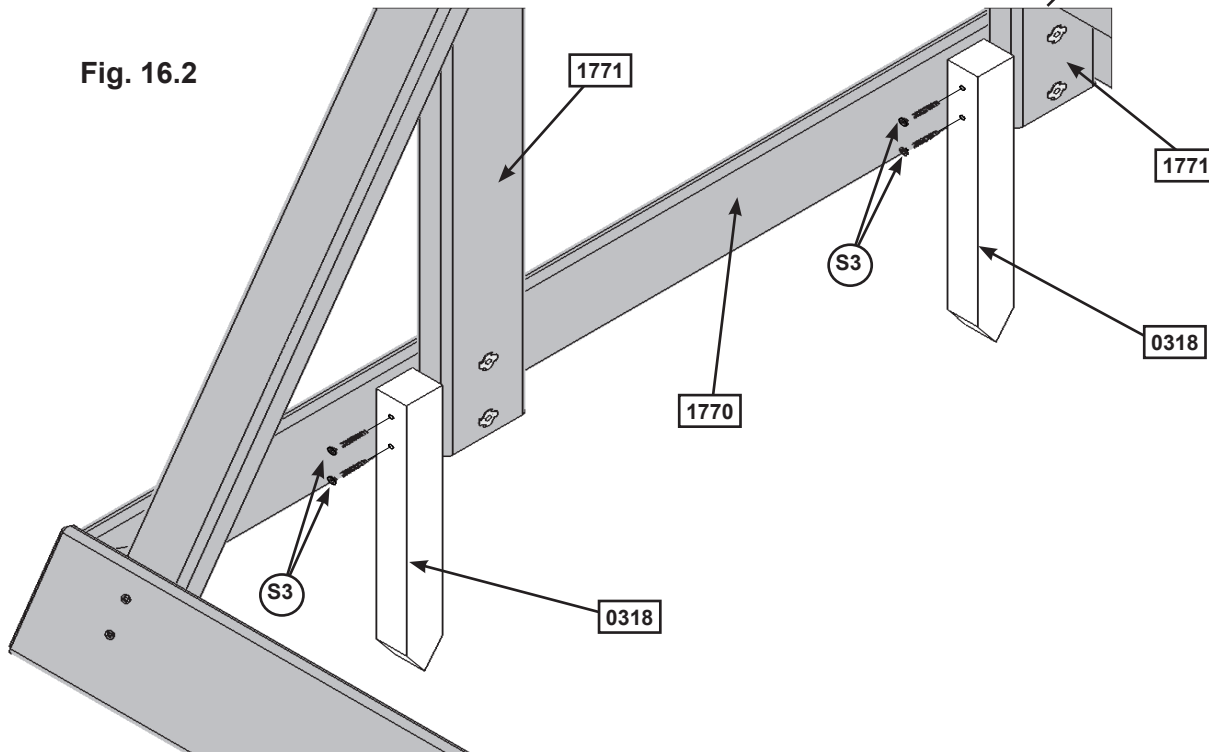

Fig. 16.2



Wood Parts

2 x 0318 Ground Stake 1 1/4 x 1 1/2 x 14"

Hardware

4 x S3 #8 x 2-1/2" Wood Screw



Step 17: Wall Assembly

A: On the Swing Side Wall attach 1 (0304) CE Floor Board on each side of the (2782) SW Mount with 4 (S1) #8 x 1 1/8" Wood Screws per board. Make sure the bottom of the boards are 1" up from the (1774) CE Gap Boards and there is approximately 3" between each (1771) Post and (0304) CE Floor Board, not exceeding 3-1/4". (fig. 17.1 & 17.2)

B: On the opposite wall attach 1 (0304) CE Floor Board on each side of (2783) Tarp Upright with 4 (S1) #8 x 1-1/8" Wood Screws per board. Make sure the bottom of the boards are 1" up from the (1774) CE Gap Board and there is approximately 3" between each board, not exceeding 3-1/4". (fig. 17.3 & 17.4)

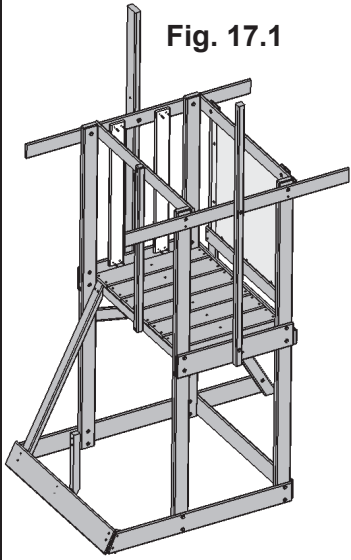

Fig. 17.1

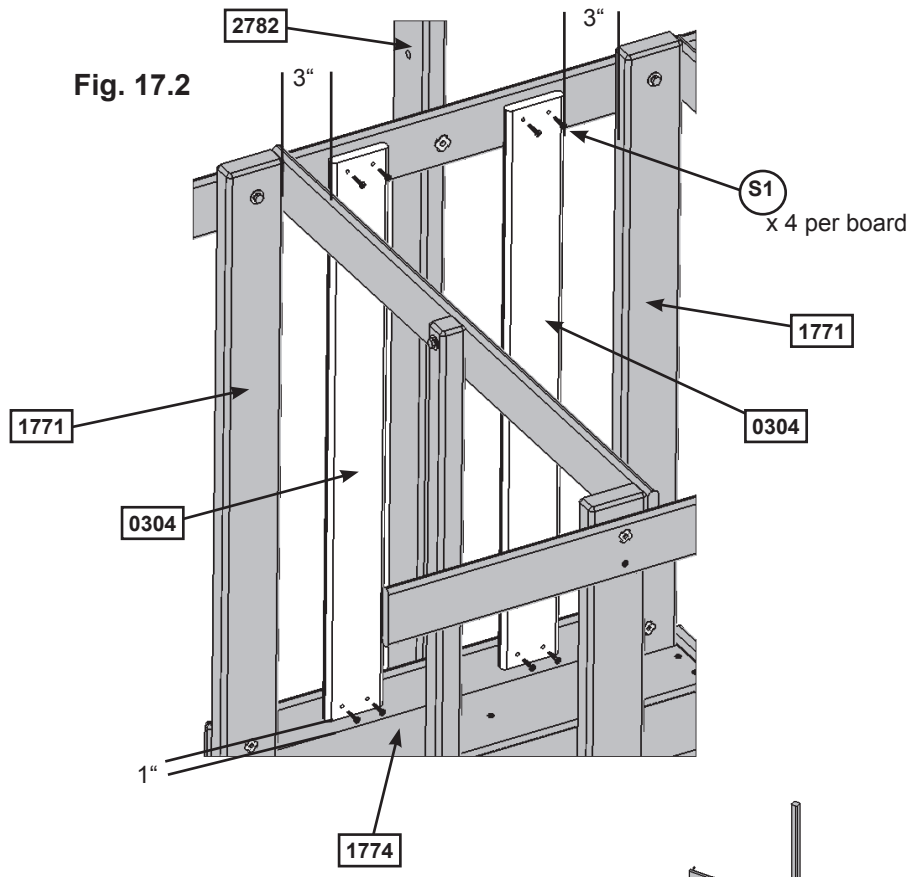

Fig. 17.2

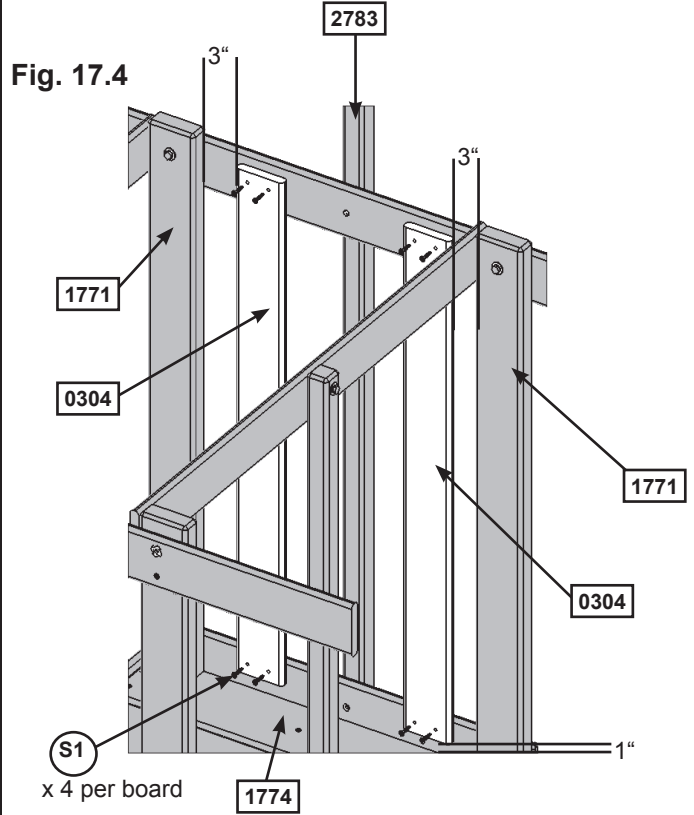

Fig. 17.4

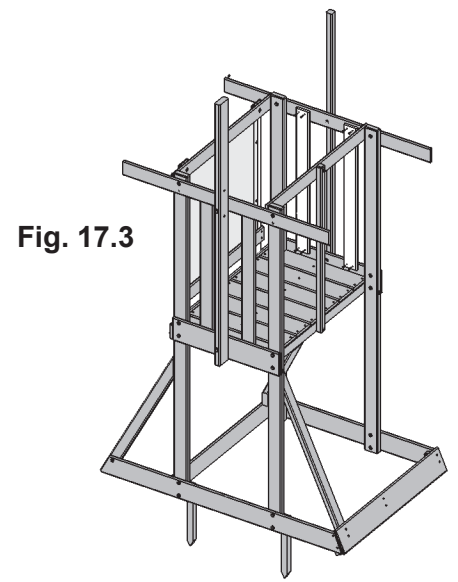

Fig. 17.3

Wood Parts

4 x [0304] CE Floor Board 1 x 4 x 32-1/2"

Hardware

16 x (S1) #8 x 1-1/8" Wood Screw

Step 18: Attach Tarp Frame



A: Attach (1794) Ridge to (2783) Tarp Upright and flush to end of (2782) SW Mount using 3 (S3) #8 x 2-1/2" Wood Screws as shown in fig. 18.1.

B: Pre-drill pilot holes for the screws using a 1/8" drill bit and then attach 1 (1796) Top End to each end of each (1797) Side Top, making sure the pilot holes are centred on the end of (1797) Side Top, with 4 (S2) #8 x 1-1/2" Wood Screws per (1796) Top End. The top of (1796) Top End should be flush to the top of (1797) Side Top. (fig. 18.1)

C: At all 4 corners attach 1 Corner Brace using 3 (S5) #8 x 1/2" Pan Screws per brace as shown in fig.18.1 & 18.2.

Fig. 18.2

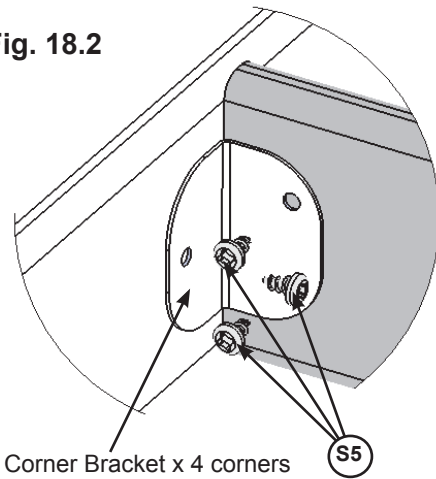
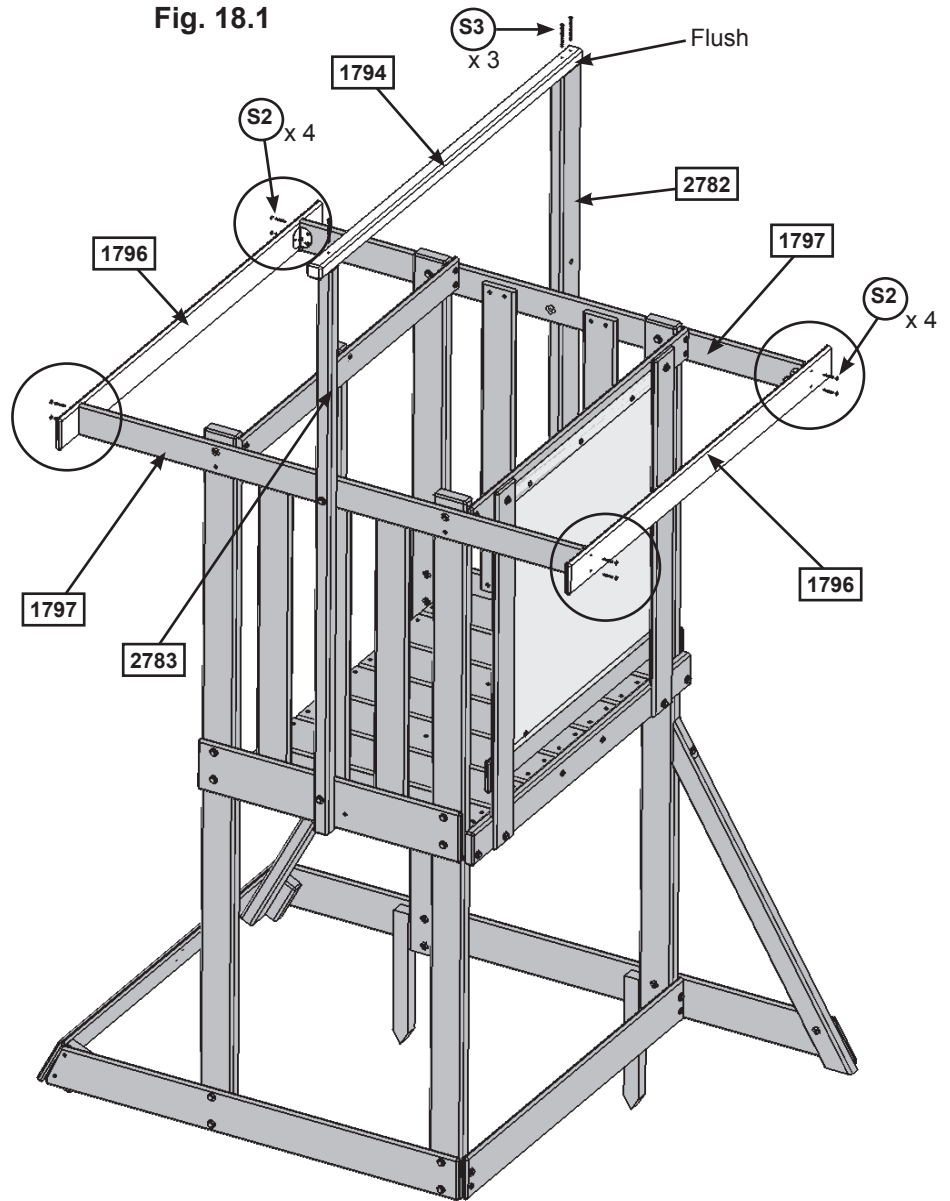

Fig. 18.1



Wood Parts

- 1 x 1794 Ridge 2 x 2 x 46-1/2"
- 2 x 1796 Top End 1 x 4 x 46-1/2"

Hardware

- 3 x S3 #8 x 2-1/2" Wood Screw
- 8 x S2 #8 x 1-1/2" Wood Screw
- 12 x S5 #8 x 1/2" Pan Screw

Other Parts

- 4 x Corner Brace

Step 19: Attach Canopy

A: Place Canopy over (1794) Ridge making sure bottom edges of Canopy are even on both sides of assembly. (fig. 19.1)

B: Secure one side by attaching Canopy to 1 (1796) Top End using 5 (S5) #8 x 1/2" Pan Screws (with #8 flat washer). (fig. 19.1)

C: Make sure the Canopy is smooth and tight and then secure to the remaining (1796) Top End using 5 (S5) #8 x 1/2" Pan Screws (with #8 flat washer). (fig. 19.1)

D: Attach Canopy to each end of (1794) Ridge using 2 (S5) #8 x 1/2" Pan Screws (with #8 flat washer). (fig. 19.1)

Fig. 19.1

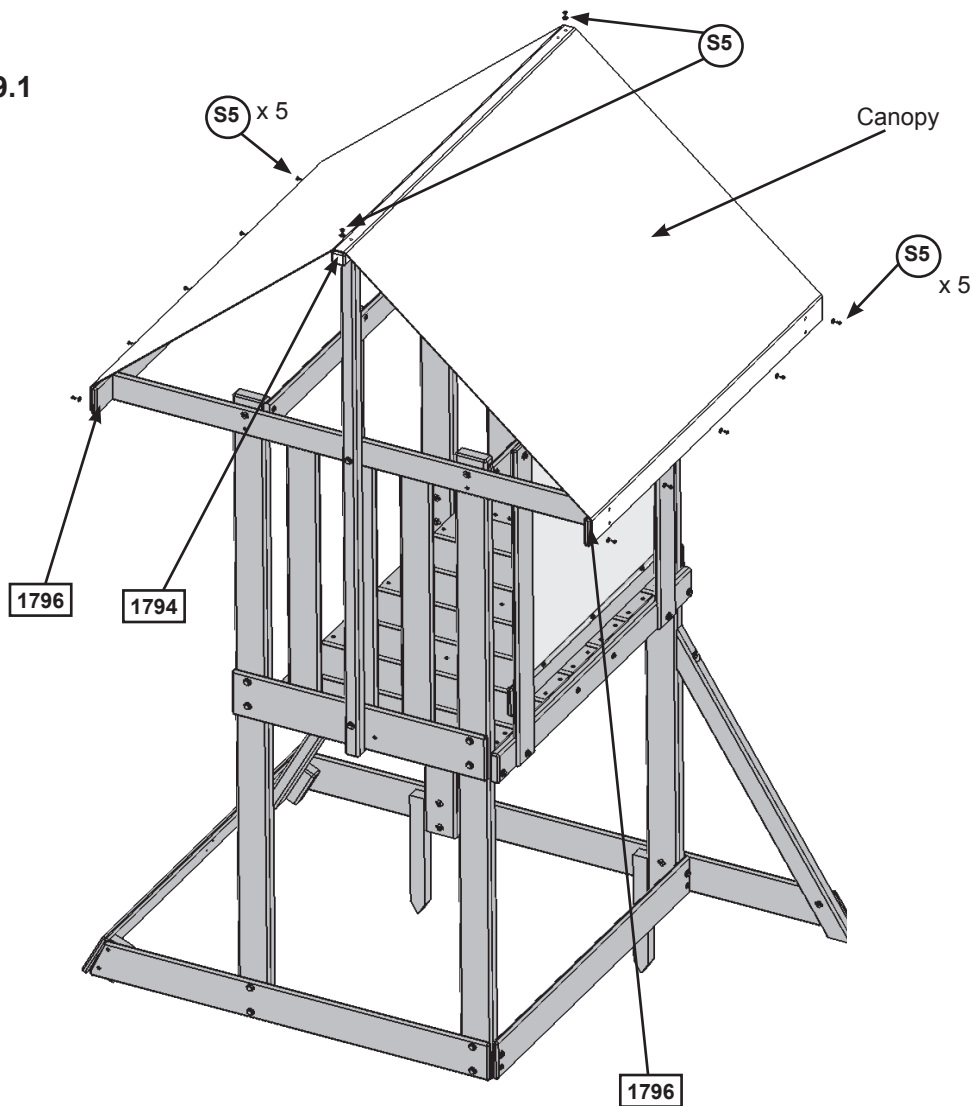

Hardware

12 x (S5) #8 x 1/2" Pan Screw (with #8 flat washer)

Other Parts

1 x Canopy



Step 20: Attach Rock Rail

A: Place 1 (1765) Rock Rail 17" from the already installed (1765) Rock Rail so the top measures 3/8" above (1764) Floor Front then attach both (1765) Rock Rails to (1764) Floor Front with 2 (S15) #8 x 1-3/4" Wood Screws per board and second (1765) Rock Rail to (1767) Lower Front with 2 (S15) #8 x 1-3/4" Wood Screws. (fig. 20.1 & 20.2)

B: Attach (1779) CE Access Board to the top of each (1765) Rock Rail as shown in fig. 20.3. Make sure (1779) CE Access Board is flush to the outside and top edges of each Rock Rail. Attach using 4 (S2) #8 x 1-1/2" Wood Screws. (fig. 20.3)

C: 2-5/16" down from the bottom of (1779) CE Access Board attach 2 (1776) CE Rock Board As and 2 (1777) CE Rock Board Bs in any order so they are staggered to ensure the rock holes do not form a straight line. Make sure the sides are flush to the outside edges of each (1765) Rock Rail. Attach using 4 (S2) #8 x 1-1/2" Wood Screws per board. Make sure the gap between boards are evenly spaced 2-5/16" and do not exceed 2-1/2". (fig. 20.3)

D: Place 1 rock on each (1776) CE Rock Board A and (1777) CE Rock Board B and attach using 1 (PB2) 1/4 x 1-1/4" Pan Bolt (with lock washer, flat washer and barrel nut) and 1 (S10) #8 x 1" Pan Screw per rock. The screw must be in the hole directly under the Pan Bolt, it will stop the rock from spinning. (fig. 20.3 and fig. 20.4)

Fig. 20.1

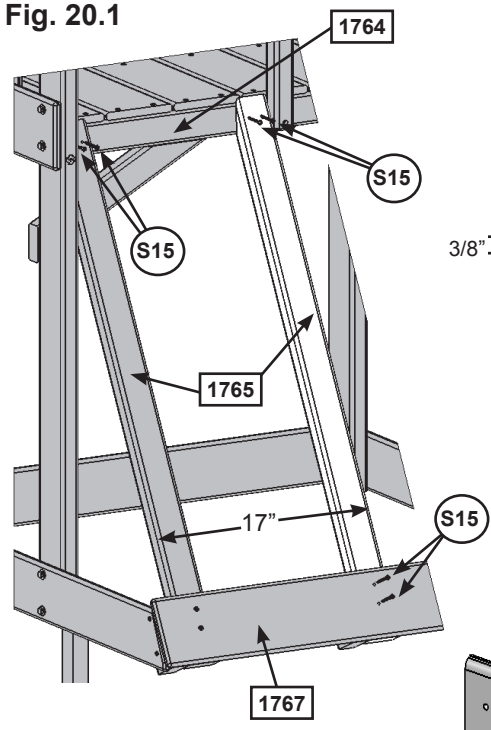

Fig. 20.2

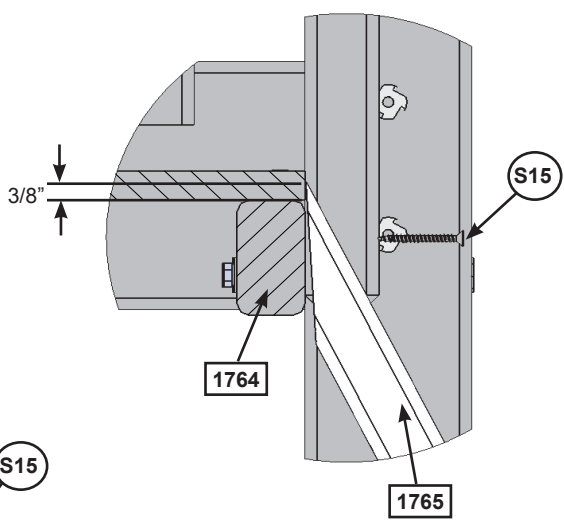

Fig. 20.3

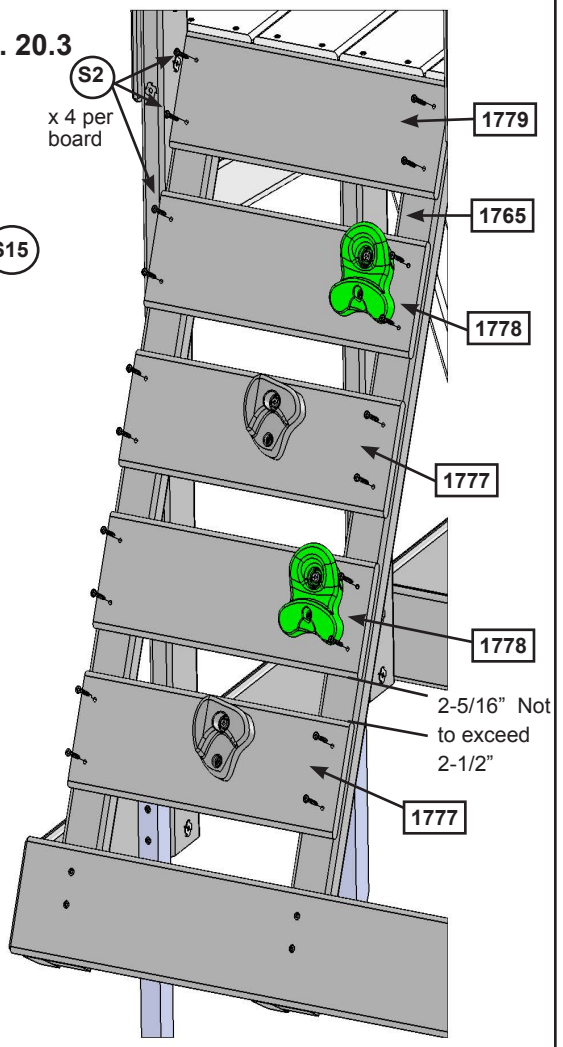
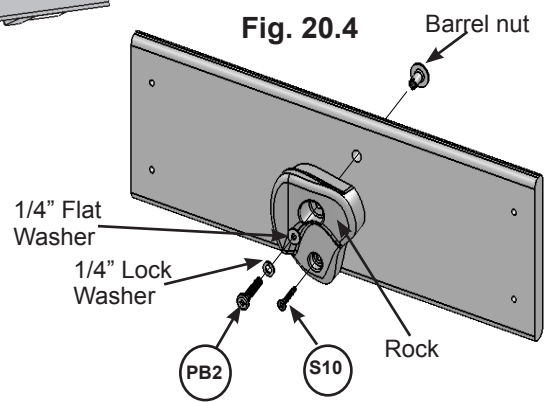

Fig. 20.4



Wood Parts

- 2 x 1778 CE Rock Board A 1 x 6 x 17"
- 2 x 1777 CE Rock Board B 1 x 6 x 17"
- 1 x 1779 CE Access Board 1 x 6 x 17"
- 1 x 1765 Rock Rail 2 x 3 x 42-3/4"

Hardware

- 20 x S2 #8 x 1-1/2" Wood Screw
- 6 x S15 #8 x 1-3/4" Wood Screw
- 4 x S10 #8 x 1" Pan Screw
- 4 x PB2 1/4 x 1-1/4 Pan Bolt (1/4" lock washer, 3/16" flat washer & 1/4" barrel nut)

Other Parts

- 1 x Rock (pkg of 4)



Step 21: Attach Slide

A: Beside Rock Wall, centre slide in opening between (1751) Centre Divider and (1771) Post.

B: Pre-drill 1/8" pilot holes and attach slide to fort through the floor boards and into (1764) Floor Front using 2 (S7) #12 x 2" Pan Screws. (fig. 21.1 & 21.2)

Fig. 21.1

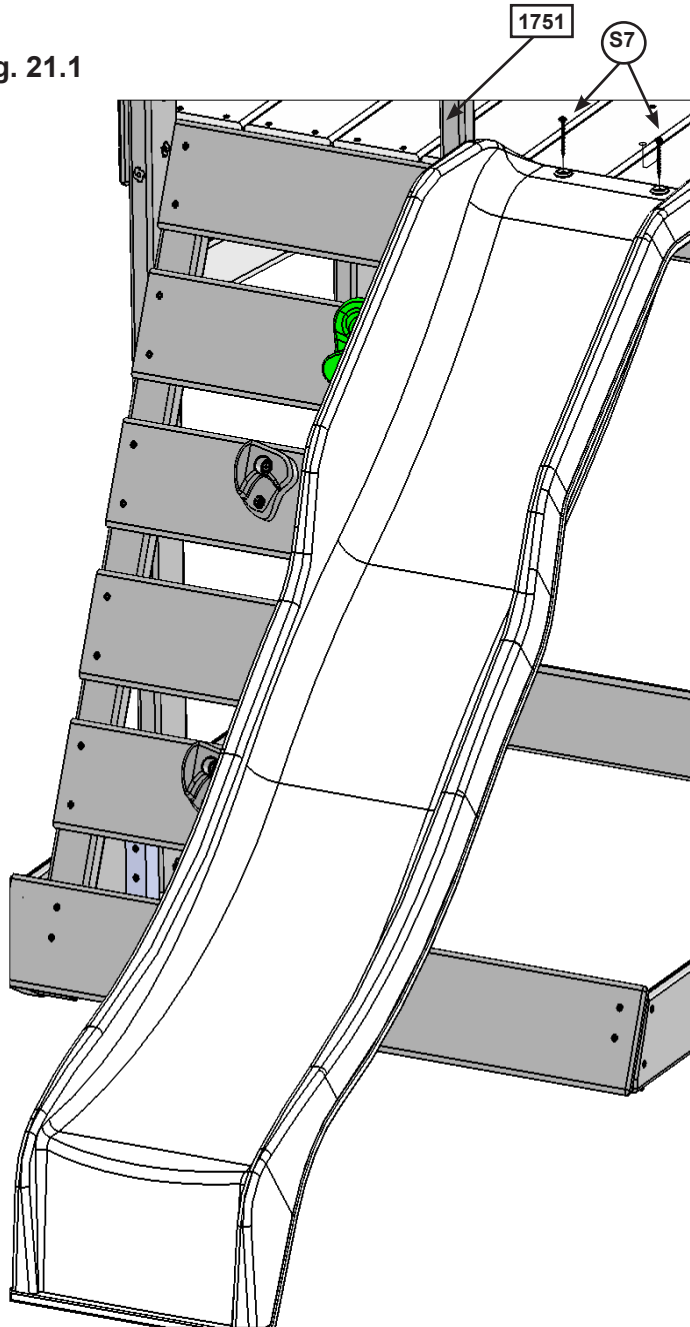
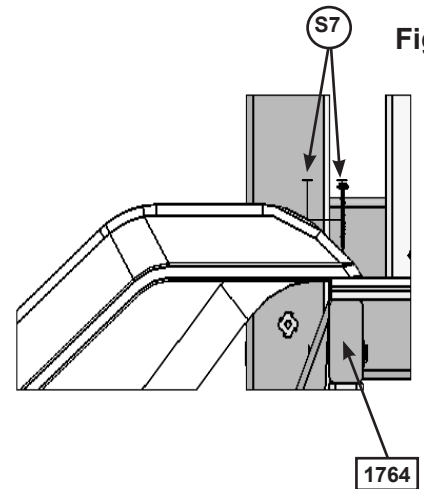

Fig. 21.2



Hardware

2 x (S7) #12 x 2" Pan Screw

Other Parts

1 x Slide

Step 22: Attach Swing To Fort

A: Attach Swing Assembly from Step 3 to (2782) SW Mount with 1 (G5) 5/16 x 4-1/2" Hex Bolt (with lock washer, flat washer and t-nut) and 1 (G8) 5/16 x 2" Hex Bolt (with 2 flat washers and 1 lock nut) as shown in fig. 22.1 & 22.2.

Fig. 22.1

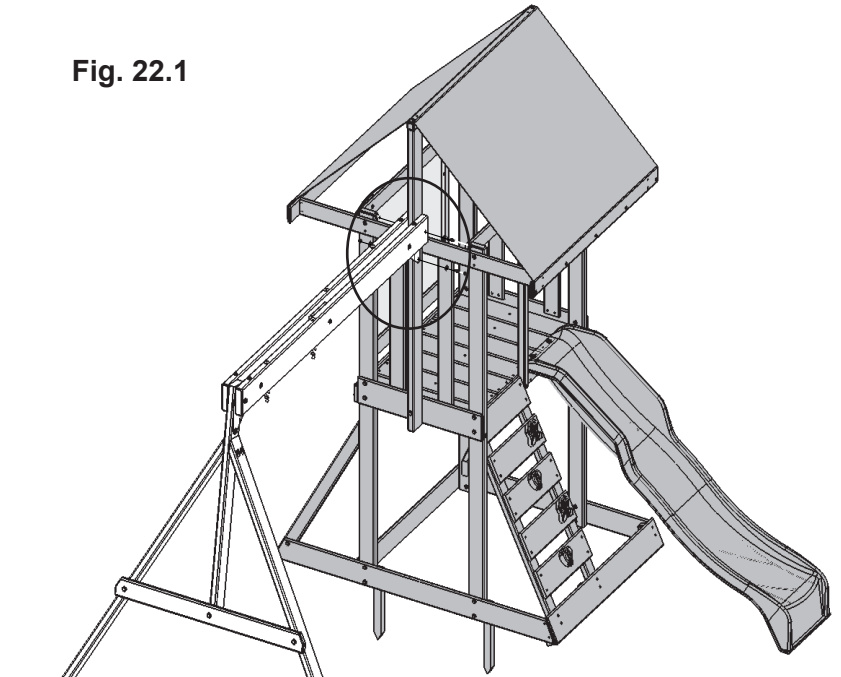
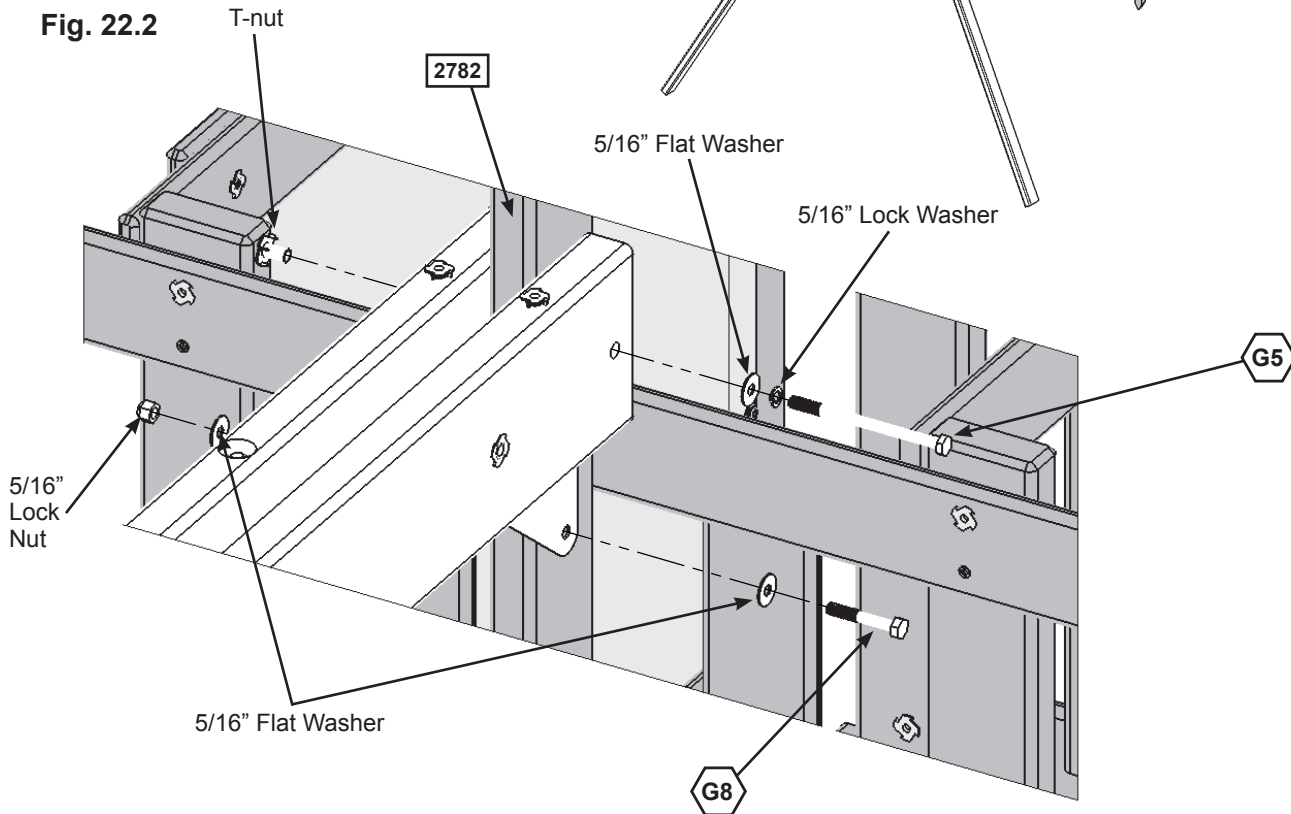



Fig. 22.2



Hardware

- 1 x  5/16 x 4-1/2" Hex Bolt
(5/16" lock washer, 5/16" flat washer, 5/16" t-nut)
- 1 x  5/16 x 2" Hex Bolt
(5/16" flat washer x2, 5/16" lock nut)

Step 23: Attach Swing End Ground Stakes and Swings

A: Drive 1 (0318) Ground Stake 10-1/2" into the ground at each (2803) SW Post on the inside of the assembly and attach with 2 (S3) #8 x 2-1/2" Wood Screws per ground stake. (fig. 23.1 & 23.2)

B: Attach 2 Belt Swings to the Bolt-Thru Swing Hangers. (fig. 23.1)

⚠WARNING: To prevent tipping and avoid potential injury, stakes must be driven 10-1/2" into ground. Digging or driving stakes can be dangerous if you do not check first for underground wiring, cables or gas lines.

Fig. 23.1

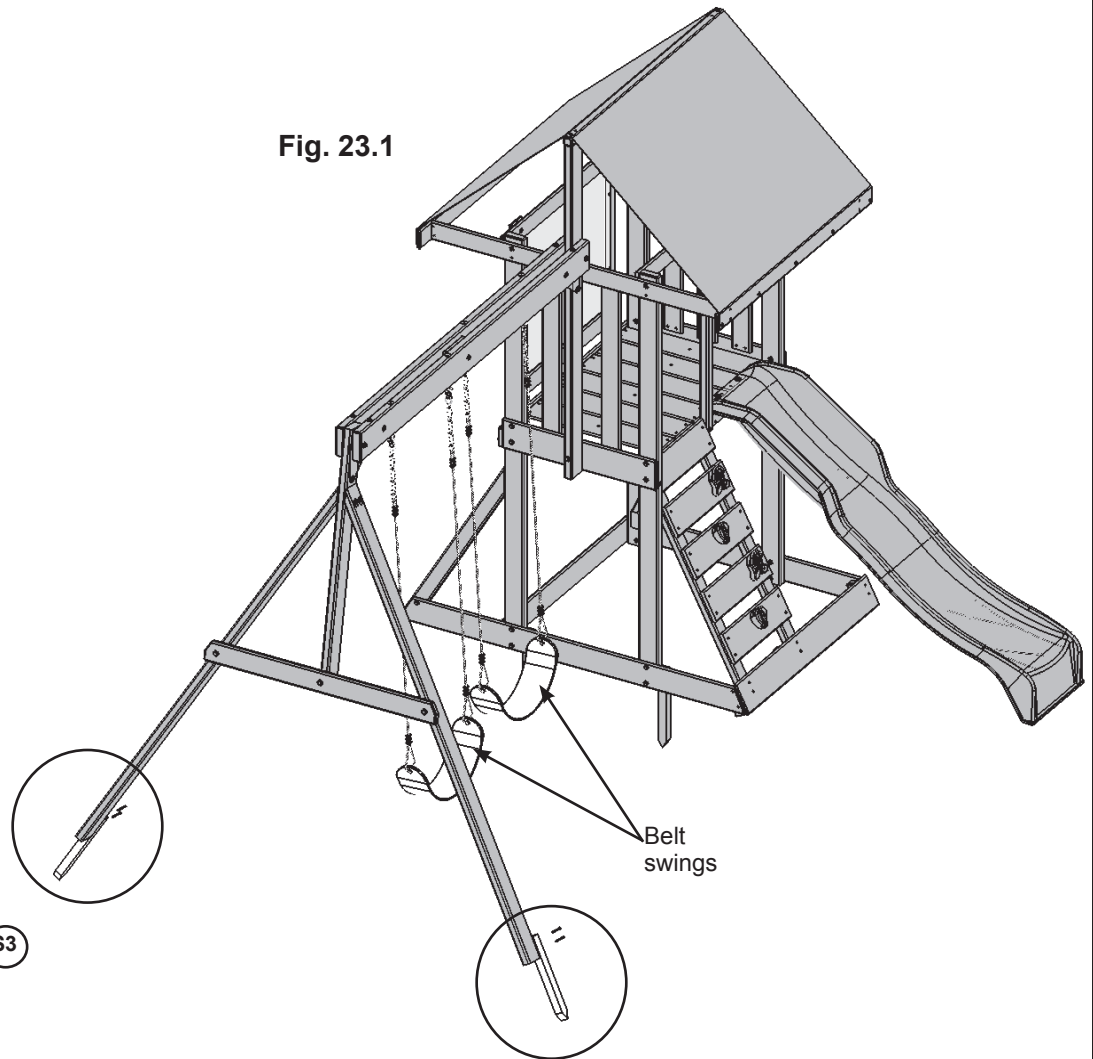
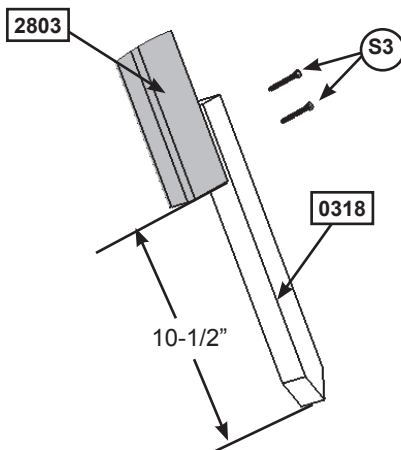

Fig. 23.2



Wood Parts

2 x 0318 Ground Stake 1 1/4 x 1 1/2 x 14"

Hardware

4 x S3 #8 x 2-1/2" Wood Screw

Other Parts

2 x Belt Swing

Final Step: Attach I.D. Plaque

ATTACH THIS WARNING & I.D. PLAQUE TO A PROMINENT LOCATION ON YOUR PLAY EQUIPMENT! (Fort or Swing Post)

This provides warnings concerning safety and important contact information. A Tracking Number is provided to allow you to get critical information or order replacement parts for this specific model.

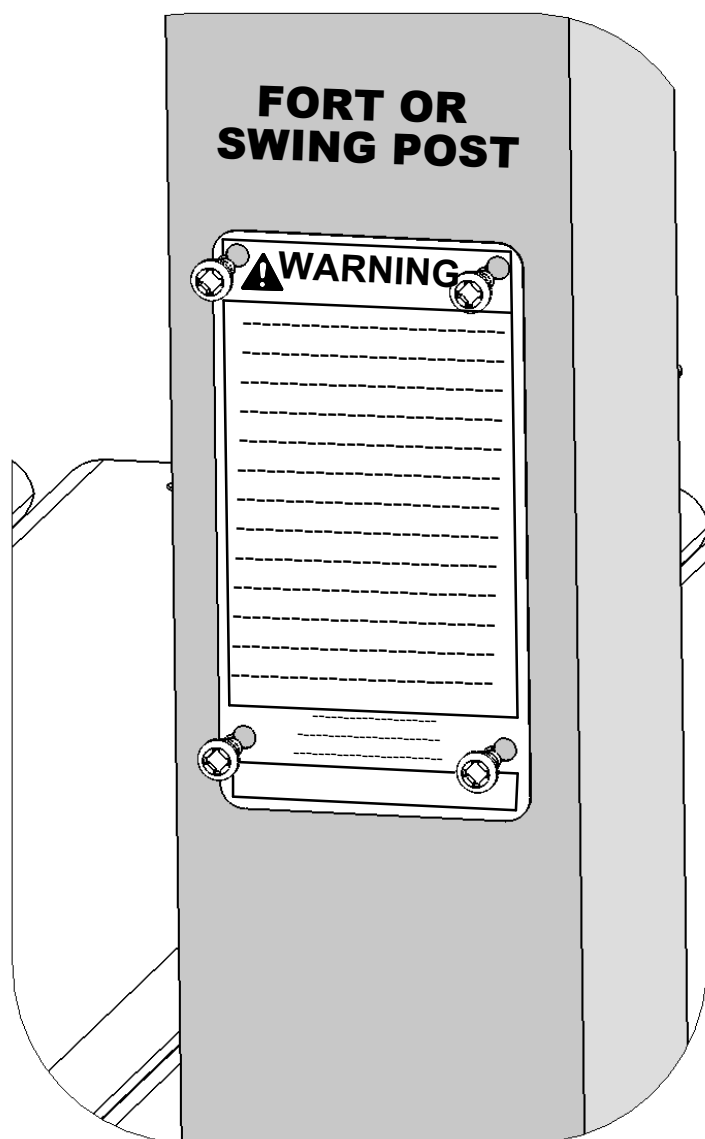

Attach with 4 (S5) #8 x 1/2" Pan Screws to a location on your set that is easily seen and read by a supervising adult.

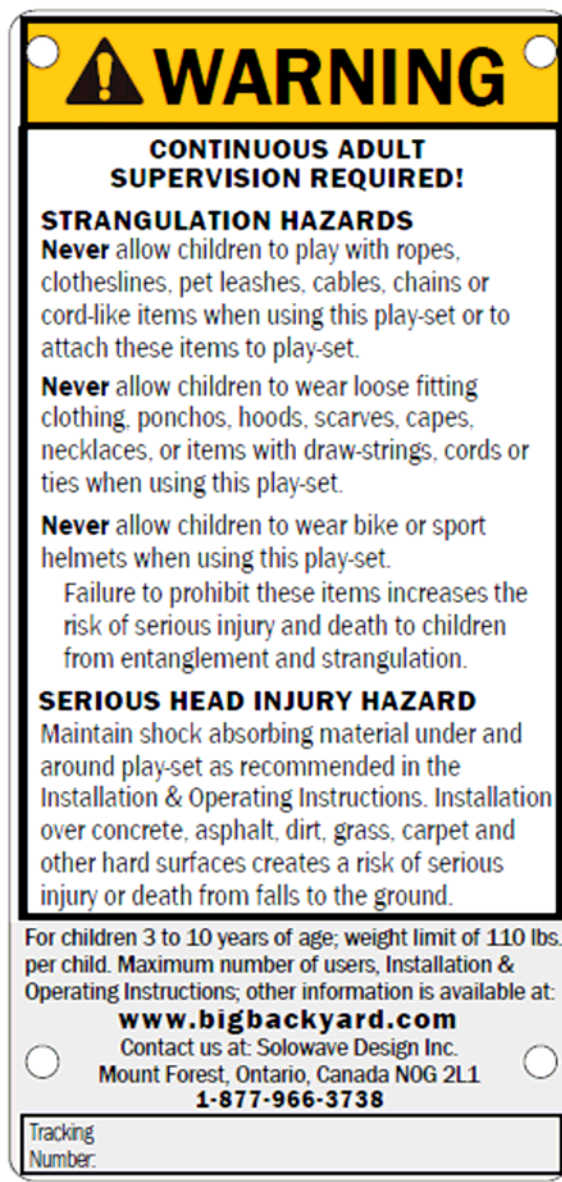

BIG BACKYARD
Consumer Registration Card

First Name Initial Last Name

--	--	--

Street Apt. No.

--	--

City State/Province ZIP/Postal Code

--	--	--	--

Country Telephone Number

--	--

E-Mail Address

--

Model Name Model Number (Box Labels)

--	--

Serial Number (on ID Plaque)

--

Date Purchase Purchased From

--	--

MM / DD / YY

How would you rate this product for quality?

Excellent Very Good Average Below Average Poor

How would you rate this product for ease of assembly?

Excellent Very Good Average Below Average Poor

How would you rate our instructions?

Excellent Very Good Average Below Average Poor

How would you rate the quality of packaging?

Excellent Very Good Average Below Average Poor

Would you recommend the purchase of our products to friends and family?

Yes No

Comments:

MAIL TO:
Solowave Design™
375 Sligo Road W.
Mount Forest, Ontario, Canada
NOG 2LO
Attention: Customer Service



Fill out your registration card online at
www.bigbackyard.com/ownerslounge
Big Backyard would like to say Thank You for
your time and feedback.