

1,250 LB. ENGINE STAND

Item Number W41031

OWNER'S MANUAL



Performance Tool®

▲WARNING: READ, UNDERSTAND AND FOLLOW ALL INSTRUCTIONS AND WARNINGS BEFORE OPERATING THIS TOOL. FAILURE TO DO SO MAY RESULT IN PERSONAL INJURY AND/OR PROPERTY DAMAGE AND WILL VOID WARRANTY.

PT[®]
Performance Tool

TOOL FEATURES

1. Head assembly rotates 360°
2. Adjustable mounting head
3. Metal parts tray
4. Heavy duty swivel casters
5. Heavy gauge tubular steel

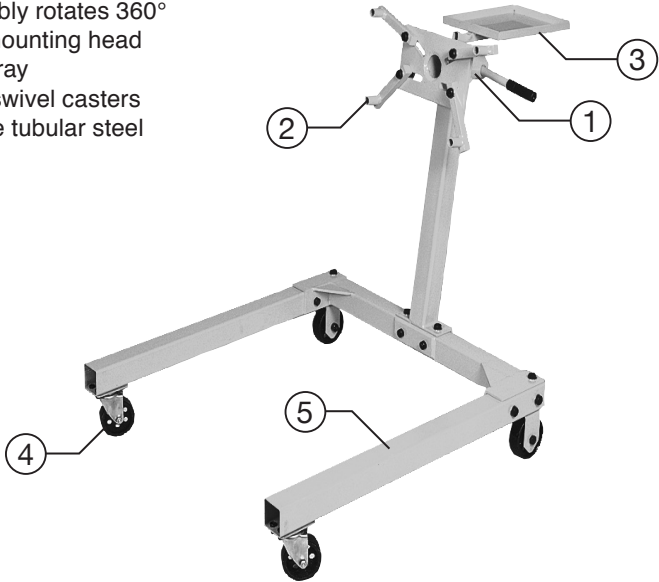

SPECIFICATIONS:

Capacity.....	1,250 lbs.
Length.....	34-1/4 in.
Width.....	33-7/16 in.
Height.....	35-5/8 in.

Specifications are subject to change without notice.

SAFETY GUIDELINES / DEFINITIONS

This instruction manual is intended for your benefit. Please read and follow the safety, installation, maintenance and troubleshooting steps described within to ensure your safety and satisfaction. The contents of this instruction manual are based upon the latest product information available at the time of publication. The manufacturer reserves the right to make product changes at any time without notice.

▲WARNING: Read and understand this entire instruction manual before attempting to assemble, install, operate or maintain this product. Failure to comply with the instructions may result in serious personal injury and/or property damage!

The following signal words are used to emphasize safety warnings that must be followed when using this product:

▲DANGER: Indicates an imminently hazardous situation that, if not avoided, WILL result in death or serious injury.

▲CAUTION: Indicates a potentially hazardous situation that, if not avoided, MAY result in minor or moderate injury.

▲WARNING: Indicates a potentially hazardous situation that, if not avoided, COULD result in death or serious injury.

NOTE: Indicates important information, which if not followed, MAY cause damage to equipment.

▲WARNING! Failure to heed these warnings may result in loss of load, damage to engine stand, and/or engine stand failure resulting in personal injury or property damage.

SAFETY INFORMATION CONT.

1. Always use common sense and pay particular attention to all the DANGER, WARNING, CAUTION and NOTICE statements of this manual. The safety instructions provided are not intended to cover all possible conditions and practices that may occur when operating, maintaining and cleaning power tools.
2. Observe work area conditions. Keep work area well lighted. Keep work area clean, well ventilated and well lit. Cluttered work areas invite accidents.
3. Use personal protective equipment. Wear ANSI approved safety goggles. Protective equipment such as dusk mask, non-skid safety shoes, hard hat, heavy duty work gloves or hearing protection used for appropriate conditions will reduce personal injuries.
4. Keep bystanders, children and visitors away while operating this product. Distractions can cause you to lose control.
5. Stay alert. Watch what you are doing, and use common sense when operating this tool. Do not use this product while tired or under the influence of drugs, alcohol, or medication. Keep proper footing and balance at all times.
6. Dress properly. Do not wear loose clothing or jewelry. Loose clothes, jewelry or long hair can be caught in moving parts.
7. Work Safe. Operate tool a safe distance from yourself and others in the work area. Keep proper footing and balance at all times. Do not reach over or across running machines, hoses, cords, etc.
8. Inspect tool before every use; do not use if parts are loose or damaged.
9. Do not alter this product in any way.
10. Use the right tool for the job. Do not attempt to force a small tool or attachment to do the work of a larger industrial tool. Don't use a tool whose performance is not adequate for your work. Do not modify this tool and do not use this tool for a purpose for which it was not intended.
11. DO NOT exceed rated capacity. Overloading can cause damage to or failure of this product.
12. Use only on hard, level surface capable of sustaining the load. Use of stand on other than hard level surfaces can result in stand instability and possible loss of load.
13. Always install rotational locking pin before applying load. Make sure the load is centered and secured to the mounting plate. Off center loads may make the load and handle rotate in either direction when the rotational locking pin is removed.
14. Keep clear of engine. Never work directly under a suspended engine.
15. Lock Support Plate mechanism before applying load.
16. Assure load is centered and secured to mounting attachments.
17. Do not attempt to move the Stand when under load. The Casters are not designed to be rolled when the Stand is supporting a heavy weight. If you need to move the engine, you must transfer it to an approved, appropriate moving device such as an engine hoist.
17. DO NOT use for aircraft purposes.
18. Industrial applications must follow OSHA requirements.
19. Store idle tools/equipment out of reach of children and other untrained persons. They are dangerous in the hands of untrained users.
20. Tool/equipment service must be performed only by qualified repair personnel. Service or maintenance performed by unqualified personnel could result in a risk of injury.
21. When servicing this product, use only identical replacement parts. Follow instructions in the Care & Maintenance section of this manual. Use of unauthorized parts or failure to follow maintenance instructions may create a risk of injury and may void any applicable warranty.
22. Maintain labels and nameplates on this product. These carry important information. If unreadable or missing, contact Performance Tool for a replacement.
23. The warnings, precautions, and instructions discussed in this manual cannot cover all possible conditions and situations that may occur. The operator must understand that common sense and caution are factors, which cannot be built into this product, but must be supplied by the operator.

UNPACKING AND INSPECTION

After opening the carton, unpack your new product and related parts & accessories. Please inspect it carefully for any damage that may have occurred during transit. Please check it against the photograph on carton. If any parts are missing, please call customer service at 1-800-426-1262 between 6:30 a.m. and 4:30 p.m. Pacific time.

▲ WARNING: DO NOT operate this product if damaged during shipment, handling or misuse. Do not operate the product until the parts have been replaced or the fault rectified. Failure to do so may result in serious personal injury or property damage. All damaged parts must be repaired or replaced as needed prior to operating this product. Check to see that all nuts, bolts and fittings are secure before putting this product into service. If you have any questions, or require assistance with damaged or missing parts, please contact our factory customer service department at: 1-800-426-1262.

Please have the serial number, model number, and date of purchase available for reference when calling.

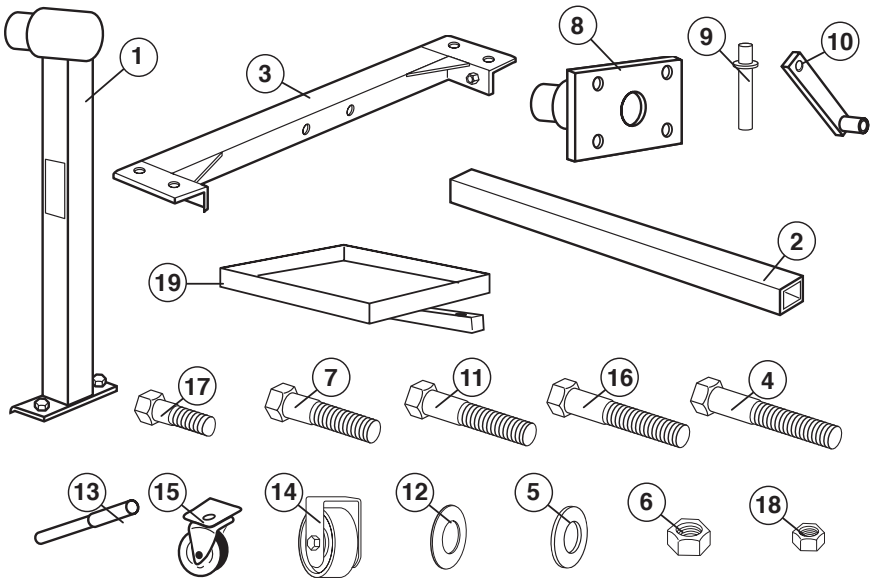

CONTENTS

No.	Description	Qty.	No.	Description	Qty.
1	Main Post.....	1	11	M12 x 50 Bolt.....	4
2	Side Legs	2	12	M12 Large Flat Washer	4
3	Rear Frame	1	13	Handle.....	1
4	M12 x 80 Bolt.....	8	14	Rear Wheels.....	2
5	M12 Washer	16	15	Front Caster Assembly	2
6	M12 Nut	14	16	M12 x 70 Bolt.....	2
7	M12 x 25 Bolt.....	2	17	M8 x 16 Bolt.....	8
8	Mounting Plate.....	1	18	M8 Nut	8
9	Locking Pin	1	19	Utility Tray	1
10	Mounting Arms	4			

ASSEMBLY INSTRUCTIONS

1. Attach side legs (2) to rear frame (3) with bolts (4) and (7), and washers (5) and nuts (6) as shown in Fig. 1.

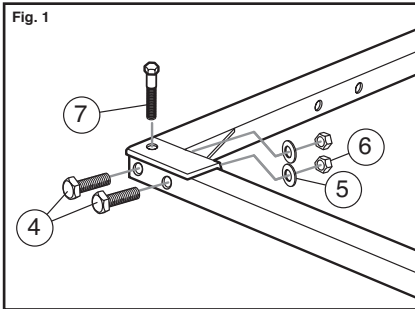

2. Attach main post (1) to rear frame with bolts, washers & nuts (4), (5) & (6) as shown in Fig. 2.

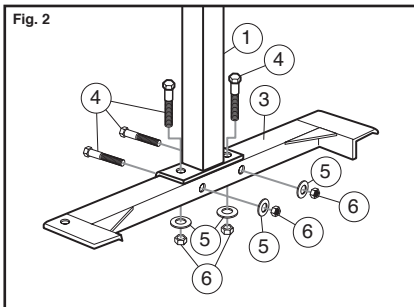

3. Insert head mounting plate (8) into collar at top of main post (1) and secure with lock pin (9) as shown in Fig. 3.

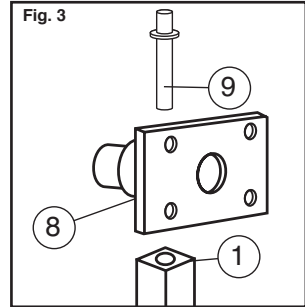

4. Attach mounting arms (10) to mounting plate (8) with nuts (6), bolts (11) & washers (12).

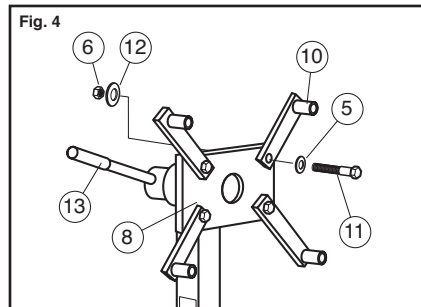

5. Screw in handle (13) to back of mounting plate (8) as shown in Fig. 4.

OPERATION INSTRUCTIONS

▲ CAUTION: Before applying load to stand, lock mounting plate with lock pin. (See part #9 on parts drawing.)

NOTE: Follow instructions in the vehicle's manual to determine the diameter and length of the bolts (not included) needed to connect your engine block to the Mounting Arms (10). Make sure you use bolts that are long enough to fit through the Holders and thread as deeply as possible into the engine block. Place the bolts (not included) through the Mounting Plate side (closest to the main post (4)) and securely tighten them into the engine block. The head of the bolts must be flush with the rear of the Holders. Use flat washers if necessary (not included.)

1. Using an appropriate engine lift or crane, lift the engine. Then transfer it to the Engine Stand and lower it until adjacent to the Mounting Plate (8).
2. Align the Short and Mounting Arms (10) with engine mounting bolt holes and

attach with appropriate bolts and tighten to the manufacturers specifications. Make a note of the engines incline, if any, which may be necessary for carrying the engine back to the vehicle for reinstallation.

OPERATION INSTRUCTIONS

- To rotate the engine, ALWAYS have at least one more person to assist. Be ready for sudden rotation of the engine. While holding onto the Handle (13) and the engine to prevent it from accidental rotation, remove Locking Pin (9). Slowly rotate the engine to the desired angle and insert the Locking Pin (9) into the Collar. It may be necessary to rotate the engine back and forth slightly to align the hole in the Collar and the ones of the Mounting Post. The Locking Pin must be pushed all the way in to engage both at the top and at the bottom end of the Collar.
- Prior to dismounting the engine block from the Stand, with the assistance of a helper, rotate the engine to its initial installation position.
- When finished working on the engine, follow the safety warnings and instructions that came with the engine hoist to safely remove the engine from the Stand.

CARE AND MAINTENANCE

▲ WARNING: Before each use, inspect the general condition of the stand. If stand appears to be damaged in any way, remove from service immediately.

- Before each use, inspect the general condition of the stand. Check for broken, cracked, or bent parts, loose or missing parts, and any condition that may affect the proper operation of the equipment. Any stand that appears damaged in anyway must be removed from service. Have the problem corrected before further use. DO NOT use damaged equipment.
- Replace worn or damaged parts with Performance Tool® replacement parts. Be sure that only qualified personnel perform repairs.
- Before each use, thoroughly test the stand for proper operation prior to its actual use.
- Keep stand clean and well lubricated.

EXPANDED PARTS LIST

No.	Description	Qty.	No.	Description	Qty.
1	Main Post.....	1	12	M12 Large Flat Washer.....	4
2	Side Legs.....	2	13	Handle.....	1
3	Rear Frame.....	1	14	Rear Wheels.....	2
4	M12 x 25 Bolt.....	8	15	Front Caster Assembly.....	2
5	M12 Washer.....	16	16	M12 x 70 Bolt.....	2
6	M12 Nut.....	14	17	Bushing.....	2
7	M12 x 25 Bolt.....	2	18	Spacer.....	4
8	Mounting Plate.....	1	19	M8 x 16 Bolt.....	8
9	Locking Pin.....	1	20	M8 Nut.....	8
10	Mounting Arms.....	4	21	Utility Tray.....	1
11	M12 x 50 Bolt.....	4			

DIAGRAM

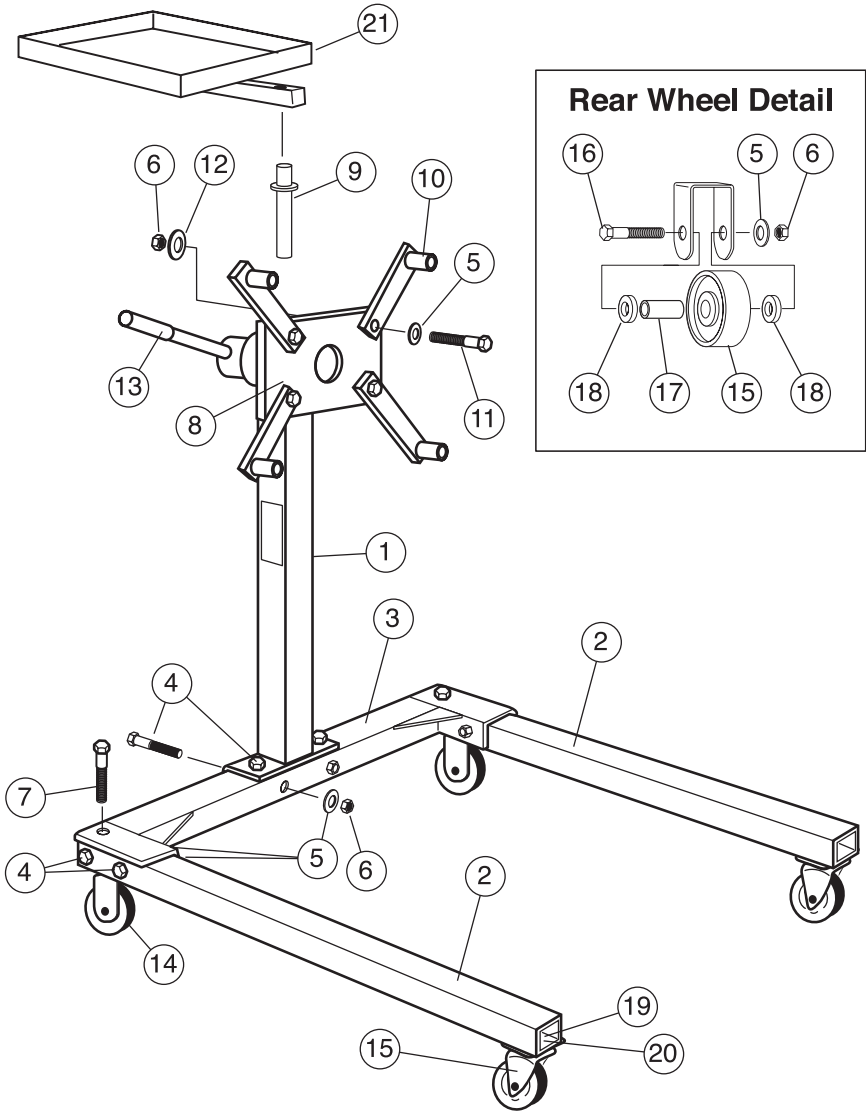

1 YEAR WARRANTY

PERFORMANCE TOOL® extends only the following warranties, and only to original retail purchasers. These warranties give specific legal rights. Except where prohibited by local law, the law of the State of Washington governs all warranties and all exclusions and limitations of warranties and remedies. There may be other rights which vary from state to state.

PERFORMANCE TOOL® warrants the product to be free from defects in materials and workmanship under normal use and service. A defective product may be returned for a free replacement within 90 days from the date of purchase, provided that product is returned to place of purchase immediately after discovery of defect. After 90 days and up to one year from date of purchase, PERFORMANCE TOOL® will replace at no charge any parts which our examination shall disclose to be defective and under warranty. These warranties shall be valid only when a sales receipt showing the date of purchase accompanies the defective product or defective part (s) being returned. For part (s) after 90 days, please remit your request, postage prepaid to:

PERFORMANCE TOOL, P.O. Box 88259 Tukwila, WA 98138

These warranties exclude blades, bits, punches, dies, bulbs, fuses, hoses, and other consumables which must be replaced under normal use and service. These warranties shall not apply to any product or part which is used for a purpose for which it is not designed, or which has been repaired or altered in any way so as to affect adversely its performance or reliability, nor shall these warranties apply to any product or part which has been subject to misuse, neglect, accident or wear and tear incident to normal use and service.

PERFORMANCE TOOL® does not authorize any other person to make any warranty or to assume any liability in connection with its products.

Except for warranties of title and the limited express warranties set forth above, PERFORMANCE TOOL® makes no express or implied warranties of any kind with respect to its products. In particular, PERFORMANCE TOOL® makes no implied warranty of merchantability and no implied warranty of fitness for any particular purpose, except that for goods purchased primarily for personal, family or household use and not for commercial or business use, PERFORMANCE TOOL® makes an implied warranty of merchantability (and, if otherwise applicable, an implied warranty of fitness for a particular purpose), but only for the particular qualities or characteristics, and for the duration, expressly warranted above.

The laws on limitation of implied warranties may differ from state to state, so the above limitations may not apply in all cases.

PERFORMANCE TOOL® shall not be liable for consequential, incidental or special damages resulting from or in any manner related to any product, or to the design, use, or any inability to use the product. The sole and exclusive remedy for a defective product or part shall be the repair, or replacement thereof as provided above. The laws on limitation of remedies or on consequential, incidental or special damages may vary from state to state, so the above limitations may not apply in all cases.