

INSTRUCTION MANUAL

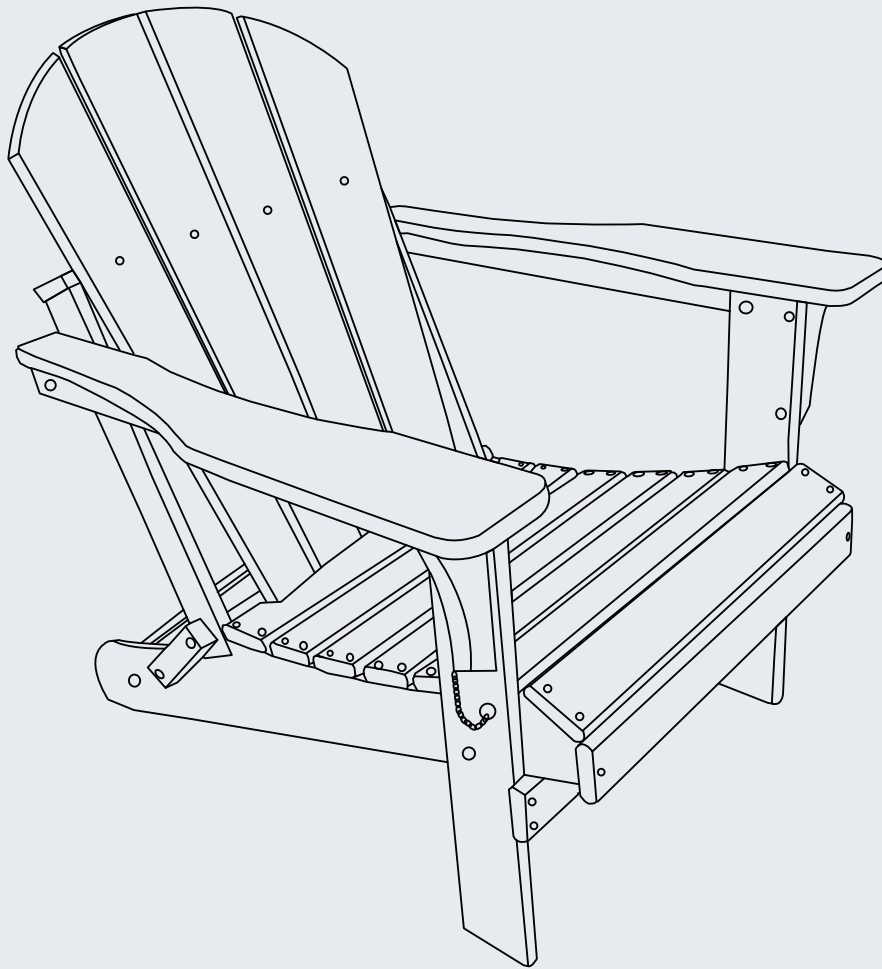

Outdoor Folding Poly Adirondack Chair

V2.0

⚠ NOTICE

Do not overtighten screws. (Insert all screws before tighten screws.)

- Please do not exceed the weight limitations of this item.
- Do not stand on or use any part of this item as a step ladder.
- Firmly secure all bolts, screws and nuts before use.
- Reconfirm that all bolts, screws, and nuts are secure every 90 days.
- Do not use or store this item in the proximity of open flame or flammable/combustible chemicals.
- Be aware that some parts are heavy and have sharp edges.
- Be very careful when folding chair to avoid smashing your hands or fingers.

TOOLS REQUIRED

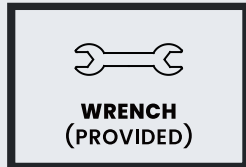
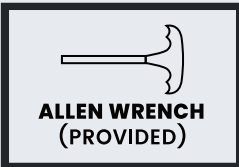

HARDWARE

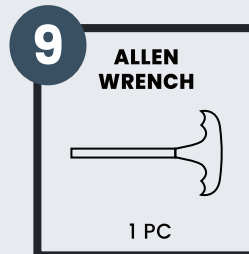
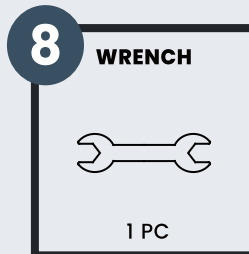
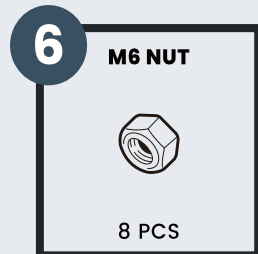
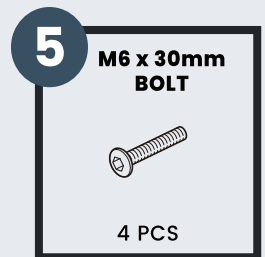
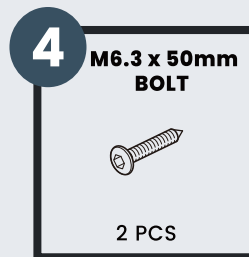
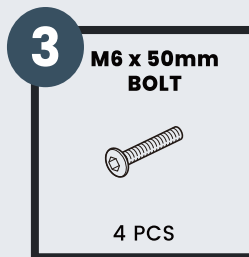
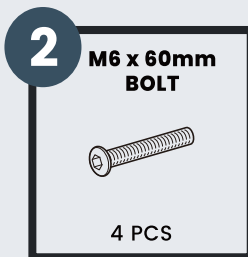
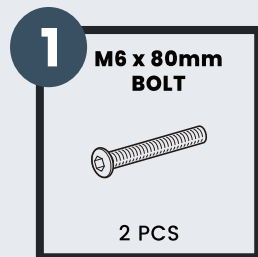

PARTS

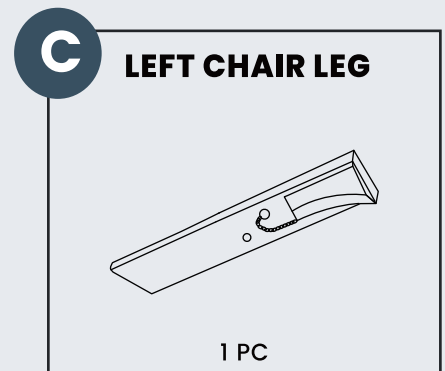
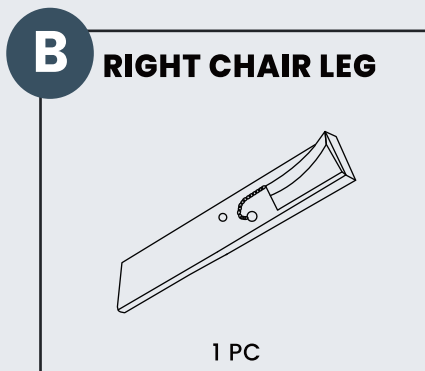
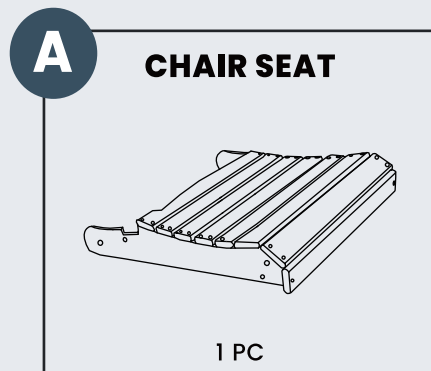

PARTS

D RIGHT CHAIR ARM



1 PC

E LEFT CHAIR ARM



1 PC

F CHAIR BACKREST

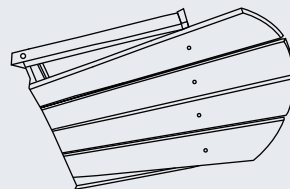

1 PC

G BACK RAIL

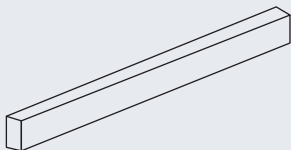

1 PC

H FRONT RAIL



1 PC

I LOCKING BLOCK



2 PCS

PRODUCT ASSEMBLY - OVERALL VIEW

- 1** Look at following overall view of this chair and learn the exact position of each parts to be assembled.

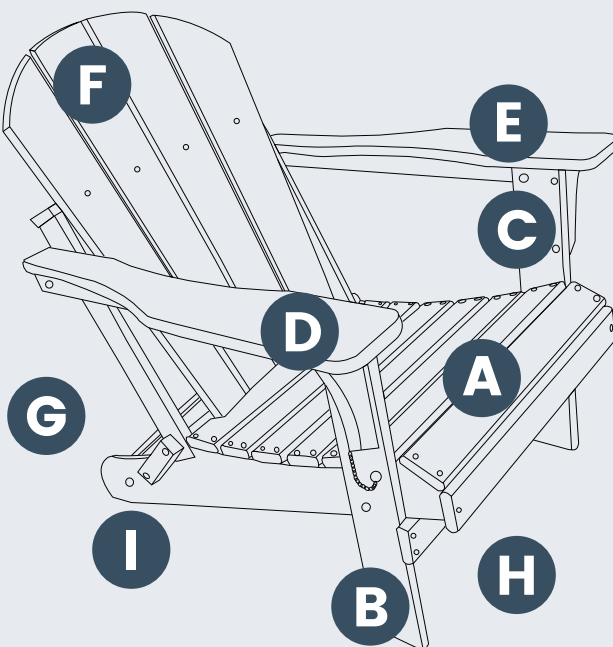

PRODUCT ASSEMBLY

1

Attach **Part C Left Chair Leg** to **Part E Left Chair Arm** with 1 pc of **Hardware #2 Bolt** and **Hardware #7 Washer** and **Hardware #6 Nut**. Do same to **Part B Right Chair Leg** and **Part D Right Chair Arm**.

Attach the locking stick to chair legs with a screw driver before assembly.

Do not tighten screws too much at this stage.

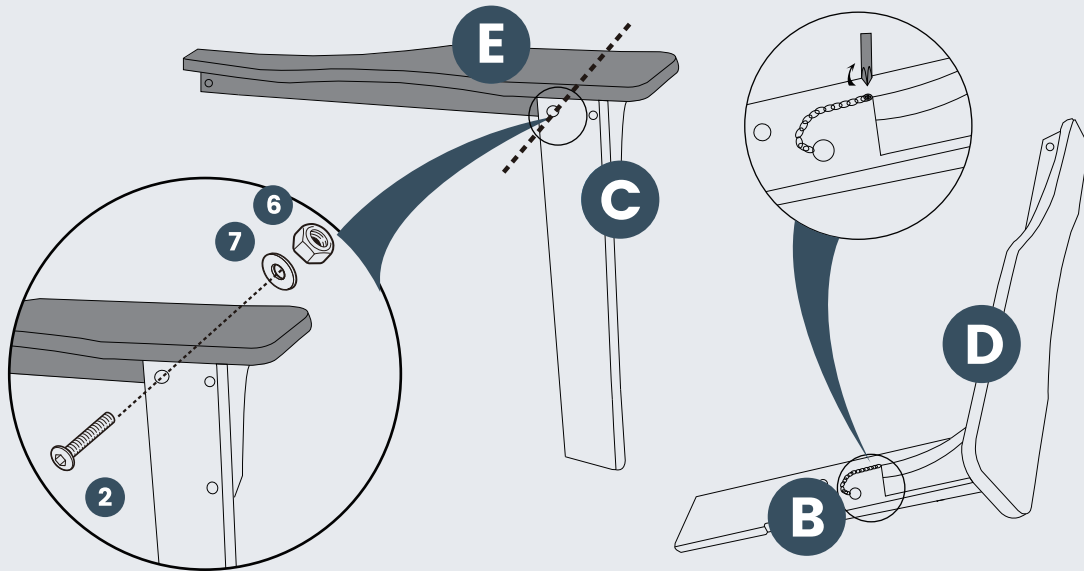

2

Attach **Part B Right Chair Leg** and **Part C Left Chair Leg** to **Part A Chair Seat** with 2 pcs of **Hardware #2 Bolt** and **Hardware #7 Washer** and **Hardware #6 Nut**.

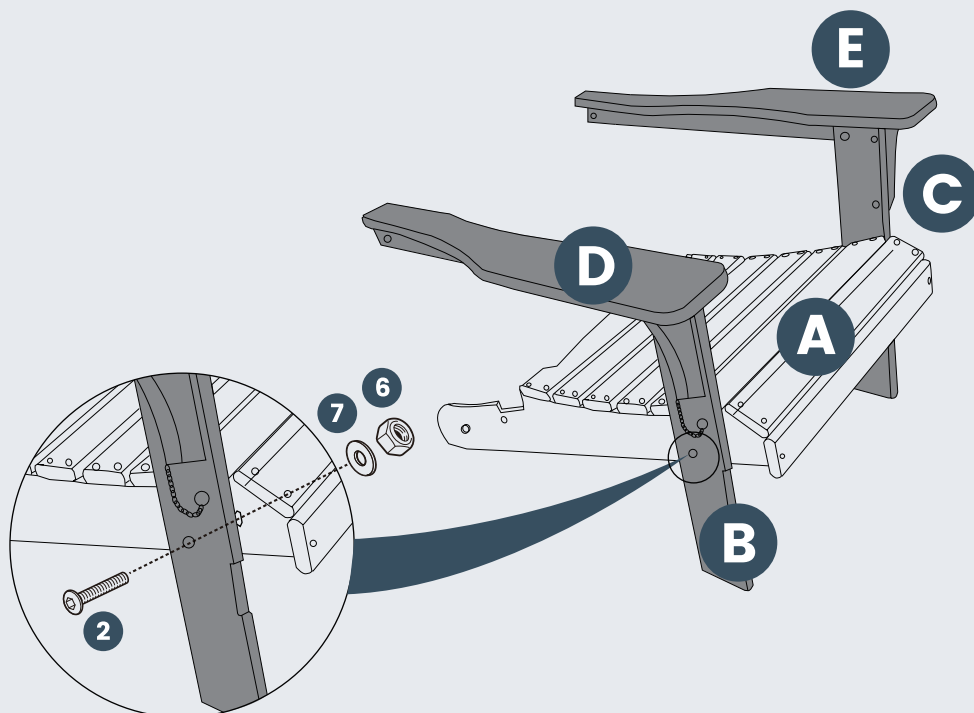

PRODUCT ASSEMBLY

3

Fix **Part F Backrest** into **Part A Chair Seat** and then attach **Part F Chair Backrest** to **Part D Right Chair Arm** with 1 pc of **Hardware #1 Bolt** and **Hardware #7 Washer** and **Hardware #6 Nut**.

Do the same to attach **Part F Backrest** to **Part E Left Chair Leg**.

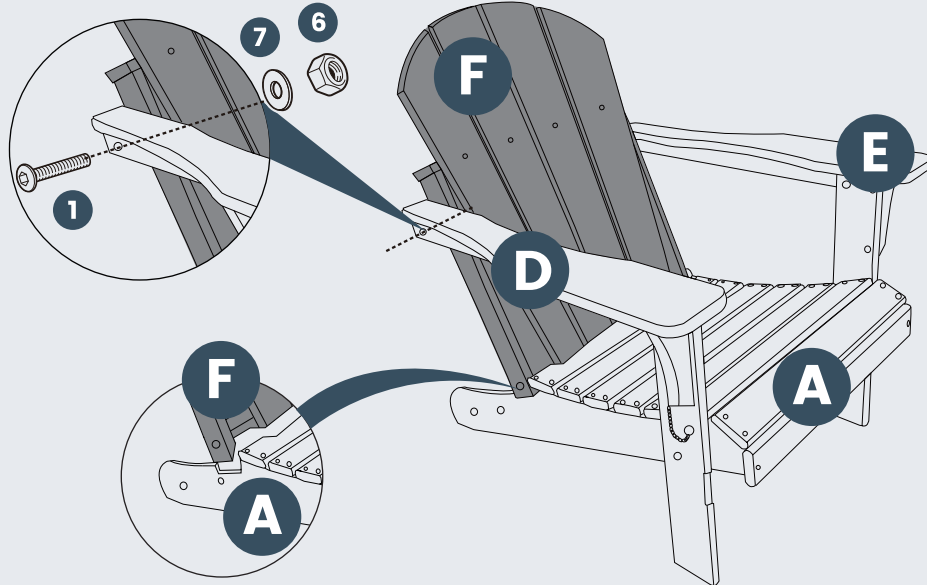

4

Attach **Part I Locking Blocks** to **Part F Chair Backrest** (both sides) with 2 pcs of **Hardware #4 Bolt** and attach **Part I Locking Blocks** to **Part A Chair Seat** (both sides) with 2 pcs of **Hardware #3 Bolt** and **Hardware #7 Washer** and **Hardware #6 Nut**.

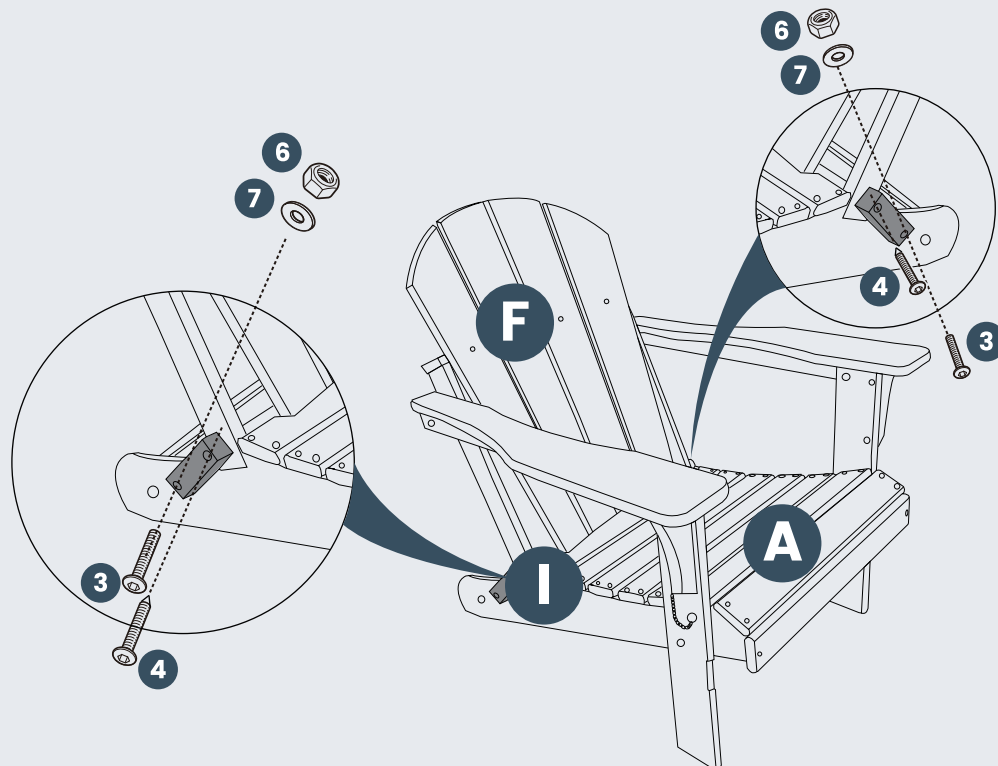

PRODUCT ASSEMBLY

5

Attach **Part G Back Rail** to **Part A Chair Seat** with 2 pcs of **Hardware #3 Bolt**.

Attach **Part H Front Rail** to **Part B Left Chair Leg** and **Part C Right Chair Leg** with 4 pcs of **Hardware #5 Bolt**.

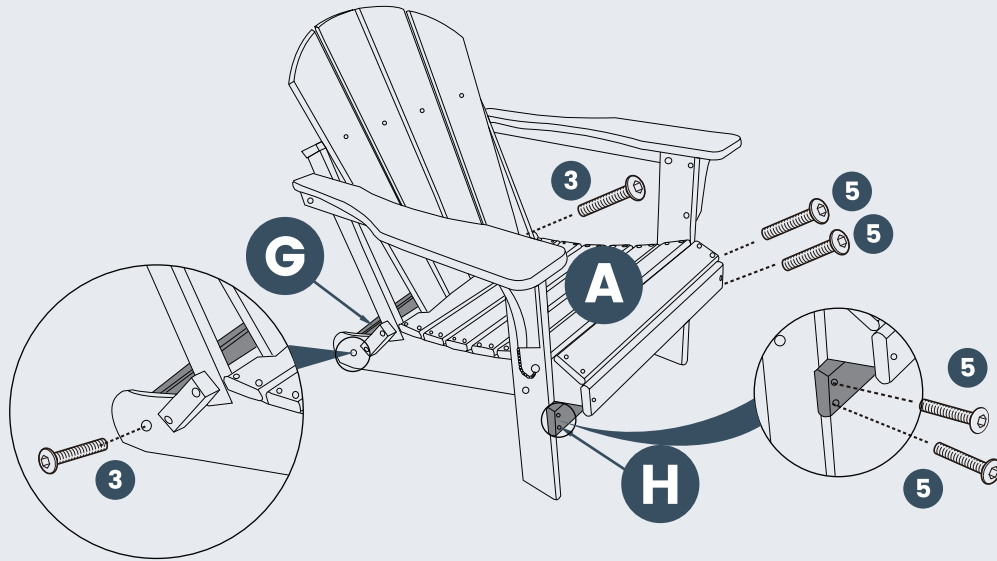

Congratulations! You finished the assembly of this chair.

Pull the stick out of both legs to fold this chair as below.

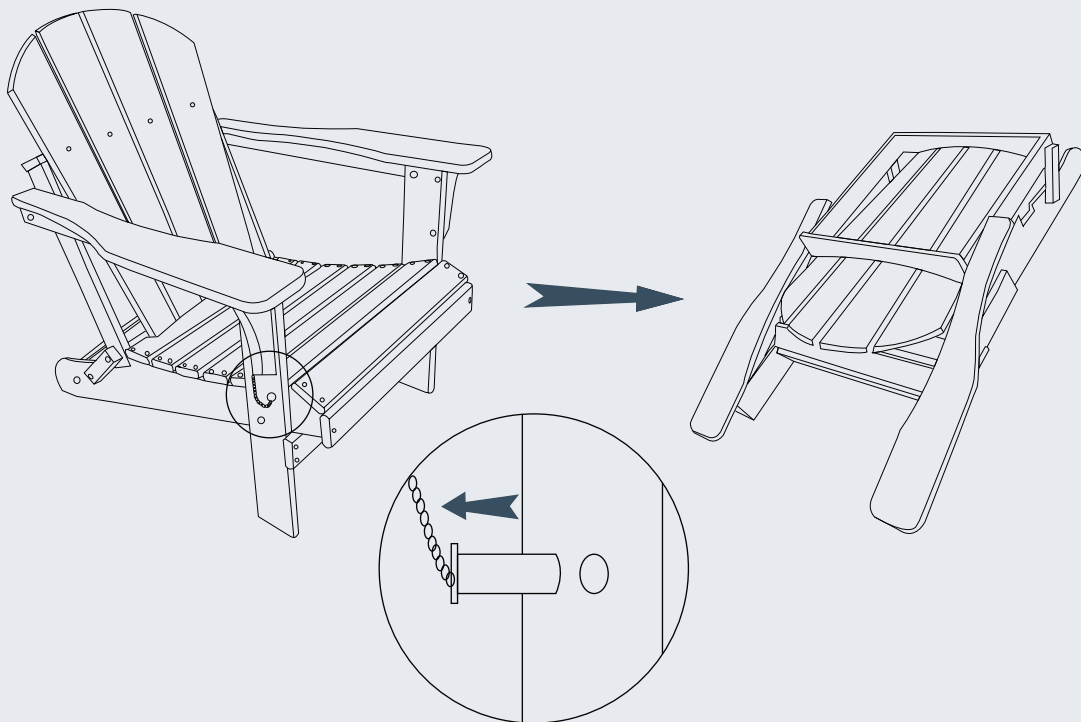

CLEANING TIPS

REGULAR CLEAN: Use a mixture of warm water and mild soap. Gently scrub the surface with a soft bristle brush to remove any dirt or stains.

QUICK CLEAN: You can simply wipe down the furniture with a damp cloth.

Regular cleaning not only preserves the aesthetic appeal of your furniture, but also helps extend its lifespan.