

# LUXURY GELCOAT SERIES

## SUBMITTAL DATA

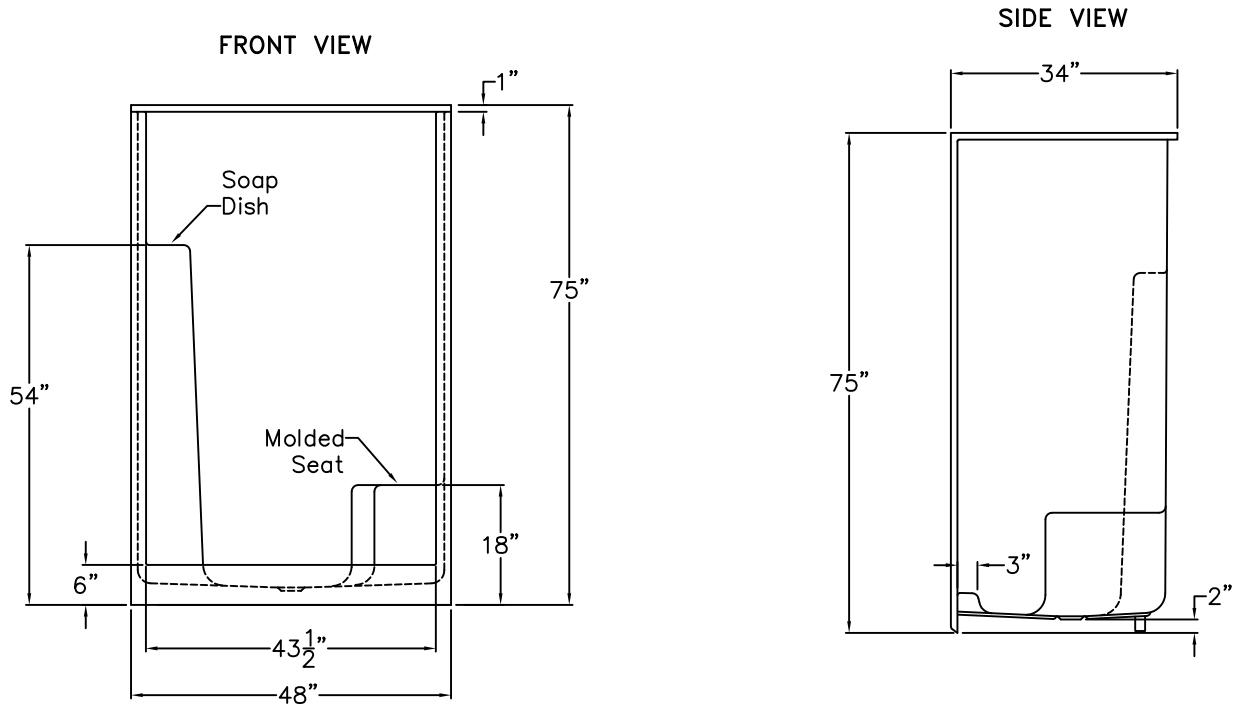

### Smooth Wall Gelcoat Shower

The shower enclosure shall be Praxis Model S676 Right. Finished surface shall be of a sanitary-grade polyester Gelcoat exhibiting a minimal thickness of 15 dry mills, and a finished cured Barcol hardness of 80-90 as tested with ASTM D-2583. Unit construction shall be of molded reinforced fiberglass with a 15% minimum fiberglass content. The base shall be attached to the sump of the unit in such a manner to form an integral part with an inner and outer coating of reinforced polyester resin. The unit shall meet HUD, FHA, BOCA, CSA B45.5, IAPMO Z124-11, Home Innovation Research Lab, UPC, and shall meet the requirements of the Southern Building Code.

The unit shall have outside dimensions of 75" x 48" x 34".

The enclosure shall be equipped with the following factory installed accessories:

- 1) One molded soap tray,
- 2) One molded seat on the right side,
- 3) 6" Threshold.

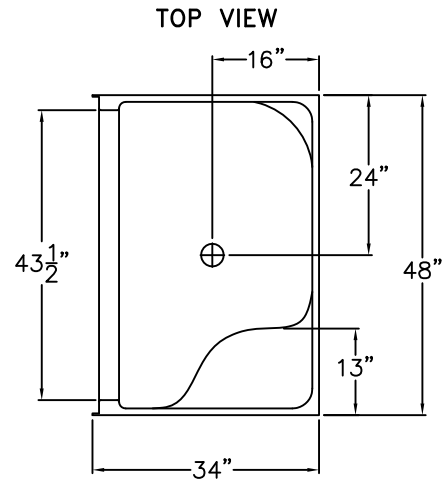

DUE TO THE NATURE OF THE MATERIALS  
DIMENSIONS MAY VARY ± 1/2"

Model:	PRAXIS
Approved by Print Name:	Drawing#: S676
Approved by Signature:	Date Approved: Date: 7-18-96 Revised: 6-4-14
Rep.:	Wholesaler: Quote No.:

PRAXIS INDUSTRIES, INC.  
435 INDUSTRIAL RD - SAVANNAH, TN 38372  
1 (800) 443-7269 - FAX (901) 925-4290