

# Ceiling Fan Installation Manual



P2502

## ***PROGRESS LIGHTING 15-Year Limited Warranty***

PROGRESS LIGHTING FAN MOTORS ARE WARRANTED TO THE END USER TO BE FREE OF ELECTRICAL AND/OR MECHANICAL DEFECTS FOR A PERIOD OF 15 YEARS FROM DATE OF SALE. PULL CHAIN SWITCHES, REVERSE SWITCHES, CAPACITORS AND METAL FINISHES ARE WARRANTED FOR A PERIOD OF 1 YEAR. WARPING OF WOODEN OR PLASTIC BLADES IS NOT COVERED BY THIS WARRANTY.

THE END USER HAS THE OPTION OF RETURNING THE DEFECTIVE FAN TO THE PLACE OF PURCHASE DURING THE FIRST 30 DAYS FOR A REPLACEMENT. AFTER 30 DAYS, THE PURCHASER MUST CONTACT PROGRESS LIGHTING FOR REPAIR OR REPLACEMENT. THE END USER ALSO BEARS THE RESPONSIBILITY FOR ALL COSTS IN THE REMOVAL, SHIPPING AND REINSTALLATION OF FANS OR PARTS FOR REPAIR OR REPLACEMENT.

PROGRESS LIGHTING WILL NOT ASSUME LIABILITY OR RESPONSIBILITY FOR DAMAGES (INCLUDING INCIDENTAL OR CONSEQUENTIAL) CAUSED BY THE IMPROPER INSTALLATION OR OPERATION OF THE UNIT OR ITS COMPONENT PARTS, OR BY THE FAILURE OF SUPPORTING HARDWARE NOT SUPPLIED BY PROGRESS LIGHTING. THIS WARRANTY IS GIVEN IN LIEU OF ALL OTHER GUARANTEES, WHETHER EXPRESSED OR IMPLIED, AND IS VOIDED IN CASES OF ABUSE, MISUSE OR IMPROPER HANDLING, NEGLIGENCE, SHIPPING DAMAGE, UNAUTHORIZED REPAIRS (MADE OR ATTEMPTED) OR UNUSUAL APPLICATION.

SOME STATES DO NOT ALLOW LIMITATIONS ON HOW LONG AN IMPLIED WARRANTY LASTS OR THE EXCLUSION OR LIMITATIONS OF INCIDENTAL OR CONSEQUENTIAL DAMAGES, SO THE ABOVE LIMITATIONS AND EXCLUSIONS MAY NOT APPLY TO YOU. THIS WARRANTY GIVES YOU SPECIFIC RIGHTS AND YOU MAY HAVE OTHER RIGHTS WHICH VARY FROM STATE TO STATE.



# *15-Year Limited Warranty*

Date Purchased \_\_\_\_\_

Store Purchased \_\_\_\_\_

Model No. \_\_\_\_\_ EF200D

Serial No. \_\_\_\_\_

Vendor No. \_\_\_\_\_ 5523

UPC \_\_\_\_\_ 785247 250219

\_\_\_\_\_ 785247 114511

\_\_\_\_\_ 785247 149339

\_\_\_\_\_ 785247 161461

Safety Rules .....	Page 1
Unpacking Your Fan .....	Page 2
Installing Your Fan .....	Page 3
Operating Your Fan .....	Page 10
Care of Your Fan/Specifications.....	Page 11
Troubleshooting .....	Page 12

## *Table of Contents*

## READ AND SAVE THESE INSTRUCTIONS

1. To reduce the risk of electric shock, insure electricity has been turned off at the circuit breaker or fuse box before beginning.
2. All wiring must be in accordance with the National Electrical Code and local electrical codes. Electrical installation should be performed by a qualified licensed electrician.
3. **WARNING:** To reduce the risk of electrical shock and fire, do not use this fan with any solid-state fan speed control device.
4. **CAUTION:** To reduce the risk of personal injury, use only the screws provided with the outlet box.
5. The outlet box and support structure must be securely mounted and capable of reliably supporting a minimum of 35 pounds. Use only UL Listed outlet boxes marked "FOR FAN SUPPORT."
9. To avoid personal injury or damage to the fan and other items, be cautious when working around or cleaning the fan.
10. Do not use water or detergents when cleaning the fan or fan blades. A dry dust cloth or lightly dampened cloth will be suitable for most cleaning.
11. After making electrical connections, spliced conductors should be turned upward and pushed carefully up into outlet box. The wires should be spread apart with the grounded conductor and the equipment-grounding conductor on one side of the outlet box and ungrounded conductor on the other side of the outlet box.
12. Suitable for Use In Wet Locations When Installed In A GFCI Protected Branch Circuit.

**This Fan is suitable for wet location.**

### WARNING

TO REDUCE THE RISK OF FIRE, ELECTRIC SHOCK OR PERSONAL INJURY, MOUNT FAN TO OUTLET BOX MARKED ACCEPTABLE FOR FAN SUPPORT WITH THE SCREWS PROVIDED WITH THE OUTLET BOX.

6. The fan must be mounted with a **minimum of 7 feet clearance** from the trailing edge of the blades to the floor.
7. Do not operate reversing switch while fan blades are in motion. Fan must be turned off and blades stopped before reversing blade direction.
8. Avoid placing objects in the path of the blades.

### WARNING

TO REDUCE THE RISK OF PERSONAL INJURY, DO NOT BEND THE BLADE BRACKETS (ALSO REFERRED TO AS "FLANGES") DURING ASSEMBLY OR AFTER INSTALLATION. DO NOT INSERT OBJECTS IN THE PATH OF THE BLADES.

### IMPORTANT

PLEASE REMOVE RUBBER MOTOR STOPS ON THE BOTTOM OF THE FAN BEFORE INSTALLING BLADES OR TESTING MOTOR

### WARNING

THIS PRODUCT CONTAINS CHEMICALS KNOWN TO THE STATE OF CALIFORNIA TO CAUSE CANCER, BIRTH DEFECTS AND/OR OTHER REPRODUCTIVE HARM. THOROUGHLY WASH HANDS AFTER INSTALLING, HANDLING, CLEANING, OR OTHERWISE TOUCHING THIS PRODUCT.

# 1. Safety Rules

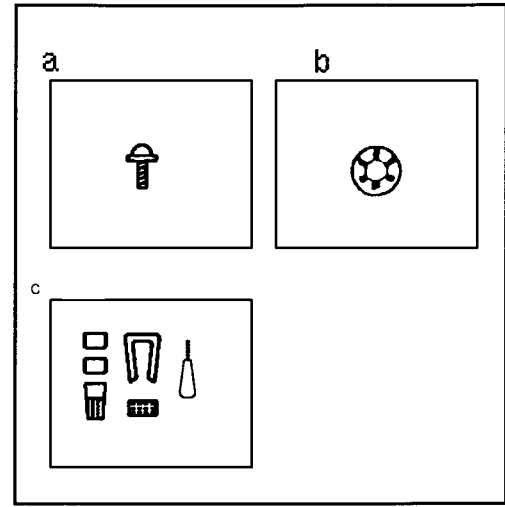
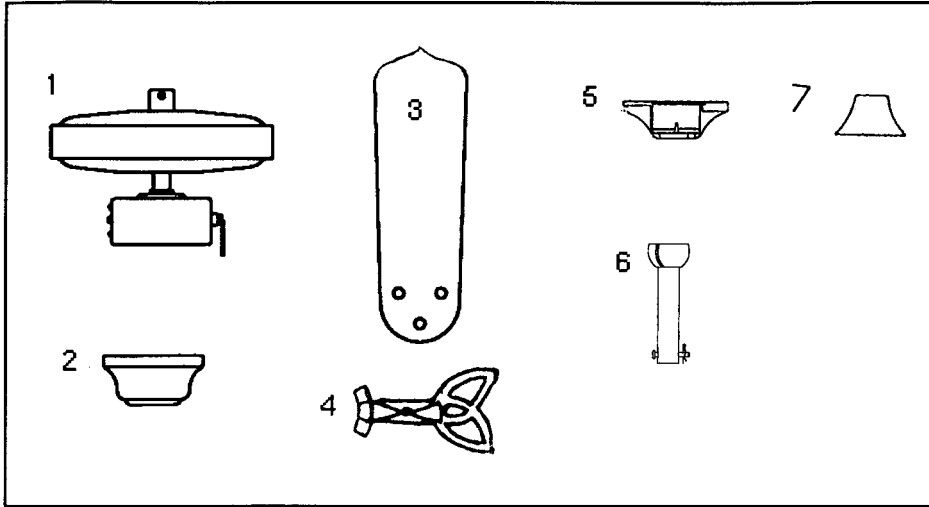

Unpack your fan and check the contents. You should have the following items:

1. Fan Motor Assembly
2. Canopy
3. Blades (5)
4. Blade Bracket Set (5)  
(with blade bracket screws pre-installed)
5. Slide-On Mounting Plate (located inside canopy) and Mounting Hardware
6. Ball/Downrod Assembly (1)  
(with bolt and clevis pin pre-attached)
7. Motor collar cover

- a. **Blade attachment hardware**  
(15 washer head screws)
- b. **Mounting hardware** (1 rubber gasket).
- c. **Electrical hardware & Balancing Kit**  
(3 plastic wire connectors, 1 Pull Chain blade balancing kit).

**IMPORTANT**

PLEASE REMOVE RUBBER MOTOR STOPS ON THE BOTTOM OF THE FAN BEFORE INSTALLING BLADES OR TESTING MOTOR

## *Unpacking Your Fan 2.*

## Tools Required

Phillips screw driver, straight slot screw driver, adjustable wrench, step ladder, and wire cutters.

## Mounting Options

If there isn't an existing mounting box, then read the following instructions. Disconnect the power by removing fuses or turning off circuit breakers.

Secure the outlet box directly to the building structure. Use appropriate fasteners and building materials. The outlet box and its support must be able to fully support the moving weight of the fan (at least 35 lbs.). Do not use plastic outlet boxes.

**WARNING**  
TO REDUCE THE RISK OF FIRE, ELECTRIC SHOCK, OR OTHER PERSONAL INJURY, MOUNT FAN ONLY TO AN OUTLET BOX MARKED ACCEPTABLE FOR FAN SUPPORT AND USE THE MOUNTING SCREWS PROVIDED WITH THE OUTLET BOX. OUTLET BOXES COMMONLY USED FOR THE SUPPORT OF LIGHTING FIXTURES MAY NOT BE ACCEPTABLE FOR FAN SUPPORT AND MAY NEED TO BE REPLACED. CONSULT A QUALIFIED ELECTRICIAN IF IN DOUBT.

Figures 1, 2, and 3 are examples of different ways to mount the outlet box.

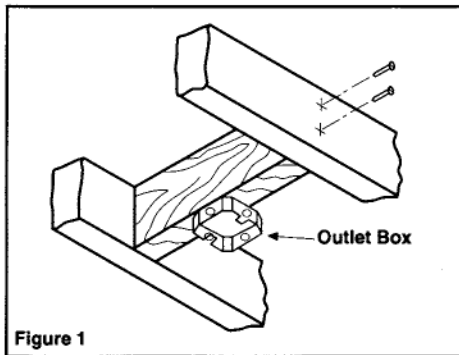

Figure 1

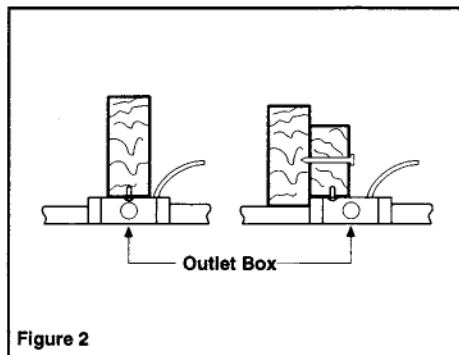

Figure 2

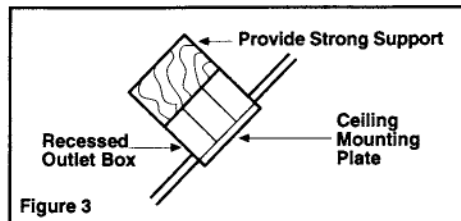

Figure 3

Note: You may need a longer down-rod to maintain proper blade clearance when installing on a steep, sloped ceiling. **The maximum angle allowable is 30°** If the canopy touches downrod, remove the decorative canopy bottom cover and turn the canopy 180° before attaching the canopy to the mounting plate.

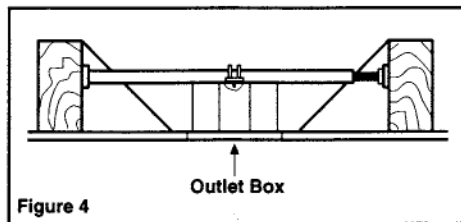

Figure 4

To hang your fan where there is an existing fixture but no ceiling joist, you may need an installation hanger bar as shown in Figure 4 (available at your Progress Lighting Retailer).

## 3. Installing Your Fan

# Hanging the Fan

**REMEMBER** to turn off the power. Follow the steps below to hang your fan properly.

**NOTE:** This ceiling fan is supplied with **two types of hanging assemblies**; the standard ceiling installation using the downrod with ball and socket mounting, and the “close-to-ceiling” mounting. The “close-to-ceiling” mounting is recommended in rooms with less than 8-foot ceilings or in areas where additional space is desired from the floor to the fan blades. When using standard downrod installation, the distance from the ceiling to the bottom of the fan blades will be approximately 12 inches. The “close-to-ceiling” installation reduces the distance from the ceiling to the bottom of the fan blades to approximately 9 inches.

Once you have decided which ceiling installation you will use, proceed with the following instructions. Where necessary, each section of the instructions will note the different procedures to follow for the two types of installation.

## OPTION 1: STANDARD CEILING MOUNTING

1. Remove the hanger bracket from the canopy by loosening the four screws on the top of the canopy. Remove the two non-slotted screws and loosen the slotted screws. This will enable you to remove the hanger bracket. (Figure 6)

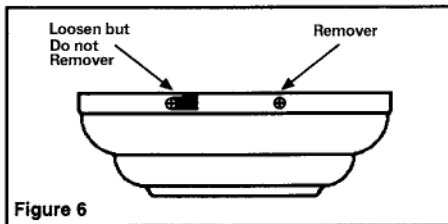

Figure 6

2. Remove the bolt and the clevis pin from the downrod assembly.
3. Route the wires exiting the top of the fan motor through the canopy, and then through the ball/downrod assembly and collar cover. (Figure 7)
4. Loosen, but do not remove, the 2 set screws on the collar on the top of the motor housing.
5. Align the holes at the bottom of the downrod with holes in the collar on top of the motor housing (Figure 7). Carefully insert the bolt through the holes in the collar and downrod. Be careful not to jam the bolt against the wiring inside the downrod. Insert clevis pin and bend to ensure security, as noted in the circle inset of Figure 7.
6. Tighten the two screws on the collar on the top of the motor housing (Fig. 7).

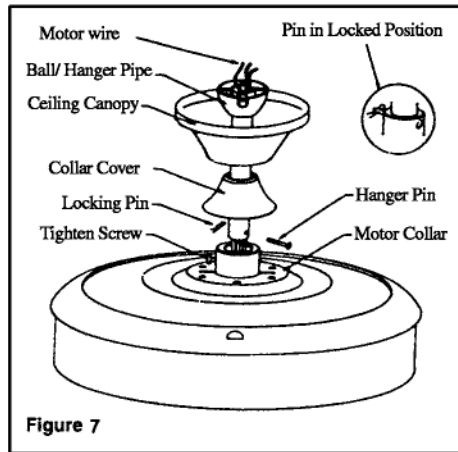

Figure 7

## OPTION 2: CLOSE-TO-CEILING MOUNTING

1. Remove the hanger bracket from the canopy by loosening the four screws on the top of the canopy. Remove the two non-slotted screws and loosen the slotted screws. This will enable you to remove the hanger bracket. (Figure 6)
2. Remove the decorative canopy bottom cover from the canopy by depressing the three studs. (Figure 8).

**WARNING**  
FAILURE TO PROPERLY INSTALL LOCKING PIN AS NOTED IN STEP 4 COULD RESULT IN FAN LOOSENING AND POSSIBLY FALLING.

- Remove three of the six screws and lock-washers (every other one) securing the motor collar to the top of the fan motor housing (Figure 9).
- Place the rubber gasket over the remaining three screws, route the wires exiting the top of the fan motor through the canopy (make sure the slot openings are on top) then proceed to place the ceiling canopy over the collar at the top of the motor (Figure 10).
- Align the mounting holes with the holes in the motor and fasten, using the three screws and lock-washers provided in the close-to-ceiling mount hardware packet. (Figure 10).

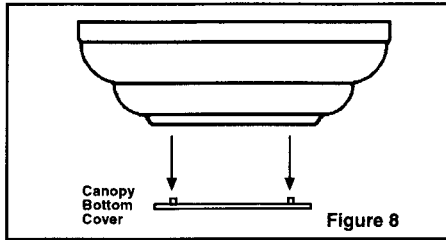

- Tighten the mounting screws securely.

**WARNING**

FAILURE TO COMPLETELY TIGHTEN THE THREE SCREWS IN STEP 6 COULD RESULT IN FAN LOOSENING AND POSSIBLY FALLING.

5.

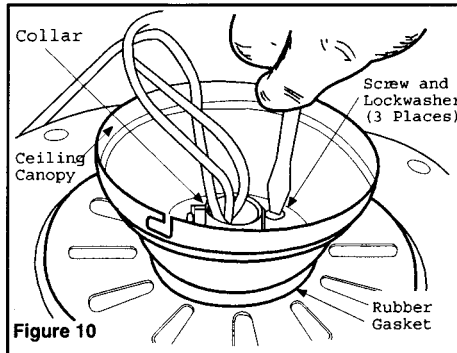
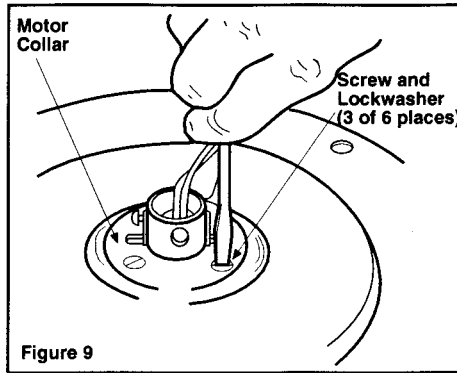

**WARNING**

TO REDUCE THE RISK OF FIRE, ELECTRIC SHOCK, OR OTHER PERSONAL INJURY, MOUNT FAN ONLY TO AN OUTLET BOX MARKED ACCEPTABLE FOR FAN SUPPORT AND USE THE MOUNTING SCREWS PROVIDED WITH THE OUTLET BOX.

## Installing Fan to the Electrical Box

- Pass the 120-volt supply wires through the center hole in the ceiling mounting plate as shown in Figure 11.
- Install the ceiling mounting plate on the electrical box by mounting screws provided with the outlet box. When using close-to-ceiling mounting, it is important that the mounting plate be level. If necessary, use leveling washers (not supplied) between the mounting plate and electrical box. Note that the flat side of the mounting plate is toward the electrical box (Figure 11).
- Securely tighten the two mounting screws.

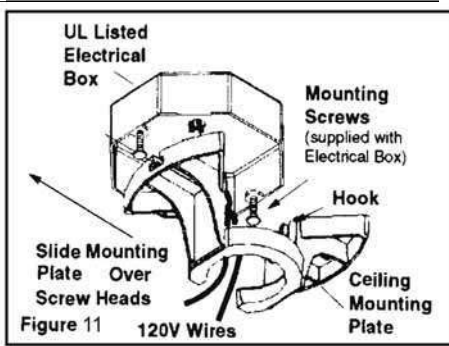

**WARNING**

THE HOOK AS SHOWN IN FIG. 12 IS ONLY TO BALANCE FAN WHILE ATTACHING WIRING. FAILURE TO HANG AS SHOWN IN FIG. 12 MAY RESULT IN HOOK BREAKING CAUSING THE FAN TO FALL. HOOK MUST PASS FROM INSIDE TO OUTSIDE OF CANOPY.

**WARNING**

WHEN USING THE STANDARD BALL/HANGER PIPE MOUNTING, THE TAB IN THE RING AT THE BOTTOM OF THE MOUNTING PLATE MUST REST IN THE GROOVE OF THE HANGER BALL. FAILURE TO PROPERLY SEAT THE TAB IN THE GROOVE COULD CAUSE DAMAGE TO WIRING.

4. Carefully lift the fan assembly up to the ceiling mounting plate. If using close-to ceiling mounting, hang the fan on the hook provided by utilizing one of the holes at the outer rim of the ceiling canopy (Figure 12). If using standard mounting, seat the hanger ball in the mounting plate socket. Make sure the tab on the mounting plate socket is properly seated in the groove in the hanger ball.

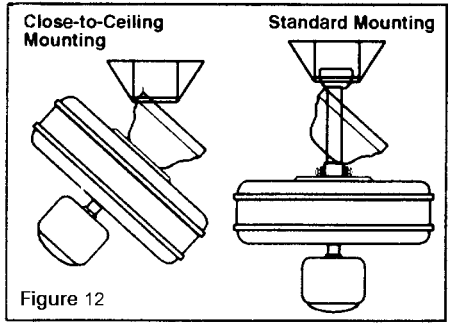

# Making the Electrical Connections

**REMEMBER** to disconnect the power. If you feel that you do not have enough electrical wiring knowledge or experience, have your fan installed by a licensed electrician.

Follow the steps below to connect the fan to your household wiring. Use the wire connecting nuts supplied with your fan. Secure the connectors with electrical tape. Make sure there are no loose strands or connections.

**Step 1** Connect the two green fan ground wires, located on the downrod and mounting plate, to the household ground wire. When using Close-to-Ceiling mounting, there is only one green ground wire from the ceiling mounting plate since the ball/downrod assembly is not used.

**Step 2** Connect the fan light supply (blue) wire and the fan supply (black) wire to the black household supply wire as shown in Figure 13.

**Step 3** Connect the neutral fan (white) wire to the white neutral household wire.

**Step 4** After connecting the wires, spread them apart so that the green and white wires are on one side of the outlet box and the black wire is on the other side.

**Step 5** Turn the wire connecting nuts upward and push the wiring into the outlet box.

## WARNING

TO REDUCE THE RISK OF FIRE OR ELECTRIC SHOCK, DO NOT USE A WALL MOUNTED SOLID STATE SPEED CONTROL WITH THIS FAN. IT WILL PERMANENTLY DAMAGE THE ELECTRONIC CIRCUITRY.

## WARNING

EACH WIRE NUT (WIRE CONNECTOR) SUPPLIED WITH THIS FAN IS DESIGNED TO ACCEPT UP TO ONE 12 GAUGE HOUSE WIRE AND TWO WIRES FROM THE FAN. IF YOU HAVE LARGER THAN 12 GAUGE HOUSE WIRING OR MORE THAN ONE HOUSE WIRE TO CONNECT TO THE FAN WIRING, CONSULT AN ELECTRICIAN FOR THE PROPER SIZE WIRE NUTS TO USE.

**WARNING**  
ELECTRICAL DIAGRAMS ARE FOR REFERENCE ONLY. OPTIONAL USE OF ANY LIGHT KIT SHALL BE UL LISTED AND MARKED SUITABLE FOR USE WITH THIS FAN.

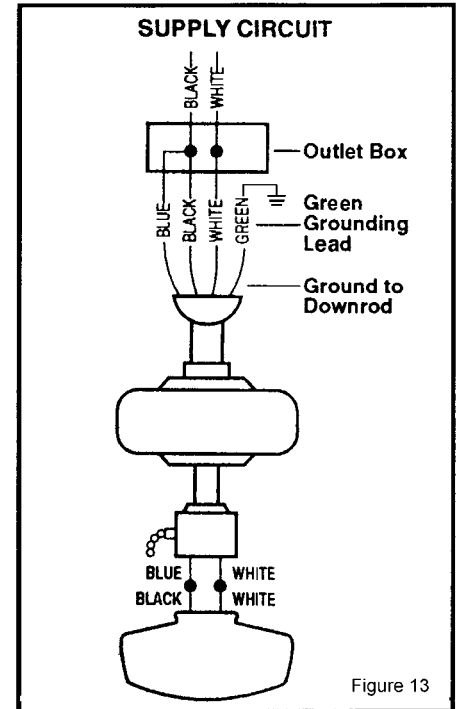

Figure 13

# Finishing the Fan Installation

## OPTION 1: STANDARD CEILING MOUNTING

1. Align the locking slots of the ceiling canopy with the two screws in the mounting plate. Push up to engage the slots and turn clockwise to lock in place. Immediately tighten the two mounting screws firmly.
2. Install the remaining two mounting screws into the holes in the canopy and tighten firmly.
3. You may now proceed to attaching the fan blades.

**WARNING**

**WHEN USING THE STANDARD BALL/DOWNROD MOUNTING, THE TAB IN THE RING AT THE BOTTOM OF THE MOUNTING PLATE MUST REST IN THE GROOVE OF THE HANGER BALL. FAILURE TO PROPERLY SEAT THE TAB IN THE GROOVE COULD CAUSE DAMAGE TO WIRING.**

**WARNING**

**LOCKING SLOTS OF CEILING CANOPY ARE PROVIDED ONLY AS AN AID TO MOUNTING. DO NOT LEAVE FAN ASSEMBLY UNATTENDED UNTIL ALL FOUR CANOPY SCREWS ARE ENGAGED AND FIRMLY TIGHTENED.**

## OPTION 2: CLOSE-TO-CEILING MOUNTING

1. Carefully unhook the fan from the mounting plate and align the locking slots of the ceiling canopy with the two screws in the mounting plate. Push up to engage the slots and turn clockwise to lock in place. Immediately tighten the two mounting screws firmly.

2. Install the remaining two mounting screws into the holes in the canopy and tighten firmly.
3. You may now proceed to attaching the fan blades.

# Attaching the Fan Blades

1. Attach blade to blade bracket using the screws as shown in Figure 14 . Please note that the rubber washers are pre-attached to the blade bracket. Start a screw into the bracket. Repeat for the two remaining screws.
2. Tighten each screw securely.
3. Fasten the blade assembly to the motor by inserting the alignment post into the slot on the bottom of the motor and tightening the motor screws. Please note that the motor screws are pre-attached into the blade brackets. (Figure 15)
4. Repeat steps 1, 2 & 3 for the remaining blades.

# Blade Balancing

All blades are grouped by weight. Because plastic injection blades vary in density, the fan may wobble even though the blades are weight matched. The following procedure should correct most fan wobble. Check after each step.

1. Check that all blade and blade bracket screws are secure.
2. Most fan wobble problems are caused when blade levels are unequal. Check this level by selecting a point on the ceiling above the tip of one of the blades. Measure from a point on the center of each blade to the point on the ceiling. Measure this distance as shown in Figure 16. Rotate the fan until the next blade is positioned for measurement. Repeat for each blade. Measurements deviation should be within 1/8". Run the fan for 10 minutes.

3. Make sure that canopy is tightened securely to ceiling mounting plate, and that the ceiling mounting plate is tightened securely to the electrical box.
4. Interchanging two adjacent blades can redistribute the weight and possibly result in smoother operation.
5. Use the enclosed Blade Balancing Kit if the blade wobble is still noticeable.

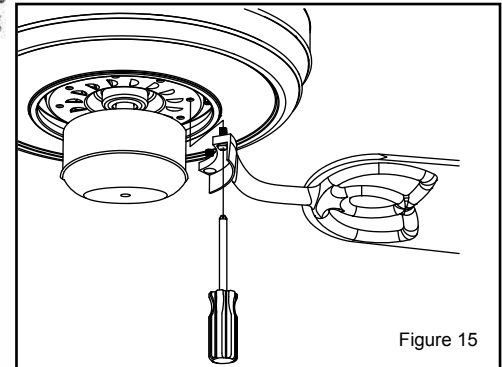
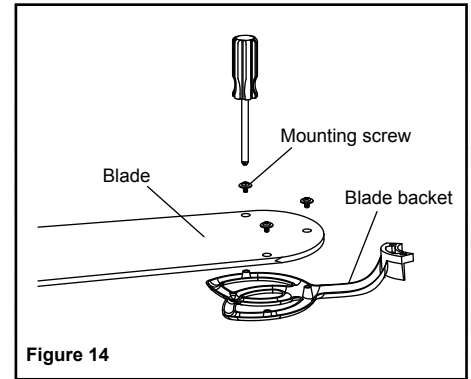

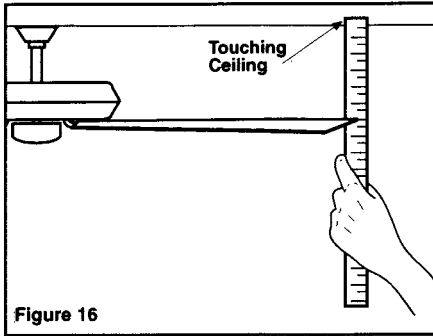

Turn on the power and check the operation of the fan. The pull chain controls the fan speed as follows: 1 pull - High, 2 pulls - Medium, 3 pulls - Low and 4 pulls - Off.

Speed settings for warm or cool weather depend on factors such as the room size, ceiling height, number of fans, and so on.

**Warm weather** – (Forward) A downward air flow creates a cooling effect as shown in Figure 17. This allows you to set your air conditioner on a higher setting without affecting your comfort.

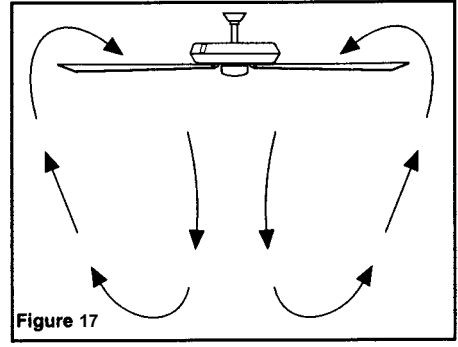

**NOTE**  
NOTE: WAIT FOR FAN TO STOP BEFORE REVERSING THE DIRECTION OF BLADE ROTATION.

**WARNING**  
TO REDUCE THE RISK OF PERSONAL INJURY, DO NOT BEND THE BLADE HOLDERS WHILE INSTALLING, BALANCING THE BLADES, OR CLEANING THE FAN. DO NOT INSERT FOREIGN OBJECTS BETWEEN ROTATING FAN BLADES.

**Cool weather** – (Reverse) An upward airflow moves warm air off the ceiling area as shown in Figure 18. This allows you to set your heating unit on a lower setting without affecting your comfort.

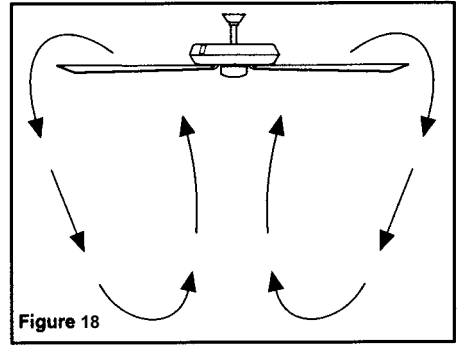

# 10. Operating Your Fan

FAN SIZE	SPEED	VOLTS	AMPS	WATTS	RPM	N.W.	G.W.
52"	Low	120	0.25	17	90	17.1 (7.8Kg)	19.1 (8.7Kg)
	Med.	120	0.36	35	130		
	High	120	0.46	56	180		

These are approximate measures. They do not include Amps and Wattage used by the light kit.

Here are some suggestions to help you maintain your fan.

1. Because of the fan's natural movement, some connections may become loose. **Check the support connections, brackets, and blade attachments twice a year.** Make sure they are secure. **(It is not necessary to remove fan from ceiling.)**

2. Clean your fan periodically to help maintain its new appearance over the years. Do not use water when cleaning. Use only a soft brush or lint-free cloth to avoid scratching the finish. The plating is sealed with a lacquer to minimize discoloration or tarnishing. This could damage the motor, or

the wood, or possibly cause an electrical shock.

3. You can apply a light coat of furniture polish to the wood for additional protection and enhanced beauty. Cover small scratches with a light application of shoe polish.

4. **There is no need to oil your fan.** The motor has permanently lubricated sealed ball bearings.

**WARNING**

**MAKE SURE THE POWER IS OFF AT THE ELECTRICAL PANEL BOX BEFORE YOU ATTEMPT ANY REPAIRS. REFER TO THE SECTION, "MAKING ELECTRICAL CONNECTIONS."**

© 2007 Progress Lighting, Inc.  
701 Millennium Blvd.,  
Greenville, SC 29607  
All Rights Reserved

## *11. Care of Your Fan/Specifications*

## **Problem**

## **Solution**

Fan will not start.

1. Check main and branch circuit fuses or breakers.
2. Check line wire connections to the fan and switch wire connections in the switch housing.  
**CAUTION:** Make sure main power is off.

Fan sounds noisy.

1. Make sure all motor housing screws are snug.
2. Make sure the screws that attach the fan blade bracket to the motor hub are tight.
3. Make sure wire nut connections are not rattling against each other or the interior wall of the switch housing.  
**CAUTION:** Make sure main power is off.
4. Allow a 24-hour “breaking-in” period. Most noises associated with a new fan disappear during this time.
5. If using the Ceiling Fan light kit, make sure the screws securing the glassware are tight. Check that the light bulb is also secure.
6. Make sure the canopy is a short distance from the ceiling.  
It should not touch the ceiling.
7. Make sure your ceiling box is secure and rubber isolator pads were used between the hanger bracket and ceiling box.

*Troubleshooting 12.*