

INSTALLATION INSTRUCTIONS FOR FOOT PEDAL ACTIVATED WATER CLOSET AND URINAL FLUSHOMETERS



**Royal 310
Exposed Model Shown**



**Crown Naval 313 INT'L
Concealed Model Shown**



**Royal, Regal, and
Crown Naval**
Models 310, 312, 313, 313 INT'L,
318, 320, 323 and 343

**Exposed and Concealed
Foot Pedal Activated
Closet and Urinal
Flushometer Valves**

Made in the U.S.A.

**Royal 313
Concealed Model Shown**



LIMITED WARRANTY

Sloan Valve Company warrants its Sloan Flushometers to be made of first class materials, free from defects of material or workmanship under normal use and to perform the service for which they are intended in a thoroughly reliable and efficient manner when properly installed and serviced, for a period of three years (1 year for special finishes) from date of purchase. During this period, Sloan Valve Company will, at its option, repair or replace any part or parts which prove to be thus defective if returned to Sloan Valve Company, at customer's cost, and this shall be the sole remedy available under this warranty. No claims will be allowed for labor, transportation or other incidental costs. This warranty extends only to persons or organizations who purchase Sloan Valve Company's products directly from Sloan Valve Company for purpose of resale.

THERE ARE NO WARRANTIES WHICH EXTEND BEYOND THE DESCRIPTION ON THE FACE HEREOF. IN NO EVENT IS SLOAN VALVE COMPANY RESPONSIBLE FOR ANY CONSEQUENTIAL DAMAGES OF ANY MEASURE WHATSOEVER.

PRIOR TO INSTALLATION

Before installing the Sloan Flushometer, be sure the items listed below are installed. Also, refer to the rough-in diagrams on Page 2.

- Closet/urinal fixture
- Drain line
- Water supply line
- Drill holes in wall for foot pedal actuator and water inlet to fixture

Due to code restrictions and installation practices, the Crown Naval 313 INT'L is for International use only.

Important:

- INSTALL ALL PLUMBING IN ACCORDANCE WITH APPLICABLE CODES AND REGULATIONS.
- WATER SUPPLY LINES MUST BE SIZED TO PROVIDE AN ADEQUATE VOLUME OF WATER FOR EACH FIXTURE.
- FLUSH ALL WATER LINES PRIOR TO MAKING CONNECTIONS.

Most Low Consumption water closets (1.6 gallon/6.0 liter) require a minimum flowing pressure of 25 psi (172 kPa).

The Sloan Flushometer is designed to operate with 15 to 100 psi (104 to 689

kPa) of water pressure. **THE MINIMUM PRESSURE REQUIRED TO THE VALVE IS DETERMINED BY THE TYPE OF FIXTURE SELECTED.** Consult fixture manufacturer for minimum pressure requirements.

Most Low Consumption water closets (1.6 gpf/6.0 Lpf) require a minimum flowing pressure of 25 psi (172 kPa).

Protect the Chrome or Special finish of this Flushometer — **DO NOT USE TOOTHED TOOLS TO INSTALL OR SERVICE THE VALVE.** Also, see "Care and Cleaning" section of this manual.

IMPORTANT: EXCEPT FOR CONTROL STOP INLET, DO NOT USE PIPE SEALANT OR PLUMBING GREASE ON ANY VALVE COMPONENT OR COUPLING!

TOOLS REQUIRED FOR INSTALLATION

- Straight blade screwdriver for stop adjustment (exposed models only)
- Sloan A-50 Super-Wrench™, Sloan A-109 Plier Wrench or smooth jawed spud wrench
- Hole saw for foot pedal actuator and water inlet to fixture
- 1/16" hex wrench for supply flange (exposed models only)

WATER CLOSET ROUGH-IN

Model 310 — Water Saver (3.5 gpf/13.2 Lpf)
Model 310-1.6 Low Consumption (1.6 gpf/6.0 Lpf)

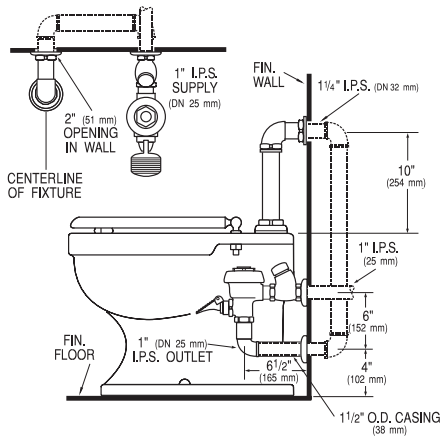

Model 313 — Water Saver (3.5 gpf/13.2 Lpf)
Model 313-1.6 Low Consumption (1.6 gpf/6.0 Lpf)

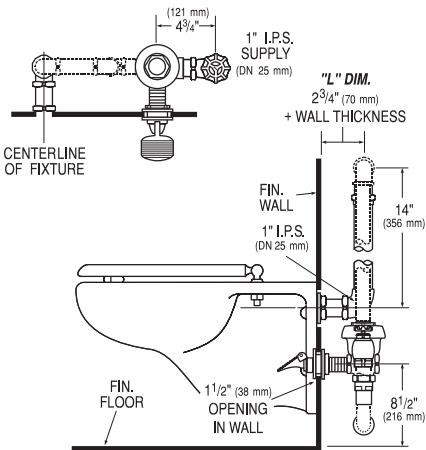

Model 312 — Water Saver (3.5 gpf/13.2 Lpf)
Model 312-1.6 Low Consumption (1.6 gpf/6.0 Lpf)

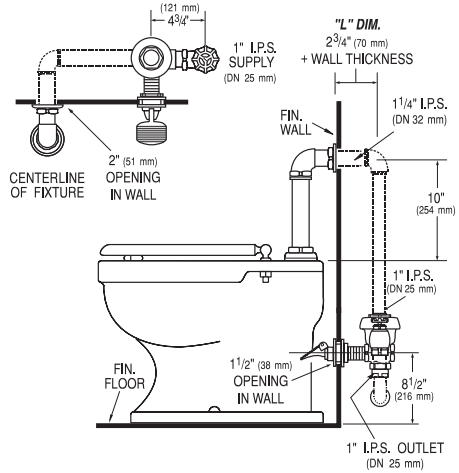

Model 318 — Water Saver (3.5 gpf/13.2 Lpf)
Model 318-1.6 Low Consumption (1.6 gpf/6.0 Lpf)

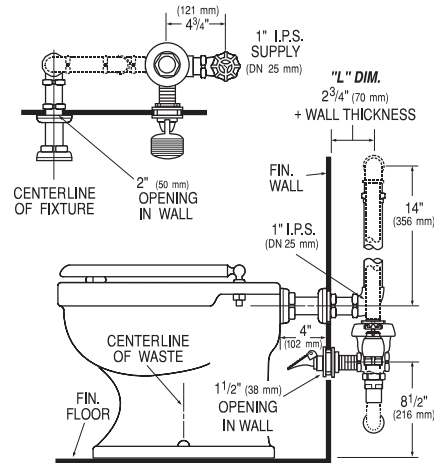

Note: Flush Connections shown in dotted lines not included

URINAL ROUGH-IN

Model 320 — Water Saver (1.5 gpf/5.7 Lpf)
Model 320-1.0 Low Consumption (1.0 gpf/3.8 Lpf)

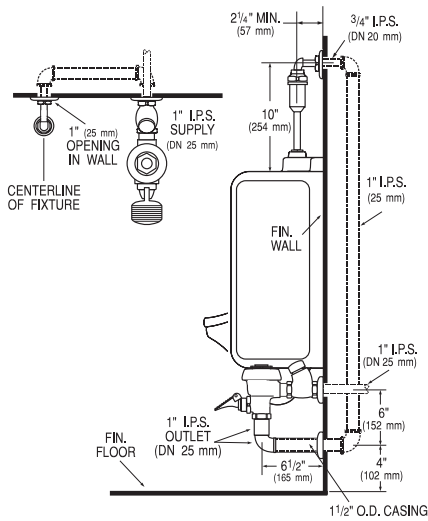

Model 323 — Water Saver (1.5 gpf/5.7 Lpf)
Model 323-1.0 Low Consumption (1.0 gpf/3.8 Lpf)

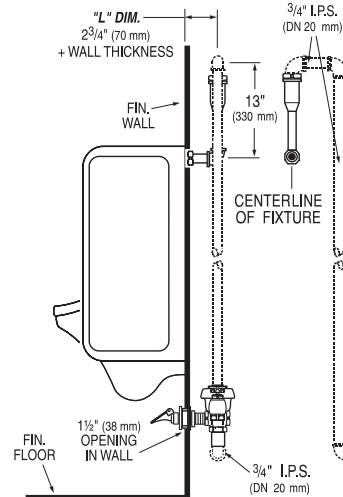

Model 343 — Water Saver (1.5 gpf/5.7 Lpf)
Model 343-1.0 Low Consumption (1.0 gpf/3.8 Lpf)

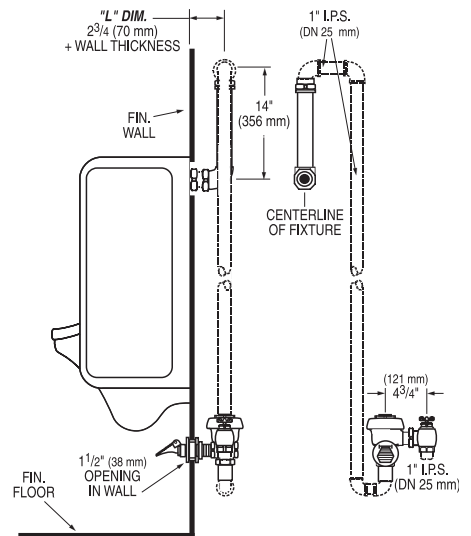

Note: Flush Connections shown in dotted lines not included

!!! IMPORTANT !!!

With the exception of Control Stop Inlet, DO NOT use pipe sealant or plumbing grease on any valve component or coupling!

!!! IMPORTANT !!!

Never open Control Stop to where the flow from the valve exceeds the flow capability of the fixture. In the event of a valve failure, the fixture must be able to accommodate a continuous flow from the valve.

!!! IMPORTANT !!!

Protect the chrome or special finish of Sloan Flushometers — DO NOT USE toothed tools to install or service these valves. Use a Sloan A-50 Super-Wrench™, Sloan A-109 Plier Wrench or smooth jawed spud wrench to secure all couplings. Also see “Care and Cleaning” section of this manual.

!!! IMPORTANT !!!

This product contains mechanical and/or electrical components that are subject to normal wear. These components should be checked on a regular basis and replaced as needed to maintain the valve's performance.

If you have questions about how to install your Sloan Flushometer, consult your local Sloan Representative or call Sloan Installation Engineering Department at:

1-888-SLOAN-14 (1-888-756-2614) OR 1-847-233-2016

1 Install Optional Sweat Solder Adapter (only if your supply pipe does not have a male thread)

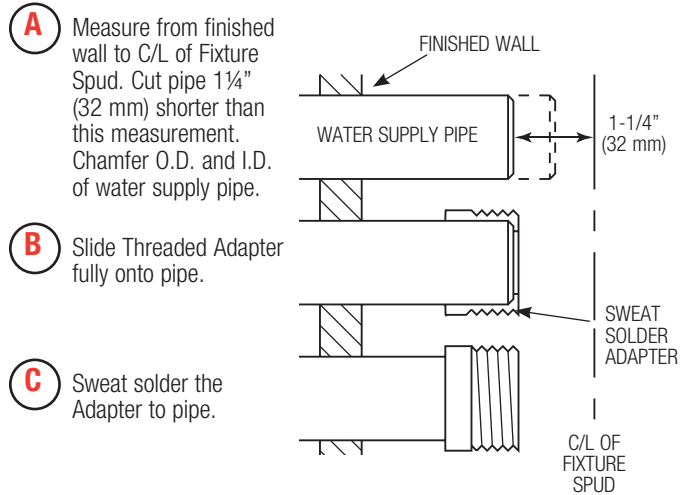

2 Install Cover Tube and Wall Flange to supply pipe

A Measure from finished wall to first thread of Adapter or threaded supply pipe (dimension "X"). Cut Cover Tube to this length.

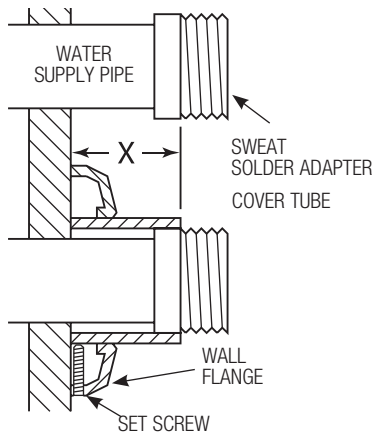

B Slide Cover Tube over pipe. Slide Wall Flange over Cover Tube until against wall.

3 Install Control Stop

A Thread Control Stop onto supply pipe. Tighten with a wrench until outlet is positioned as required.

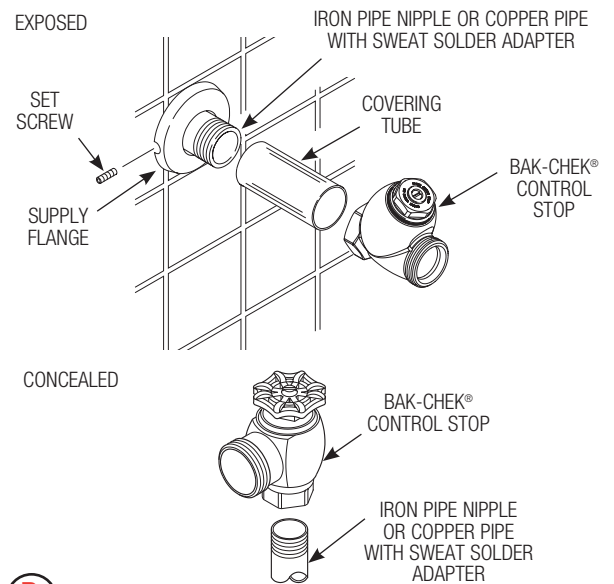

B Tighten Set Screw with a 1/16" hex wrench. For Exposed Flushometers — DO NOT install Vandal Resistant Stop Cap at this time.

4 Install Flushometer

A Lubricate tailpiece O-ring with water. Insert Adjustable Tailpiece into Control Stop. Tighten Tailpiece Coupling by hand.

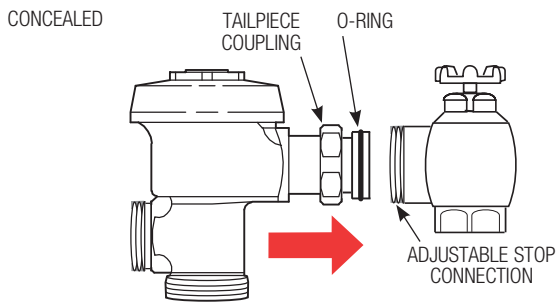
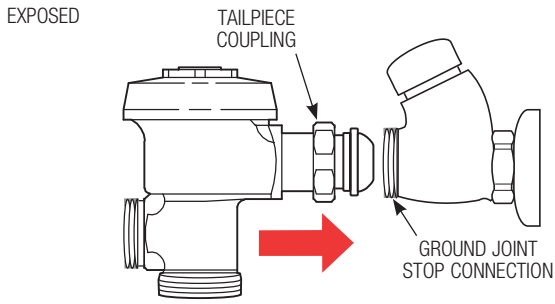

MODELS

MODEL 310/312

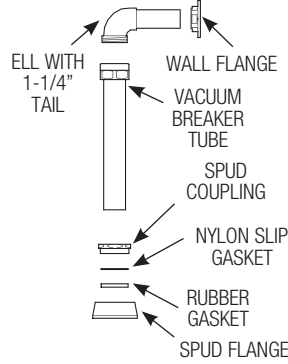

MODEL 313

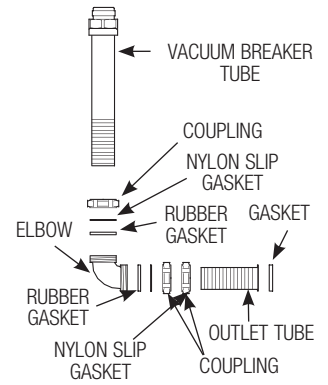

MODEL 313 INT'L

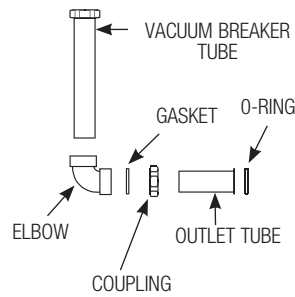

MODEL 318

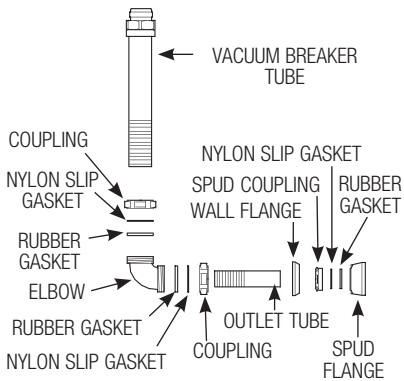

MODEL 320

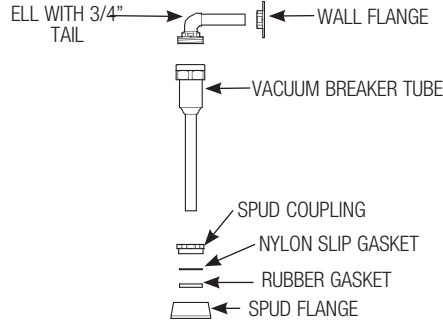

MODEL 323

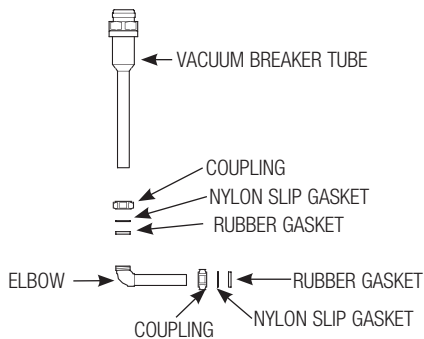

MODEL 343

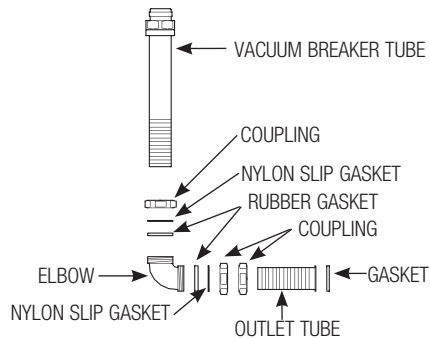

B Install remaining flush connection (supplied by installer) between Vacuum Breaker and Flushometer Valve as illustrated in the appropriate rough-in diagram on Page 2.

5 Install Vacuum Breaker & Flush Connection

!!! IMPORTANT !!!

DUE TO THE HIGH BACK PRESSURES THAT CAN BE CREATED BY STAINLESS WATER CLOSETS AND COMBINATION FIXTURES, THE FOLLOWING PROCEDURES MUST BE FOLLOWED WHEN INSTALLING THE FLUSH CONNECTION. FAILURE TO FOLLOW THESE PROCEDURES CAN RESULT IN SEPARATIONS. FOR SECURE CONNECTIONS IN HIGHER PRESSURE AND OTHER SEVERE CONDITION APPLICATIONS, THE FLUSH CONNECTIONS CAN BE SWEAT SOLDERED. REMOVE ALL PLASTIC AND RUBBER GASKETS BEFORE BEGINNING SOLDERING PROCESS.

When cutting Vacuum breaker and F-100/F-102 Flush Connection tubes to fit, always keep at least 1 1/4" (32 mm) of scoring to assure proper engagement with compression coupling (see Figure 2).

A

Install Flush Connection (Figure 1)

A 1 1/2" pipe connection (NOT supplied by Sloan) must be used to connect the fixture inlet from the wall to the flush connection. Secure flanged end of the F-100/F-102 Flush Connection to the 1 1/2" pipe using a 1 1/2" F-2-A Coupling with S-21 Gasket and Coupling nut. Tighten securely.

Items shown by dashed lines are not supplied by Sloan

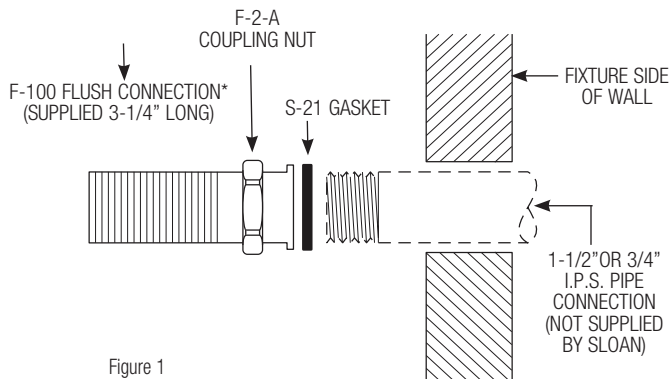

Figure 1

B

Install Slip Elbow (Figure 2)

Connect scored ends of vacuum breaker tube and F-100/F-102 flush connection to the elbow using coupling, slip gasket and rubber compression gasket. After applying Loctite® to scored ends, tighten securely.

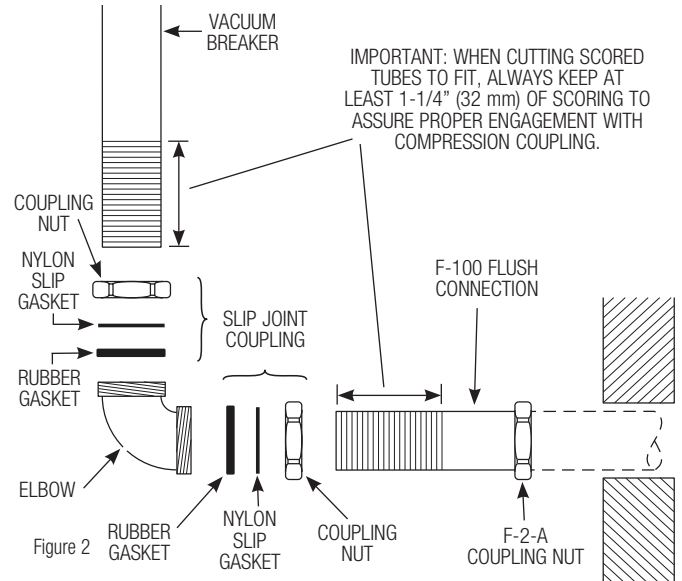

Figure 2

!!! IMPORTANT !!!

IMPORTANT: BEFORE INSERTING THE SCORED ENDS INTO THE ELBOW, APPLY SEVERAL DROPS OF LOCTITE (SUPPLIED BY SLOAN) TO THE SCORED ENDS OF THE TUBES (FIGURE 3). THIS SEALANT HELPS PREVENT SEPARATION UNDER HIGH-PRESSURE CONDITIONS. DO NOT USE ANY OTHER PIPE SEALANT OR LUBRICANT ON THIS CONNECTION.

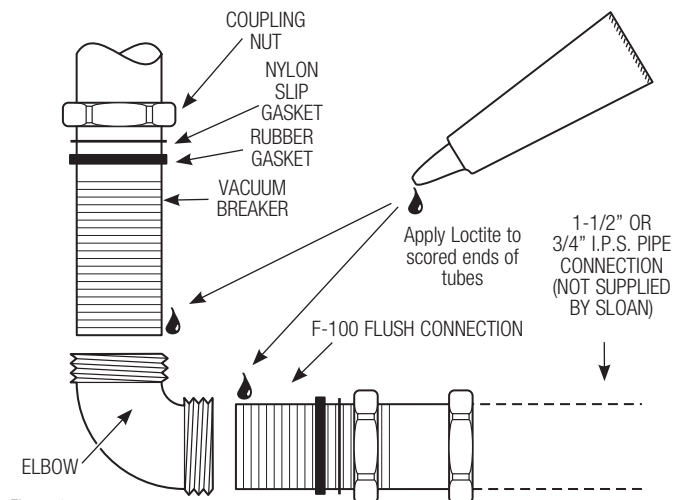
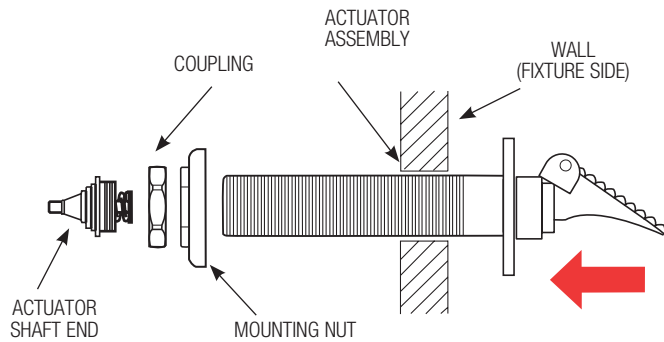

Figure 3

Loctite can also be used to secure Push Button Flange. See Sealant package for details.

6 Mount Foot Pedal Actuator Assembly to Wall (Concealed Models)

- A** Remove Actuator Shaft End, Coupling and Mounting Nut from Actuator Assembly.
- B** Insert Actuator Shaft through the 1½" (38 mm) wall opening from fixture side of wall.



- C** Install Mounting Nut, Coupling and Actuator Shaft End to Actuator Assembly. Hand tighten Mounting Nut to wall.
- D** Securely tighten Actuator Shaft End to Actuator Assembly.

7 Connect Foot Pedal Actuator Assembly to Flushometer

- A** Install Gasket between the Actuator Assembly and opening in Flushometer.

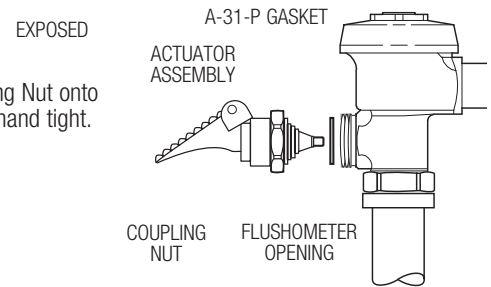

- B** Install Coupling Nut onto Flushometer hand tight.

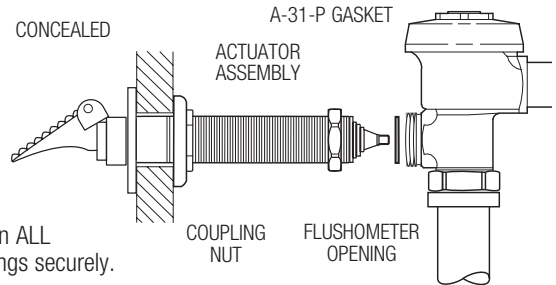

- C** Tighten ALL couplings securely.

Important Note: Use a Sloan A-50 "Super-Wrench™", A-109 Plier Wrench or smooth jawed spud wrench to secure all couplings. This will eliminate damage to chrome or special finish that normally occurs when slip-joint pliers, pipe wrenches or other "toothed" tools are used.

- D** Tighten Actuator Mounting Nut securely against wall (exposed model).

8 Flush Out Supply Line

- A** Make sure Control Stop is CLOSED and remove Flushometer Outer Cover.

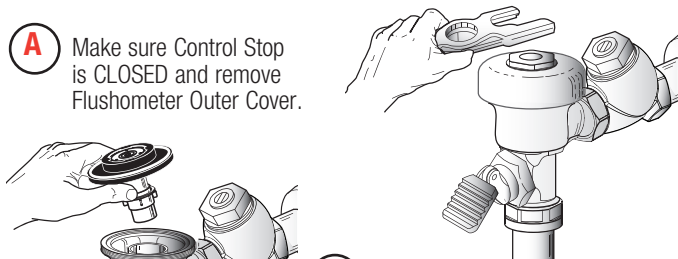

- B** Remove Inside Cover and lift out Inside Parts Assembly.

- C** Reinstall Outside and Inside Cover wrench tight. Open Control Stop to flush supply line. Close Control Stop and remove Outside and Inside Cover.

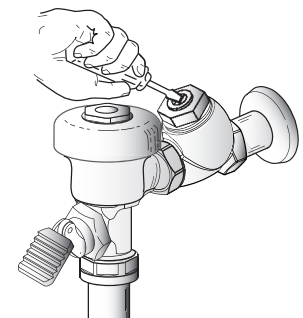
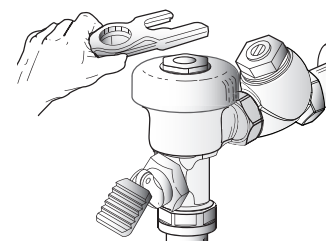

- D** Reinstall Inside Parts Assembly, Inside Cover and Outside Cover wrench tight.

9 Adjust Control Stop and Install Stop Cap

- A** Open Control Stop COUNTERCLOCKWISE one FULL turn from closed position.

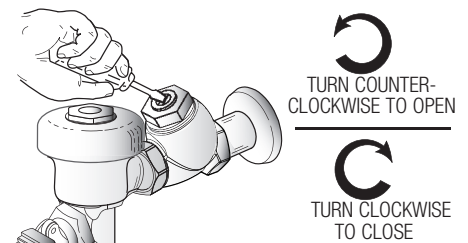

- B** Activate Flushometer.

- C** Adjust Control Stop after each flush until the rate of flow delivered properly cleanses the fixture.

!!! IMPORTANT !!!

Sloan Flushometers are engineered for quiet operation. Excessive water flow creates noise, while too little water flow may not satisfy the needs of the fixture. Proper adjustment is made when plumbing fixture is cleaned after each flush without splashing water out from the lip AND a quiet flushing cycle is achieved.

Never open Control Stop to where the flow from the valve exceeds the flow capability of the fixture. In the event of a valve failure, the fixture must be able to accommodate a continuous flow from the valve.

- D** Install Control Stop Cap onto Control Stop.

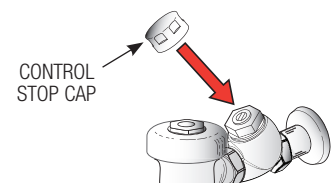

Care and Cleaning

DO NOT use abrasive or chemical cleaners (including chlorine bleach) to clean Flushometers as they may dull the luster and attack the chrome or special decorative finishes. Use ONLY soap and water, then wipe dry with clean cloth or towel.

While cleaning the bathroom tile, the Flushometer should be protected from any splattering of cleaner. Acids and cleaning fluids can discolor or remove chrome plating.

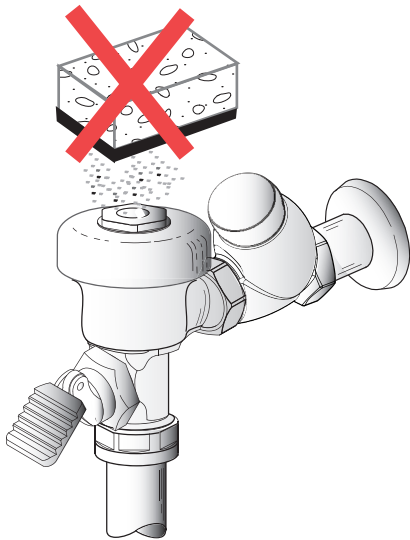

When assistance is required, please contact Sloan Valve Company Installation Engineering Department at:

1-888-SLOAN-14 (1-888-756-2614)

OR

1-847-233-2016

TROUBLESHOOTING GUIDE

1. Valve does not function (no flush).

- Control Stop or Main Valve is Closed. Open Control Stop or Main Valve.
- Foot Pedal Assembly is worn or damaged. Install Foot Pedal Repair Kit or replace Foot Pedal Assembly.
- Relief Valve is worn or damaged. Replace Inside Parts Kit.

2. Volume of water is not sufficient to siphon fixture.

- Control Stop is not open wide enough. Adjust Control Stop for desired delivery of water volume.
- Urinal Flushometer Parts inside a Closet Flushometer. Replace Inside Urinal Parts with proper Closet Flushometer Parts.
- Low Consumption Flushometer installed on a higher Consumption fixture. Replace Inside Parts Kit with Water Saver Kit.
- Water Saver Kit installed in old non-Water Saver bowl. Position Refill Head so that SIDE 1 is in the UP position (Regal Flushometers only). For other models, refer to Factory.
- Water supply volume or pressure is inadequate. If no gauges are available to properly measure supply pressure or volume of water at the Flushometer, then remove the Relief Valve from the Inside Parts Kit, reassemble the Flushometer and completely open the Control Stop.
 - If the fixture siphons, more water volume is required. If a 3.5 gpf Inside Parts Kit is installed in the Flushometer, then first flip the Refill Head (under the diaphragm) to obtain a 4.5 gpf volume. If this volume is still inadequate, remove the Flow Ring from the Guide to obtain a 6.5 gpf Kit. If additional flow is required, try a Low Pressure Guide Kit. **IMPORTANT** — Laws and Regulations requiring Low Consumption Fixtures (1.6 gpf/6.0 Lpf Water Closets and 1.0 gpf/3.8 Lpf Urinals) prohibit the use of higher flushing volumes.
 - If the fixture does not siphon or if a Low Consumption fixture is installed, or if the above steps do not prove satisfactory, steps must be taken to increase the water supply pressure and/or volume. Contact the fixture manufacturer for minimum water supply requirements of the fixture.

3. Flushometer closes off immediately.

- Ruptured or damaged Diaphragm. Replace Inside Parts Kit.
- Enlarged By-pass orifice from corrosion or damage. Replace Inside Parts Kit.

4. Length of flush is too short (short flush).

- Diaphragm Assembly and Guide Assembly are not hand-tight. Screw the two assemblies hand-tight.
- Enlarged By-pass orifice from corrosion or damage. Replace Inside Parts Kit.
- Urinal Flushometer Parts inside a Closet Flushometer. Replace Inside Urinal Parts with proper Closet Flushometer Parts.
- Low Consumption Flushometer installed on a higher Consumption fixture. Replace Inside Parts Kit with Water Saver Kit.
- Foot Pedal Assembly is damaged. Replace Foot Pedal Assembly.

5. Length of flush is too long (long flush) or continuous.

- Relief Valve is not seating properly or By-pass orifice is clogged because of foreign material, or By-pass orifice is closed by an invisible gelatinous film from "over-treated" water. Disassemble the working parts and wash thoroughly. **NOTE:** Size of the orifice in the by-pass is of utmost importance for the proper metering of water into the upper chamber of the flushometer. Do not enlarge or damage this orifice. Replace inside kit if cleaning does not correct problem.
- Supply line water pressure has dropped and is not sufficient to close the valve. Close Control Stop until pressure is restored.
- Closet Flushometer Parts inside a Urinal Flushometer. Replace Inside Closet Parts with proper Urinal Flushometer Parts.
- Inside Cover is damaged. Replace Inside Cover.

6. Chattering noise is heard during flush.

- The Segment Diaphragm is installed upside-down. Replace the Segment Diaphragm to the proper position as instructed by markings on the Diaphragm.
- Inside Cover is damaged. Replace Inside Cover.

7. Foot Pedal Leaks.

- Foot Pedal Gasket, Seal or Assembly is damaged. Replace as required.