

NOTES: UNLESS OTHERWISE SPECIFIED

1. FOR GENERAL SERIES SPECIFICATIONS, SEE SD74-0000.
2. MATERIAL SPECIFICATIONS: BRASS PER ASTM B16
3. FINISH SPECIFICATIONS: .000030" MIN. GOLD PER ASTM B488 OVER .000050 MIN NICKEL PER AMS QQ-N-290
4. ELECTRICAL SPECIFICATIONS:
CURRENT RATING: 8 AMPS
CONTACT RESISTANCE: 1.0 MILLIOHM MAX
5. FOR USE WITH 20 AWG OR EQUIVALENT
6. REFER TO CAP10-01 FOR CABLE ASSEMBLY PROCEDURE

REV	DESCRIPTION	BY DATE	APPD
C	REVISED PER ER7306	04/1/08 CMB	CMB

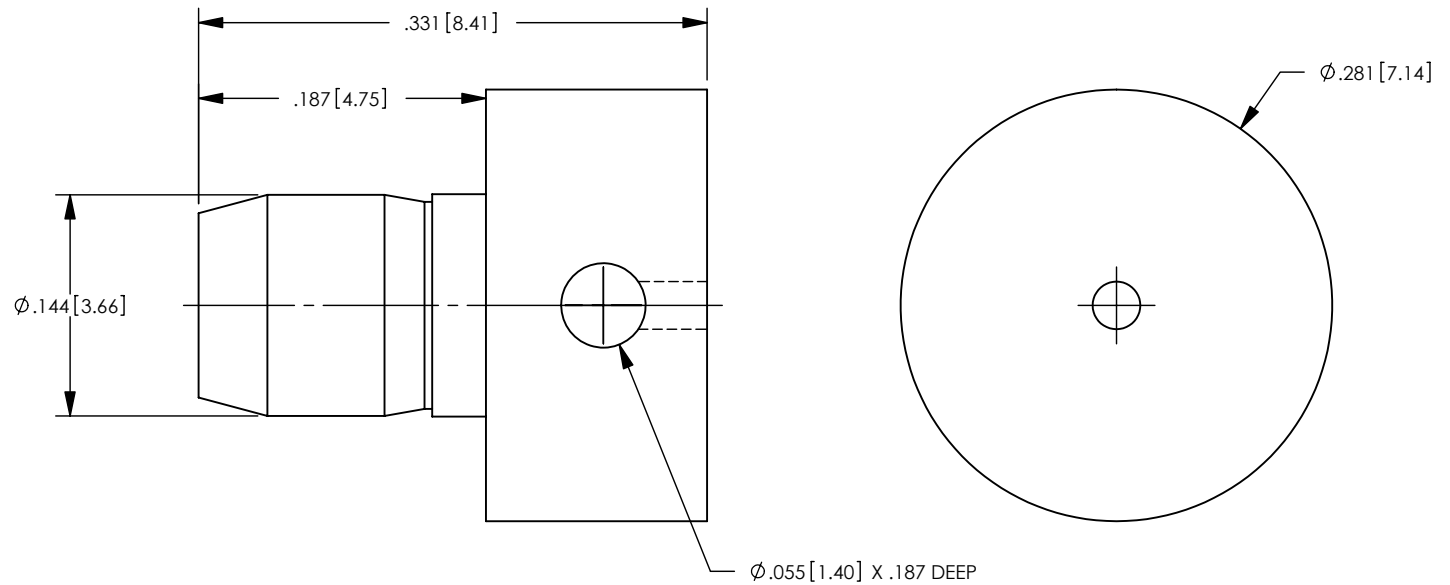

CATALOG P/N: 01414

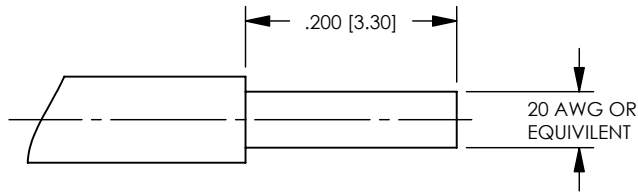

RECOMMENDED CABLE TRIM DIMENSIONS

PER ASME Y14.5M-1994 UNLESS OTHERWISE SPECIFIED: DIMENSIONS ARE IN INCHES [MM] TOLERANCES: DECIMAL: .XX [X.X] ± .01 [0.3] .XXX [X.XX] ± .005 [0.13] .XXXX [X.XXX] ± .XXXX ANGLES: ± 2° SCALE: 8:1				 Winchester Electronics Corporation 62 Barnes Industrial Road North Wallingford, Connecticut 06492	
CUSTOMER DRAWING			 POWERSNAP, RIGHT ANGLE SOLDER MOUNT 20 AWG, 8 AMP		
DRAWN LMD	DATE 7/17/06	APPROVED J.CAVANAUGH	DATE 8/2/06	A	SD01414
APPROVED T.CALVER	DATE 8/2/06	APPROVED XXX	DATE XX/XX/XX		
				SHT 1 OF 1	REV C