

INSTRUCTION MANUAL



Velvet Upholstered Desk Chair

V1.0

! NOTICE

- Highly recommend immediate clean of the upholstery fabric.
- Clean the chair with lukewarm water, mild detergent & soft cloth.
- Please do not exceed the weight limitation of this item. Do not stand on as a step ladder.
- Firmly secure all bolts before use. Reconfirm all bolts are secure every 90 days.
- Please adjust the speed slowly when you use electric drill for assembling to avoid screw slippage.
- Do not use or store this item in the proximity of open flame or flammable/combustible chemicals.

TOOLS REQUIRED



**250 LBS
CAPACITY**



**2 PERSON
ASSEMBLY**



**UP TO 20 MIN.
ASSEMBLY**

HARDWARE

1

BOLT
M6 x 18mm



4 PCS

2

**ALLEN
WRENCH**
M4

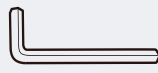

1 PCS

PARTS

A

SEAT

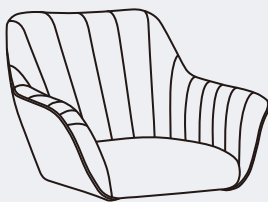

1 PC

B

SEAT PLATE

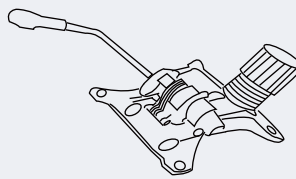

1 PC

C

GAS LIFT GOLDEN

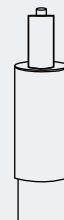

1 PC

A

BASE GOLDEN

Golden cover
already attached

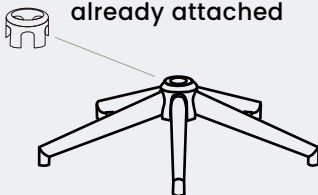

1 PC

B

CASTOR GOLDEN



1 PC

PRODUCT ASSEMBLY - OVERALL VIEW

Look at following overall view of this chair and learn the exact position of each parts to be assembled.

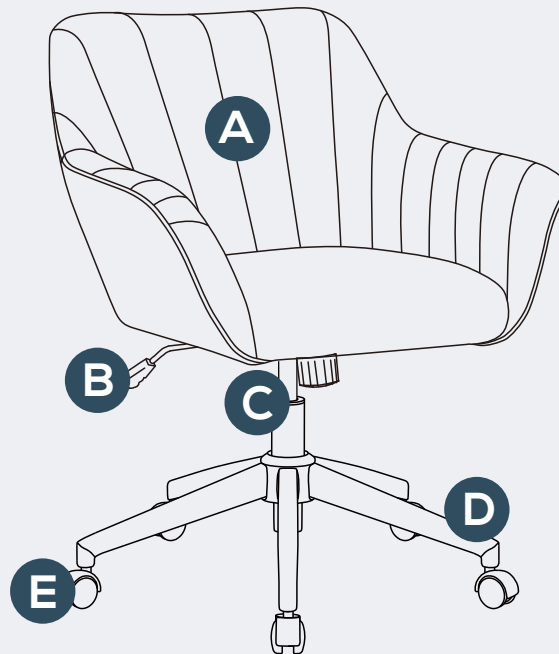

PRODUCT ASSEMBLY

1

1. Insert 5 pcs of **Part E Castor** to **Part D Base**.
Attention: Push the castors fully into the holes.

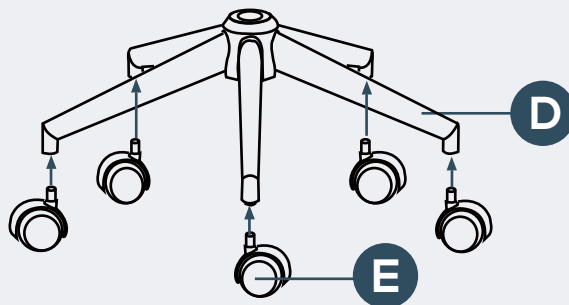

2

2. Insert **Part C Gas Lift** to **Part D Base**.

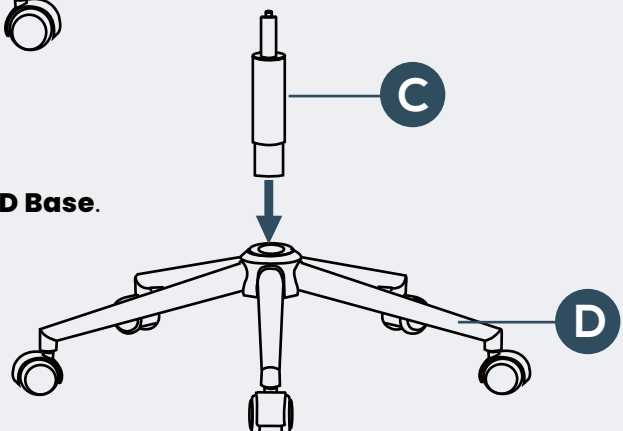

PRODUCT ASSEMBLY

3

Place **Part A Seat** upsidedown on flat floor.

Attach **Part B Seat Plate** on the seat as below with 4pcs of **Hardware #1 Bolt**.

Attention: Place the plastic cap end toward front of the seat as below.

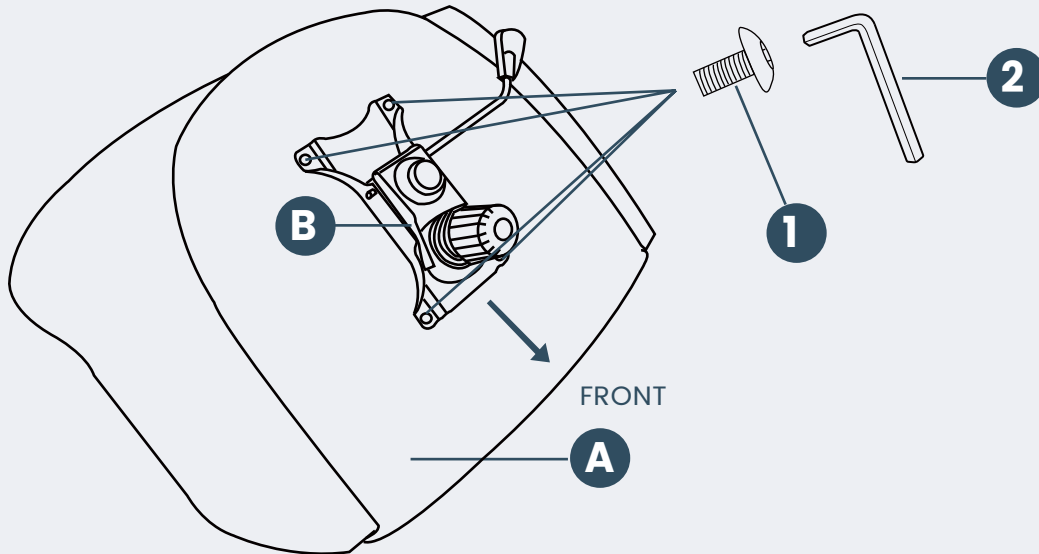

4

Put the assembled seat directly on top of **Part C Gas Lift** as below.

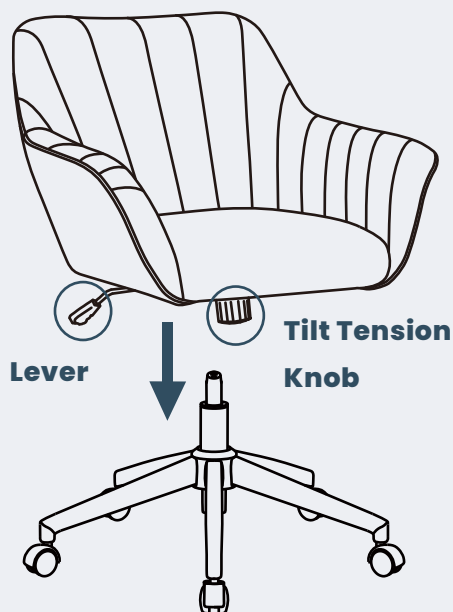

SEAT HEIGHT ADJUSTABLE

Simply push the Lever to adjust and fit into a range of desk heights.

TILT BACK FUNCTION

Adjust the tilt tension knob to control how much force you need to tilt.

LOCK FUNCTION

Pull the lever outward to open lock for tilting. Lock in place to prevent tilting, please push the lever inward.