



JOHN DEERE

OPERATOR'S MANUAL

Spike Aerator
40"

SAT-400JD
1019511-A
04 / 07 / 2021
English

Introduction

Using Your Operator's Manual

Read this entire operator's manual, especially the safety information, before operating.

This manual is an important part of your machine. Keep all manuals in a convenient location so they can be accessed easily.

Use the safety and operating information in the attachment operator's manual, along with machine operator's manual, to operate and service the attachment safely and correctly.

If your attachment manual has a section called Preparing the Machine, it means that you will have to do something to your tractor or vehicle before you can install the attachment. The Assembly and Installation sections of this manual provide information to assemble and install the attachment to your tractor or vehicle. Use the Service section to make any needed adjustments and routine service to your attachment.

If you have any questions or concerns with the assembly, installation, or operation of this attachment, see your local John Deere dealer.

Warranty information on this John Deere attachment can be found in the warranty statement included in this manual.

SAT-400JD

Product Compatibility

Compatible with Lawn and Garden Tractors

Table of Contents

Introduction	2
Safety Labels	3
Safety	4 - 6
Specifications	6
Parts / Assembly	7 - 11
Installing / Removing	12
Operation	13 - 14
Maintenance	15
Service	15
Storage	16
Quality / Warranty	17 - 18

Record Product Information

In the event that you need to contact an Authorized Service Center for information on servicing your product, record the following information in the spaces provided below.

DATE OF PURCHASE:

DEALER NAME:

DEALER PHONE:

Original instructions. All information, illustrations and specifications in this manual are based on the latest information available at the time of publication. The right is reserved to make changes at any time without notice.

Safety Labels

Understanding The Machine Safety Labels

The machine safety labels shown in this section are placed in important areas on your machine to draw attention to potential safety hazards.

On your machine safety labels, the words **DANGER**, **WARNING**, and **CAUTION** are used with this safety-alert symbol. **DANGER** identifies the most serious hazards.

The operator's manual also explains any potential safety hazards whenever necessary in special safety messages that are identified with the word, **CAUTION**, and the safety-alert symbol.

French or Spanish Safety Labels



Safety labels with content in French or Spanish are available for this machine through authorized John Deere dealers. See your John Deere dealer.

Warning

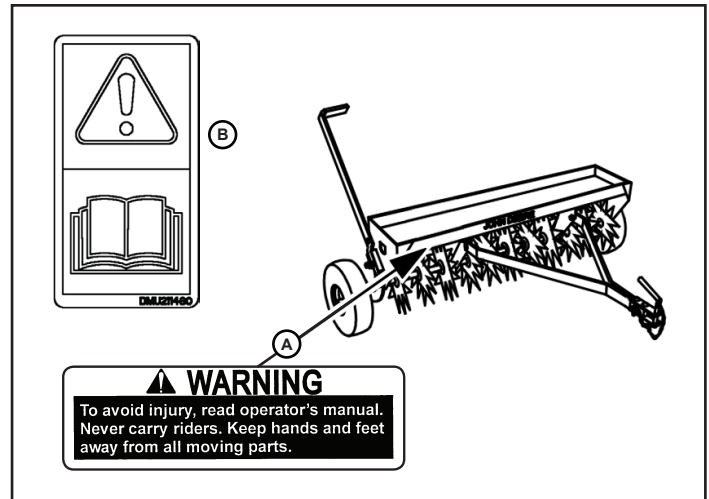

A - Warning - M133767



To avoid injury, read operator's manual. Never carry riders. Keep hands and feet away from all moving parts.

B - Warning - DMU211480

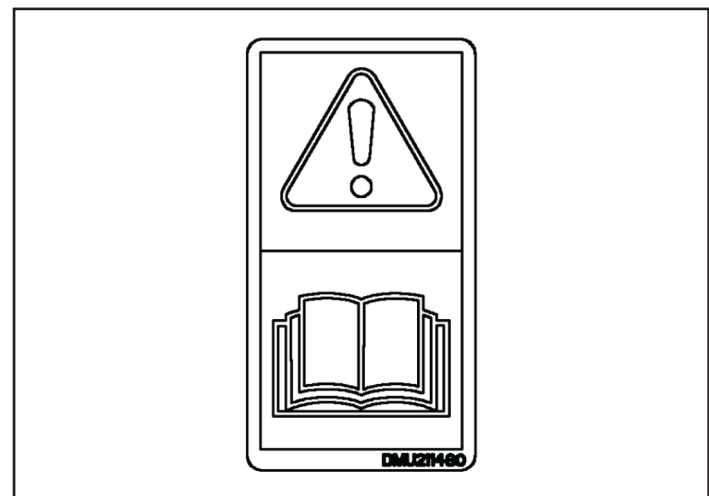

This operator's manual contains important information necessary for safe machine operation. Observe all safety rules to avoid accidents.

Safety

Read the general safety operating precautions in your machine operator's manual for additional safety information.

Operate Safely

- Know your controls and how to stop quickly. Read your machine Operator's Manual.
- Keep hands and feet away from all moving parts.
- To avoid possible personal injury and/or equipment damage, never exceed the recommended operating speed range of 5 to 8 km/hr (3 to 5 mph).
- DO NOT attempt to disconnect attachment from tractor with weight remaining in the attachment.
- The Aerator Tines have extremely sharp points. Wear gloves and handle with care.
- Store attachment with tines against wall or floor to avoid accidental contact.
- Watch out for traffic when crossing or near roadways.
- Only tow your attachment behind machines for which it was designed. See your John Deere dealer for product information.
- Check vehicle brake action before you operate. Adjust or service brakes as necessary.
- Inspect machine and attachment before you operate. Be sure hardware is tight. Repair or replace damaged, badly worn, or missing parts. Be sure guards and shields are in good condition and fastened in place. Make any necessary adjustments before you operate.
- Clear work area of objects that might be thrown or struck. Keep people and pets out of the work area. Stop machine if anyone enters the area.
- If you hit an object, stop and inspect machine and attachment. Make repairs before you operate. Keep machine and attachment properly maintained and in good working order.
- DO NOT leave machine unattended when it is running.
- Only operate during daylight or with good artificial light.
- Do not wear radio or music headphones while operating the machine. Safe operation requires your full attention.

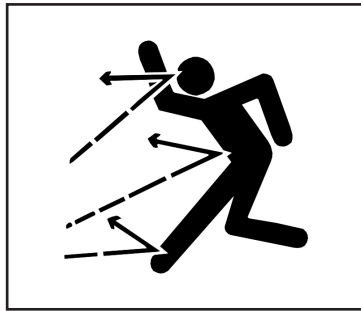

- Do not let anyone, especially children, ride on machine or attachment. Riders are subject to injury such as being struck by foreign objects and being thrown off. Riders may also obstruct the operator's view, resulting in the machine being operated in an unsafe manner.
- This attachment is intended for use in lawn care and home applications. Do not tow behind a vehicle on a highway or in any high speed application.
- Check machine brake action before you operate. Adjust or service brakes as necessary.
- Do not operate machine at high speeds when you tow. Travel slowly over rough ground.
- Keep all parts in good condition and properly installed. Fix damage immediately. Replace worn or broken parts. Replace all worn or damaged safety and instruction decals.
- Do not modify machine or safety devices. Unauthorized modifications to the machine or attachment may impair its function and safety.

Towing Loads Safely

- Stopping distance increases with speed and weight of towed load. Travel slowly and allow extra time and distance to stop.
- Total towed weight must not exceed limits specified in towing vehicle operator's manual.
- Excessive towed load can cause loss of traction and loss of control on slopes. Reduce towed weight when operating on slopes.
- Never allow children or others in or on towed equipment.
- Use only approved hitches. Tow only with a machine that has a hitch designed for towing. Do not attach towed equipment except at the approved hitch point.
- Follow the manufacturer's recommendations for weight limits for towed equipment and towing on slopes. Use counterweights or wheel weights as described in the machine operator's manual.
- Do not turn sharply. Use additional caution when turning or operating under adverse surface conditions. Use care when reversing.
- Do not shift to neutral and coast downhill.

Safety

Read the general safety operating precautions in your machine operator's manual for additional safety information.

Protect Bystanders

- Keep bystanders away when you operate.
- Before you back machine and attachment, look carefully behind attachment for bystanders.

Keep Feet From Under Drawbar

Before you disconnect attachment from machine hitch plate:

- Unload attachment.
- Stop attachment on level ground.
- Stop engine.
- Lock park brake.
- Block attachment wheels.
- Make sure feet are not under drawbar.

Wear Appropriate Clothing

- Always wear eye protection when operating the machine.
- Wear close fitting clothing and safety equipment appropriate for the job.

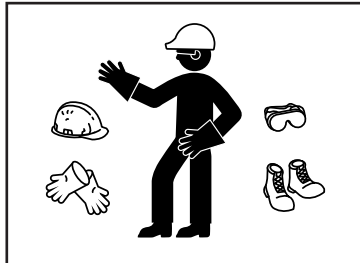

- While operating this machine, always wear substantial footwear and long trousers. Do not operate the equipment when barefoot or wearing open sandals.
- Wear a suitable protective device such as earplugs. Loud noise can cause impairment or loss of hearing.

Practice Safe Maintenance

- Understand service procedure before doing work. Keep area clean and dry.
- Remove all weight and/or material from attachment before disconnecting unit from tractor.



- Never lubricate, service, or adjust machine while it is moving. Keep safety devices in place and in working condition. Keep hardware tight.
- Keep hands, feet, clothing, jewelry, and long hair away from any moving parts, to prevent them from getting caught.
- Lower attachments to the ground before servicing machine. Disengage all power and stop the engine. Lock park brake and remove the key. Let machine cool.
- Keep all parts in good condition and properly installed. Fix damage immediately. Replace worn or broken parts. Replace all worn or damaged safety and instruction decals.

Parking Safely

1. Stop machine on a level surface, not on a slope.
2. Disengage mower blades.
3. Lower attachments to the ground.
4. Lock the park brake.
5. Stop the engine.
6. Remove the key.
7. Wait for engine and all moving parts to stop before you leave the operator's seat.
8. Close fuel shut-off valve, if your machine is equipped.

Safety / Specifications

Tire Safety

Explosive separation of a tire and rim parts can cause serious injury or death:

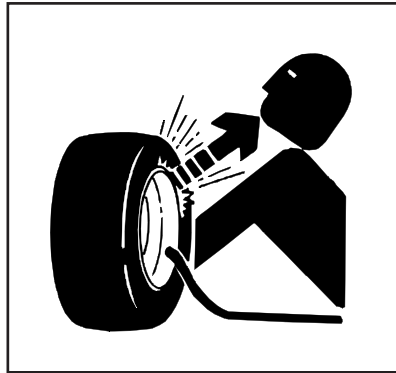

- Do not attempt to mount a tire without the proper equipment and experience to perform the job.
- Always maintain the correct tire pressure. Do not inflate the tires above the recommended pressure. Never weld or heat a wheel and tire assembly. The heat can cause an increase in air pressure resulting in a tire explosion. Welding can structurally weaken or deform the wheel.
- When inflating tires, use a clip-on chuck and extension hose long enough to allow you to stand to one side and NOT in front of or over the tire assembly.
- Check tires for low pressure, cuts, bubbles, damaged rims or missing lug bolts and nuts.

Specifications

Model SAT-400JD

Width	102 cm (40 in.)
Tine Penetration	Up to 51 mm (2 in.)
Number of Tines	132
Tine Spacing	89 mm (3.5 in.)
Weight Tray Capacity	45 kg (100 lb)

Tires

Size	4.10 x 3.5-4
Maximum Air Pressure	206 kPa (30 psi)

Parts

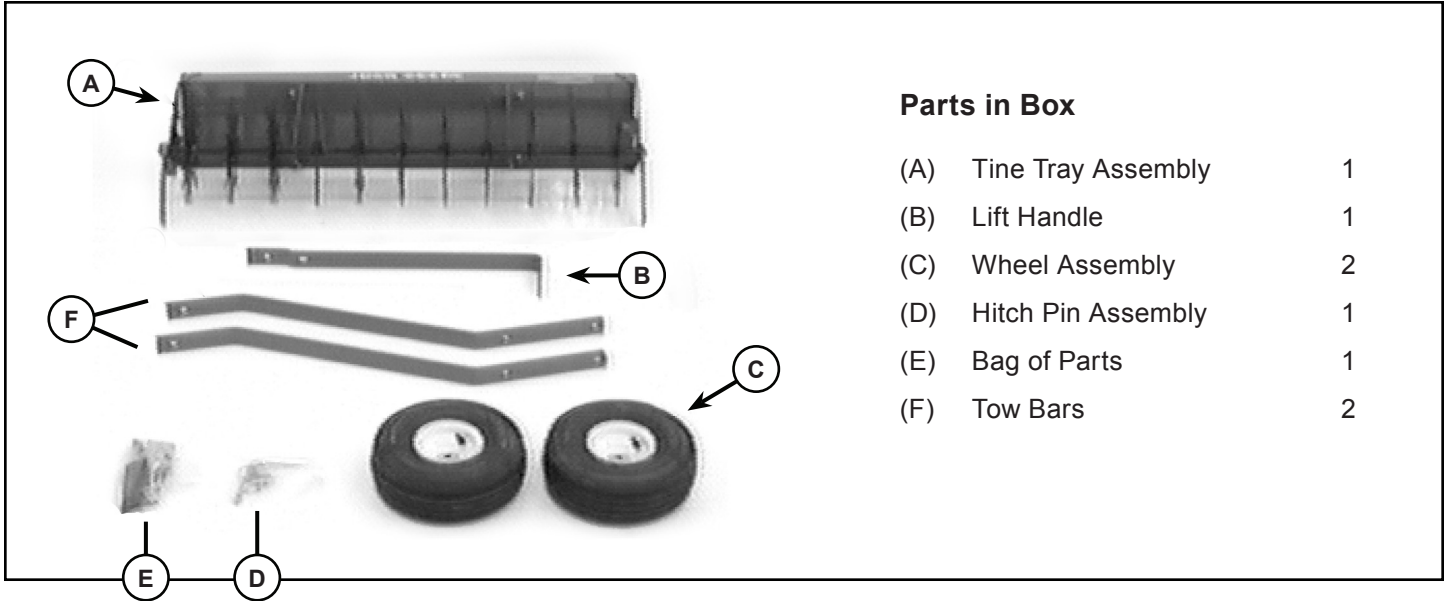

Parts in Box

(A)	Tine Tray Assembly	1
(B)	Lift Handle	1
(C)	Wheel Assembly	2
(D)	Hitch Pin Assembly	1
(E)	Bag of Parts	1
(F)	Tow Bars	2

Bag of Parts

(G)	Bolt; Hex, 5/16 x 1 in.	4	(P)	Lockwasher, 5/16 in.	2
(H)	Bolt; Hex, 5/16 x 1-1/2 in.	1	(Q)	Lockwasher, 1/2 in.	2
(I)	Bolt; Hex, 1/2 x 3-3/4 in.	2	(R)	Washer; Flat, 5/16 in.	5
(J)	Bolt; Carriage, 5/16 x 2-1/4 in.	2	(S)	Washer; Flat, 3/8 in.	1
(K)	Bolt; Special Plow, 3/8 x 2 in.	1	(T)	Washer; Flat, 1/2 in.	4
(L)	Nut; Nylock, 5/16 in.	7	(U)	Spring	1
(M)	Nut; Hex, 5/16 in.	2	(V)	Vinyl Handle Grip	1
(N)	Nut; Hex, 1/2 in.	4	(W)	Painted Clevis	2
(O)	Locknut; Oblong, 3/8 in.	1	(X)	Transport Lock Pin	2

Assembly

Step 1-A. Assemble Tow Bars

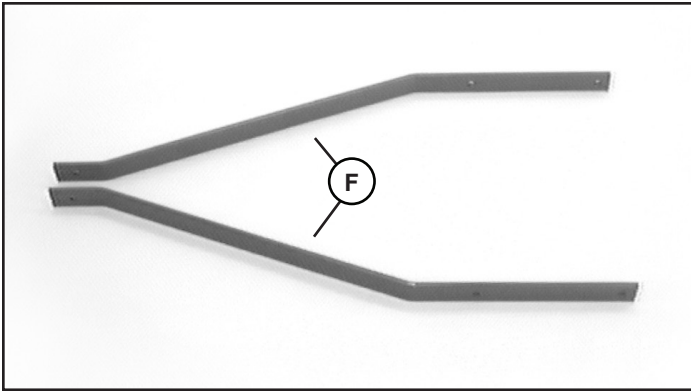

1. Align tow bars (F) as shown.

Step 1-B. Assemble Tow Bars

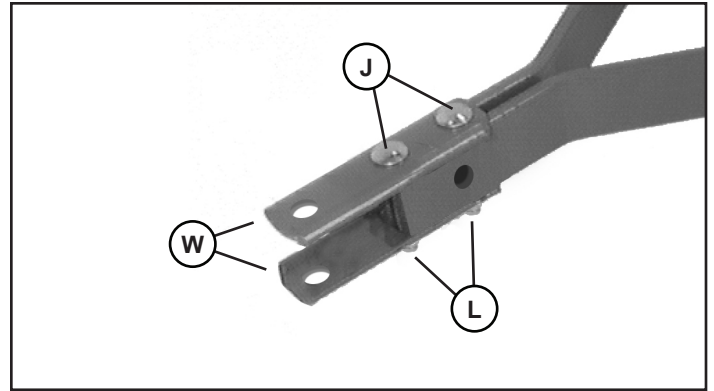

2. Assemble two clevis straps (W) to front of tow bars using two 5/16 x 2-1/4 in. carriage bolts (J) and two locknuts (L). Hand tighten only.
3. Slide clevis assembly forward until front carriage bolt is within 6 mm (1/4 in.) from the end of tow bars.

Step 1-C. Assemble Tow Bars

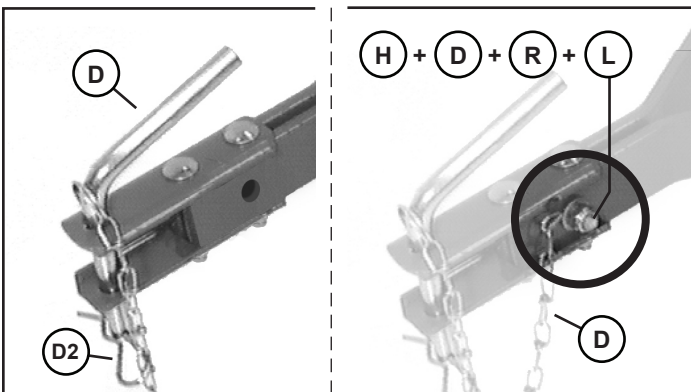

4. Install hitch pin (D) in clevis and fasten with spring locking pin (D2) through chain loop.
5. Install 5/16 x 1-1/2 in. cross hex bolt (H). Place chain hook (D) around bolt and secure with 5/16 in. flat washer (R) and locknut (L).

Step 1-D. Assemble Tow Bars

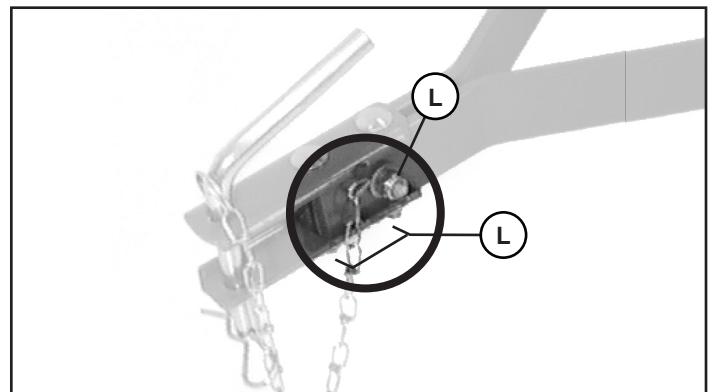

6. Align tow bars and clevis. Tighten nuts (L) completely.
7. Tighten nylock nut (L) while holding chain hook forward and centered between clevis halves.

Assembly

Step 2-A. Install Tow Bars to Tray Assembly

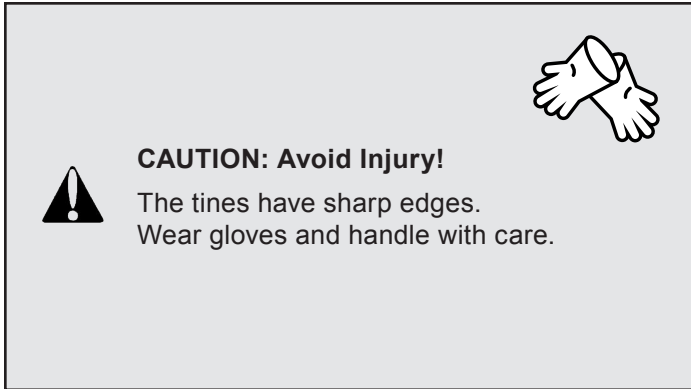

NOTE: You may want to get a helper or use a hoist to steady tow bars during alignment.

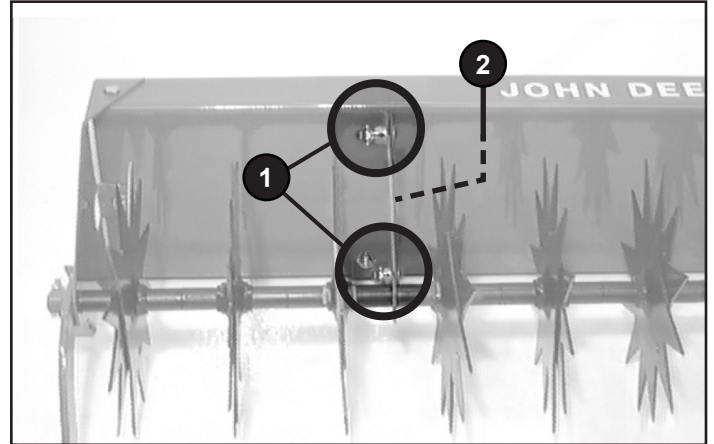

1. Stand tray assembly on its back. Loosen nylock nuts (1) on mounting brackets (2) to ensure proper bracket alignment while installing tow bars.

Step 2-B. Install Tow Bars to Tray Assembly

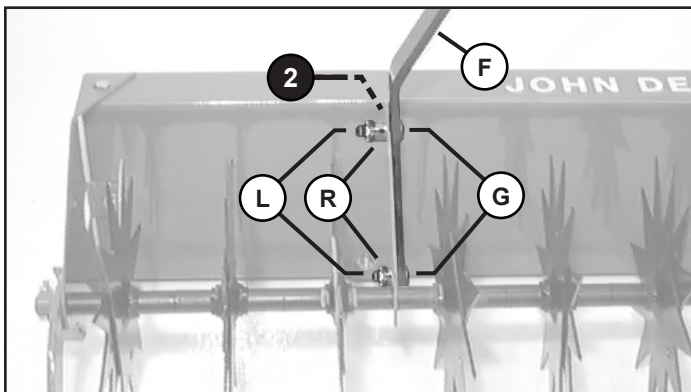

2. Align tow bars (F) to the insides of brackets (2). Fasten with two 5/16 x 1 in. hex bolts (G), flat washer (R), and nylock nuts (L). Hand tighten only. Repeat for other side.
3. Hold tow bars all the way to top of slots and tighten nylock nuts (L).
4. Tighten nylock nuts (1, from Step 2-A) on mounting brackets (2).

Step 3-A. Assemble Transport Wheels

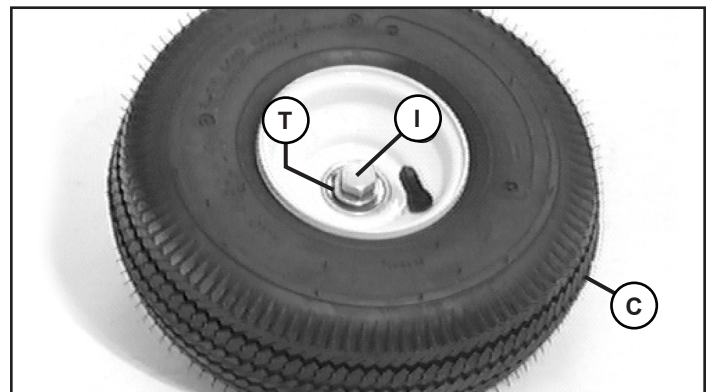

1. Install 1/2 x 3-3/4 in. hex bolt (I) and 1/2 in. flat washer (T) on valve stem side of wheel hub (C).

Picture Note: Outside edge of the wheel shown

Assembly

Step 3-B. Assemble Transport Wheels

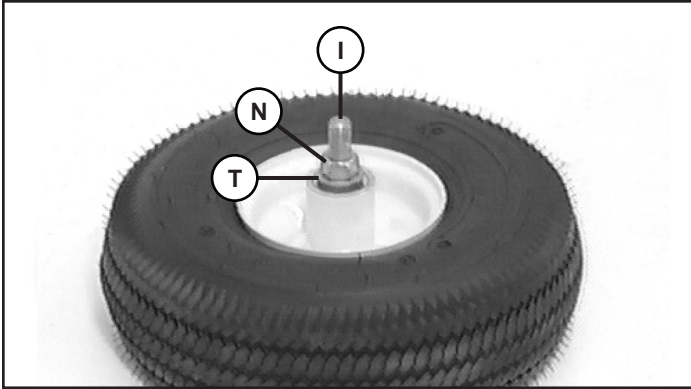

2. Turn wheel over to install second 1/2 in. flat washer (T) and 1/2 in. hex nut (N).
3. Tighten nut (N) until washers (T) and (T) keep bearing from turning on bolt without forcing bearings to be pressed inward. This causes wheel hub to rotate on bearings.

Picture Note: Outside edge of the wheel shown

Step 3-C. Assemble Transport Wheels

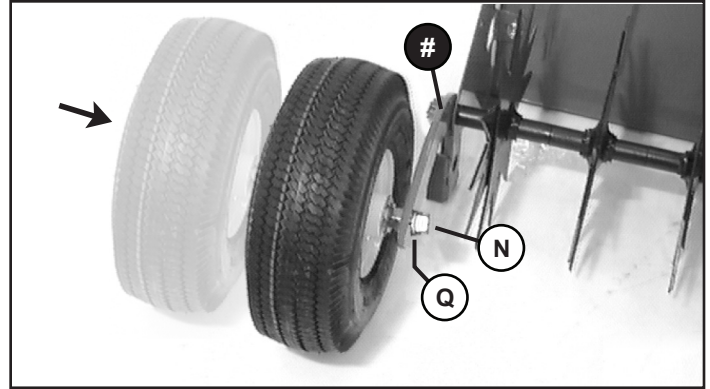

4. Install wheel assembly on lift arm (#), one on each side, and secure with 1/2 in. lockwasher (Q) and 1/2 in. hex nut (N). Tighten nut securely so wheel hubs are free to turn on bearings.

Step 4-A. Install Lift Lever

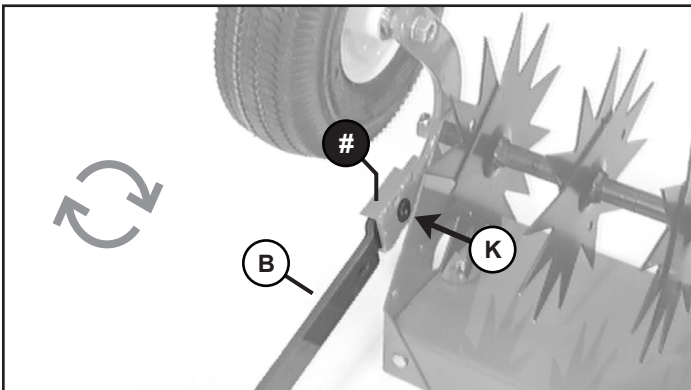

CAUTION: Avoid Injury! Tines have extremely sharp points. Wear gloves and handle with care.

1. Turn tray on its top and align lift lever (B), with offset to outside, to right side of lift arm (#).
2. With the head of bolt to the inside, run a 3/8 x 2 in. flat-top beveled carriage bolt (K) through the lift lever and arm.

Step 4-B. Install Lift Lever

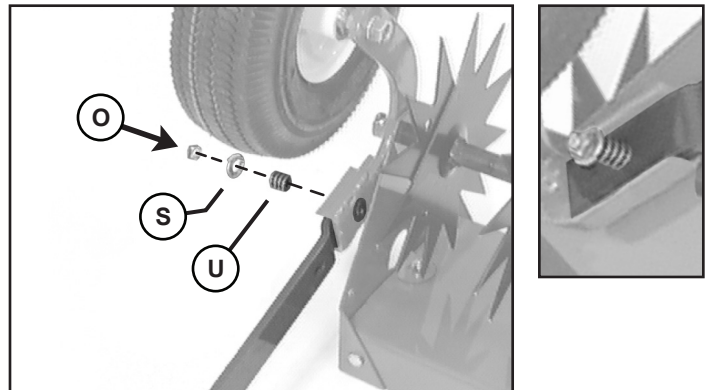

3. To secure the carriage bolt (from **Step 4-A**) on the outside edge, add the spring (U), 3/8 in. flat washer (S), and 3/8 in. oblong locknut (O).

NOTE: Be sure head of carriage bolt (K) is properly sealed in square hole of wheel assembly bracket during tightening of locknut (O).

4. Tighten locknut (O) until one full thread is exposed.

Assembly

Step 4-C. Install Lift Lever

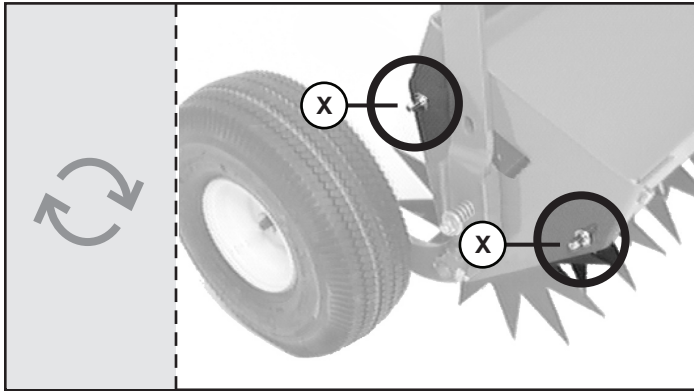

5. Turn tray upright and install two 5/16 in. transport lock pins (**X**), extending pin to the outside, and fasten with 5/16 in. lockwashers (**P**), and 5/16 in. hex nuts (**M**) to the inside.

Tighten nuts.

Step 4-D. Install Lift Lever

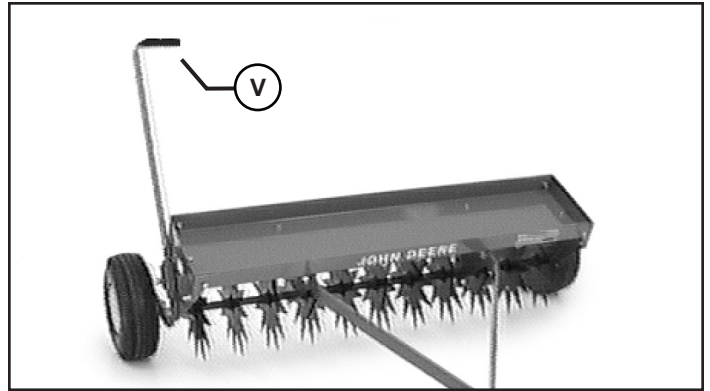

6. Install grip (**V**) on lift lever.

Installing / Removing

Installing

1. Park tractor safely.
(See *Parking Safely in the SAFETY section.*)
2. Place the attachment behind the tractor.

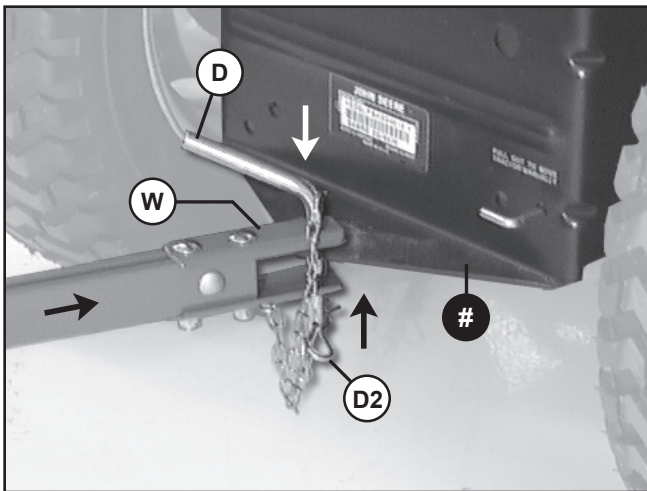

3. Place clevis (W) onto tractor hitch plate (#). Align the hitch pin holes.
4. Install hitch pin (D) through holes in clevis (W) & hitch plate (#).
5. Secure spring locking pin (D2) through hole in hitch pin (D).

Removing

1. Park tractor safely.
(See *Parking Safely in the SAFETY section.*)



CAUTION: Avoid Injury! Do not attempt to disconnect attachment from tractor with weight or spreading material remaining in the unit. Attachment could become unstable causing injury.

2. Remove all weight and/or material from attachment.

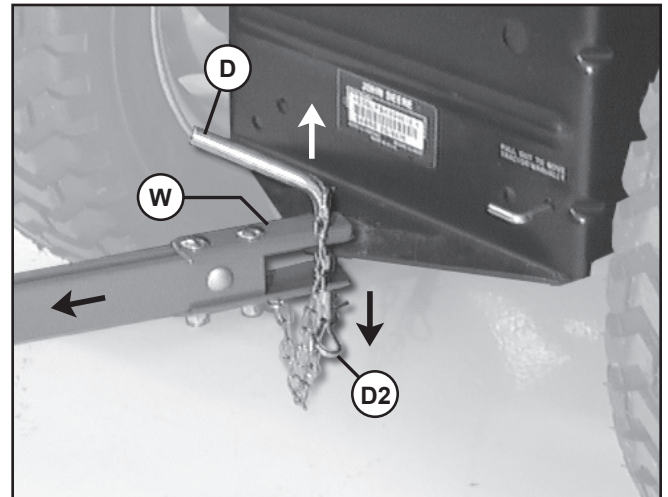

3. Remove spring locking pin (D2).
4. Remove hitch pin (D).
5. Move attachment off tractor hitch plate.
6. Install hitch pin (D) and spring locking pin (D2) to clevis (W) for storage.

Operation

When to Use the Spike Aerator

The spike aerator will actively penetrate soil, allowing much needed air, water and nutrients to enter the lawn. It will also relieve soil compaction.

A moderate soil moisture content is important to proper operation of the spiker aerator. Penetration will not occur in extremely dry soil, and very wet conditions will cause the unit to “bog down,” possibly causing lawn damage.

Use the spike aerator only on an established lawn, never on newly laid sod. The spike aerator should not be used when lawn conditions are too wet or too dry.

TO DETERMINE CONDITION: Dig a small amount of your soil about 76 mm (3 in.) deep.

Too Dry: If soil appears powdery and brittle, it is too dry. Wait until a later date, after a rainfall.

If soil is too dry, the aerator tines will not penetrate properly.

Too Wet: If soil appears damp, attempt to roll a small amount into a ball in the palm of your hand. If it forms a ball, the soil is too wet. Ideally, the soil should fall apart. Wait until the soil is more dry.

If the soil is too wet, the aerator tines will stop up and your tractor could lose traction and damage the lawn.

Selecting the Operating Positions



CAUTION: Avoid Injury! Do not operate lift handle unless attachment is installed to tractor.

Lift handle is under tension when using ballast in weight tray. *Use caution when moving handle into different positions.*

Keep hands and feet away from tines when lowering to the ground.

1. Park tractor safely.
(See *Parking Safely in the SAFETY section*).
2. Attach spike aerator to tractor.

3. Push the lift handle (F) toward the right side of machine, away from side plate (#).

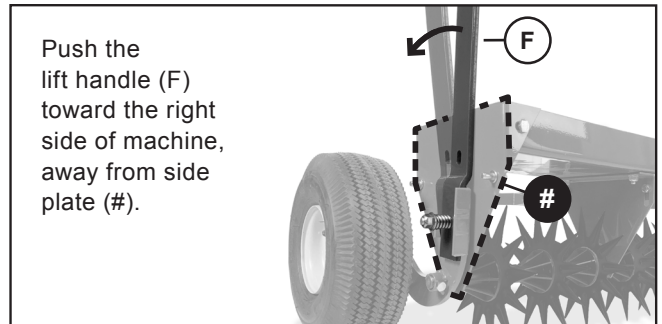

4. Move handle forward or rearward to engage lock pin into desired position:

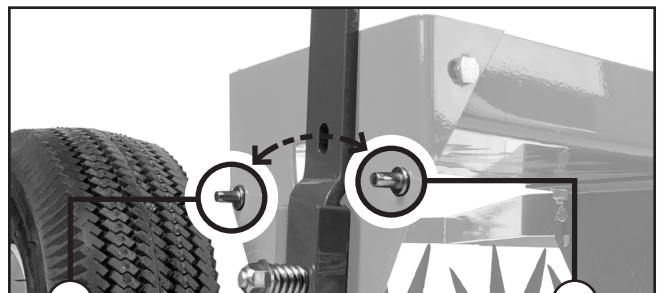

1

Transport

Use rear lock pin to raise tines so unit can be towed without tines contacting the ground.

2

Operate

Use front lock pin to lower tines to ground for operation.

Operation

Using the Weight Tray



CAUTION: Avoid Injury!

Never add weight to tray unless the attachment is installed to tractor.

CAUTION: Avoid Damage!

Never exceed the weight tray capacity of 45 kg (100 lb)



1. Install spike aerator to tractor.
2. Place lift handle in rear hole for transport position.

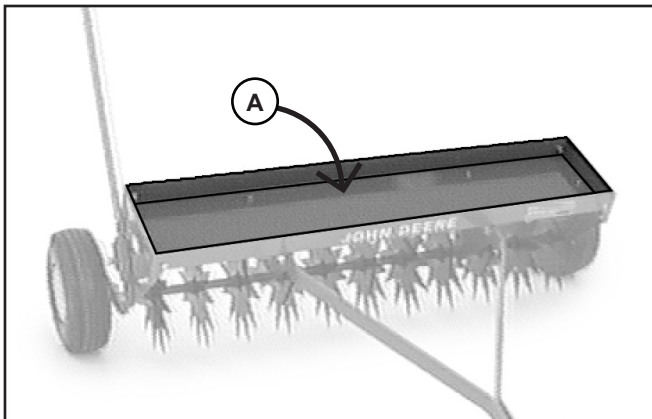

3. Add sand bags, concrete blocks, or other type of weight to weight tray (A). Do not exceed 45 kg (100 lbs) of weight. Distribute weight evenly across tray to ensure equal pressure on tines.
4. If necessary, secure weight in tray using straps.

Operating Spike Aerator



CAUTION: Avoid Injury!

Keep hands and feet away from all moving parts. Never carry riders.

IMPORTANT: Avoid Damage! Never exceed the weight tray capacity of 45 kg (100 lb).

Engage wheels to transport position when crossing concrete or asphalt surfaces.

Always back carefully in a straight line to avoid jackknifing the attachment.

Periodically remove debris build up that can restrict or damage the tines.

1. Park tractor safely.
(See *Parking Safely in the SAFETY section*).
2. Install spike aerator to tractor.
3. Place unit in transport position.
4. Add recommended weight to weight tray.
5. Drive to work area.
6. Park tractor safely.
7. Place unit in operating position.
8. Start machine.
9. Tow spike aerator at 5 to 8 km/hr (3 to 5 mph) for safe and effective operation.
10. Check for uniform hole pattern and depth. Park tractor safely before making any adjustments.

Maintenance / Service

Checking the Tine Operation

Operation of the tines will vary with soil type, condition, and amount of weight in weight tray. Make sure soil conditions are appropriate for operation. Do not exceed the weight tray capacity to try and improve penetration in overly dry conditions.

- Test operation of the tines by driving the tractor forward about 3m (10 ft). Observe the operation. Check for uniform hole pattern and depth.
- Add, remove, or distribute the weight better to obtain proper results.
- Periodically, check the tines. Remove any debris build up that might restrict or cause damage to the tines.

Service



CAUTION: Avoid Injury!

Aerator tines are sharp. Wear gloves and handle with care. Shield sharp parts during service work.

- To prevent or eliminate rust on tines, apply a light oil on them after each use.
- For rust appearing on any part of your attachment, sand lightly and coat with enamel.
- Apply a drop of lubricating oil to each nylon / line bearing assembly, axles and working area of the plugging spoons before use.
- Periodically check the aerating tines. Remove any debris that might build up and restrict their action.
- Periodically check tightness of all fasteners.
- Be sure to remove all unused fertilizers from hopper immediately after use and clean with water to prevent corrosion.

Checking Tractor Ground Speed

Check the ground speed in an open area.

- Measure a test area that is 30.5 m (100 ft) in length.
- Operate the tractor at wide open throttle. Operate tractor at a low speed and drive the tractor to test distance. Record the time needed to travel that distance.
- Make three passes, recording the time for each pass. The average time should be 14 to 23 seconds to achieve the recommended operating speed range:
 - At 4.8 km/h (3 mph), the average time traveling the test distance should be 23 seconds.
 - At 8 km/h (5 mph), the average time traveling the test distance should be 14 seconds.
- Adjust speed accordingly to achieve the recommended speed range.

Storage

Storing the Attachment



CAUTION: Avoid Injury!

Tines are sharp. Wear gloves and handle with care. Store attachments so sharp points are shielded from contact.

1. Park tractor safely.
(See Parking Safely in the SAFETY section).
2. Remove all weight and material from attachment.
3. Remove attachment from tractor.
4. Wash attachment thoroughly.
Allow to dry completely.
5. Replace all worn, damaged, or missing parts.
6. Sand any rusted areas lightly and paint with enamel.
7. Lubricate moving parts.
8. Apply a light coverage of oil to all tines to prevent rust.
9. Reduce air pressure in tires.
10. Store attachment in a dry area with tines against wall or floor to avoid accidental contact.
11. Block up attachment off the ground to prevent contact with moisture and take weight of the tires.
12. Place a waterproof cover over the attachment if it must be stored outside.

Removing the Attachment from Storage



CAUTION: Avoid Injury!

Tines are sharp. Wear gloves and handle with care. Store attachments so sharp points are shielded from contact.

1. Wash the attachment if necessary.
Allow to dry completely.
2. Inspect tires for deterioration.
3. Inflate tires to proper pressure.
4. Make sure all parts are in place and hardware is secure.

Quality

John Deere Quality Continues with Quality Service

John Deere provides a process to handle your questions or problems, should they arise, to ensure that product quality continues with quality parts and service support.

Follow the steps below to get answers to any questions you may have about your product.

1. Refer to your attachment and machine operator manuals.
2. In North America or Canada, call Brinly-Hardy Co. Customer Service at 1-866-218-8622 and provide product serial number (if available) and model number.

Notes:

This product was manufactured by Brinly-Hardy Co., a John Deere Licensee, located at 3230 Industrial Pkwy, Jeffersonville, IN 47130. If you have any questions or concerns with the assembly, installation or operation of this attachment see your local John Deere Dealer or call Brinly-Hardy Co. at 866-218-8622 for assistance.

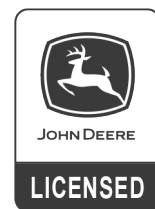

Warranty

Limited Warranty for New John Deere Licensed Products

A. General Provisions – The warranties described below are provided by manufacturer, Brinly Hardy Company, on John Deere Licensed products to the original purchaser of new Lawn and Garden attachments from authorized John Deere Dealers & Retailers. Under these warranties, the manufacturer will repair or replace, at its option, any covered part found to be defective in material or workmanship during the applicable warranty term. The purchaser will be responsible, however, for any service call and / or transportation of product to and from the dealer's place of business, for any premium charged for overtime labor requested by the purchaser, and for any service and/or maintenance not directly related to any defect covered under the warranties below.

B. What is warranted – All parts of any new John Deere Licensed product, are warranted for the number of months specified below. When you call please have the serial number, if applicable, and model number.

C. What is not warranted – 1) Used products; (2) Any product that has been altered or modified in ways not approved by the manufacturer; (3) Depreciation or damage caused by normal wear, lack of reasonable and proper maintenance, failure to follow operating instructions, misuse, lack of proper protection during storage, or accident; (4) normal maintenance parts and service.

D. Securing Warranty Service – To secure warranty service, the purchaser must (1) report the product defect to an authorized dealer, or to the manufacturer by calling 866-218-8622, and request repair within the applicable

warranty term, (2) present evidence of the warranty start date, and (3) make the product available to the dealer or service center within a reasonable period of time.

E. Limitation of implied warranties and other remedies – To the extent permitted by law, neither John Deere nor any company affiliated with it makes any warranties, representations or promises as to the quality, performance or freedom from defect of the equipment covered by this warranty. Implied warranties of merchantability and fitness for a particular purpose, to the extent applicable, shall be limited in duration to the applicable period of warranty set forth on this page. The purchaser's only remedies in connection with the breach or performance of any warranty on the John Deere Lawn and Garden attachments are those set forth on this page. In no event will the Dealer, John Deere or the manufacturer be liable for incidental or consequential damages. (Note: Some states do not allow limitations on how long an implied warranty lasts or the exclusion or limitation of incidental or consequential damages so the above limitations and exclusions may not apply to you.) This warranty gives you specific legal right, and you may also have other rights, which vary from state to state.

F. No Dealer Warranty – The selling Dealer makes no warranty of its own and the Dealer has no authority to make any representation or promise on the behalf of John Deere or the manufacturer to modify the terms or limitations of the warranty in any way.

Manufacturer's Lawn & Garden Attachments	*Warranty Term
Steel Frame	2 Years
Transmission (gearbox)	2 Years
Poly Hoppers & Beds	2 Years
Wheels	1 Year
Hydraulics	1 Year
Drive Gears	1 Year
Other normal wear parts	1 Year

**Each Warranty Term begins on the date of product delivery to the purchaser.*

Register your John Deere Licensed Product by completing & mailing in the enclosed Warranty Registration Card.
For Customer Service: Please call 866-218-8622