

ASSEMBLY AND INSTALLATION INSTRUCTIONS

T0764

WARNING: Turn off the main power at circuit breaker before installing fixture.
AVERTISSEMENT: Coupez la source d'alimentation principale au panneau central de disjoncteurs avant d'installer le luminaire.

NOTES: 1. Before installing, consult local electrical codes for wiring and grounding requirements.
2. Read and save these instructions.

Hardware Package (included):

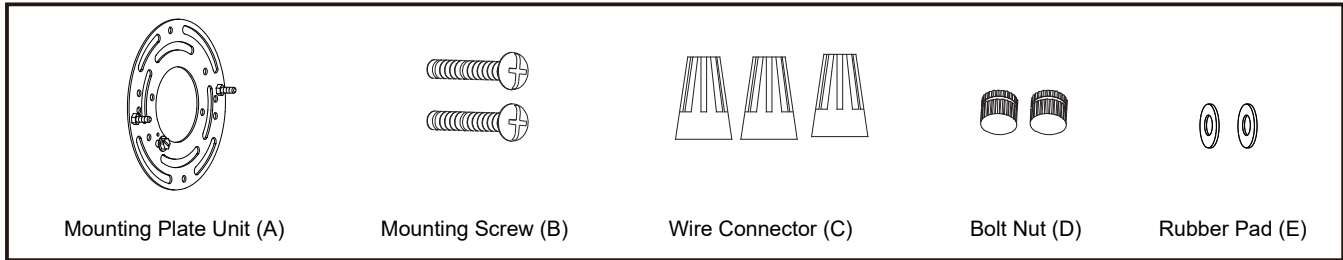

Installation Steps

Turn off the power at fuse or circuit box

1. Unscrew the two bolt nuts (D), remove the two rubber pads (E) and mounting plate unit (A) from the backplate.
2. Attach mounting plate unit (A) the outlet box by using two mounting screws (B). Adjust the length of the preinstalled fixture mounting screws if necessary.
Note: Make sure that the fixture mounting screws are lined up horizontally to make the fixture level.
3. Hook the curved end of the arm to the loop, and attach the other end of the arm to the backplate and secure it by using the rubber pad-a and the set screw, washer and the lock nut.
4. Pull out the source wires from the outlet box. Make wire connections using wire connectors (C) as follows:
 - Connect the hot wire (black insulation) from the fixture the black wire from the power source.
 - Connect the neutral wire (white insulation) the fixture to the white wire from the power source.
 - Attach the fixture ground wire (bare wire) to the mounting plate unit (A) with the green ground screw, then depending on local code, connect it to the house wire with the connector (C).

Carefully put all of the wires back into the outlet box.

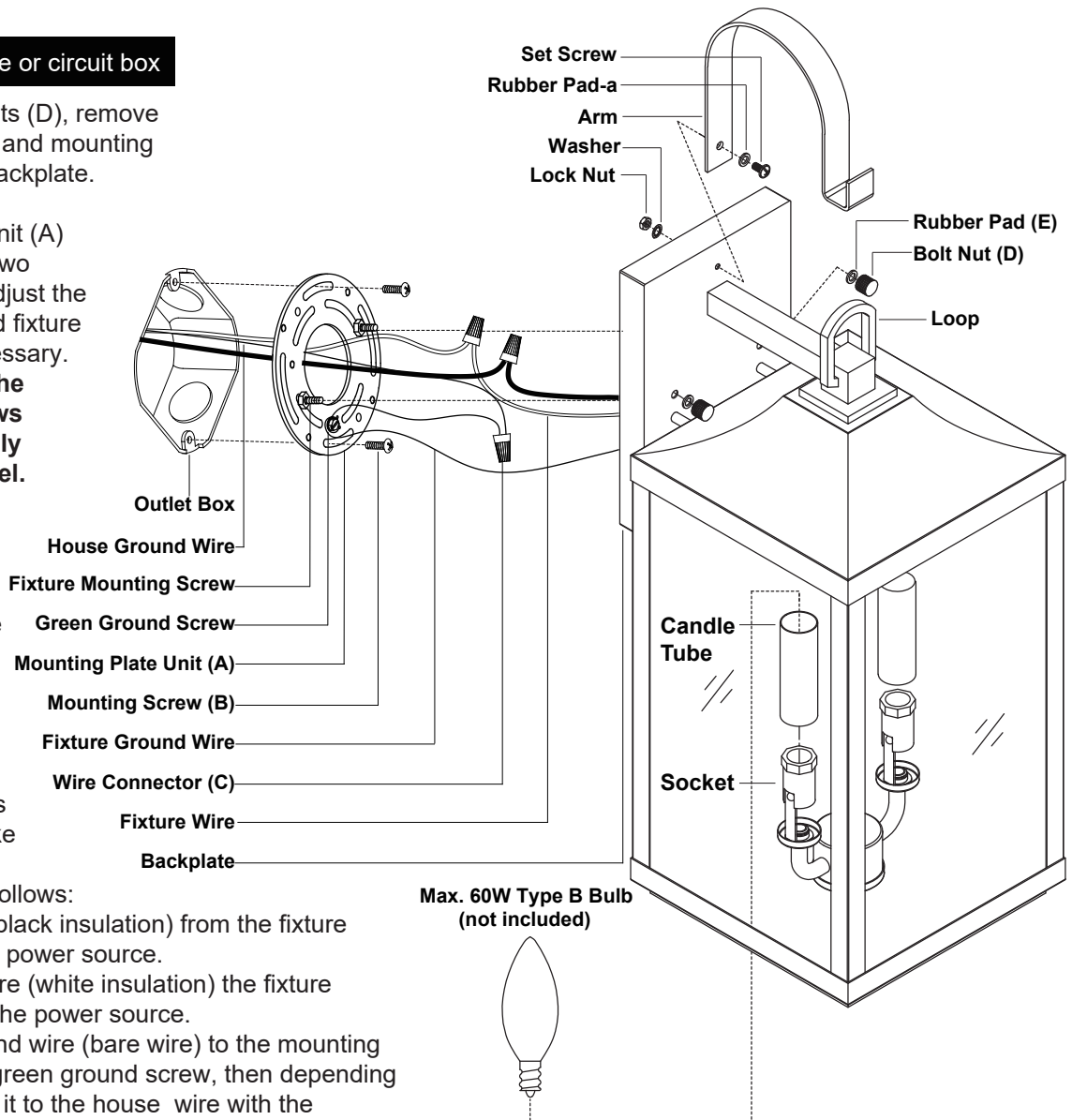

5. Attach the backplate of the fixture to the mounting plate unit (A) by aligning and inserting the two fixture mounting screws into the open holes on the backplate, then secure it with the two rubber pads (E) and two bolt nuts (D).

Note: With silicone caulk compound, caulk completely around where the backplate meets with the wall surface to prevent water from seeping into the outlet box.

6. Attach the candle tubes onto the sockets.

7. Install the bulbs (not included). See relamping label at socket area or packaging for maximum wattage allowed.

Turn on the power at fuse or circuit box

The following parts are available for reorder if damaged or missing.

Spare Parts List:

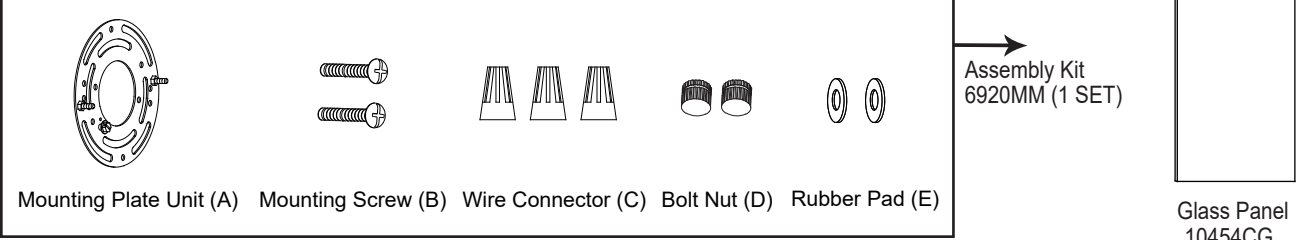

Mounting Plate Unit (A) Mounting Screw (B) Wire Connector (C) Bolt Nut (D) Rubber Pad (E)

Assembly Kit 6920MM (1 SET)

Glass Panel 10454CG

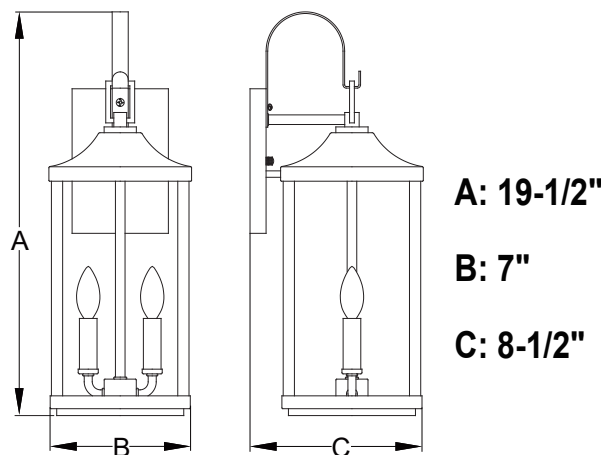

1 Year Warranty

Vaxcel warrants all of our products against defects in workmanship and finishes for one year following the date of shipment.

Exclusions: This warranty does not include the failure of products from extreme acts of nature; environmental conditions not suited for the products intended use; operation in temperatures outside of the range specified in the instruction manual; usage with improper power supply, power surges or dips. For coastal locations, some corrosion is considered normal for the environment.

Vaxcel reserves the right to repair, replace or issue a credit for any properly installed product, provided it is returned per RMA instruction. This warranty is limited to the cost of the product only and does not extend to transportation, installation or replacement costs.

How can warranty service be obtained?

info@vaxcel.com

1-800-482-9235