

SIDES	BOTTOM
20 1/2"-3/4" MOON KNOCKOUTS	8 KNOCKOUTS
	8 1/2"-3/4" MOON KNOCKOUTS
Material: Steel-0.0625"-G60 Galvanized	

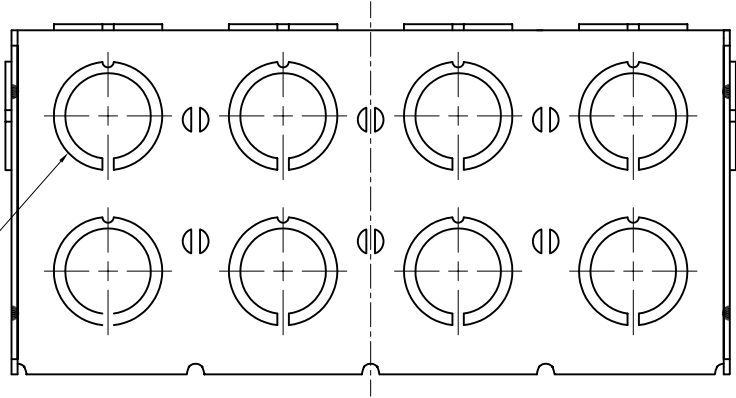

16 1/2"-3/4" MOON KNOCKOUTS $\phi=22.50[\phi=0.886]$
 $\phi=28.50[\phi=1.122]$ MIRROR

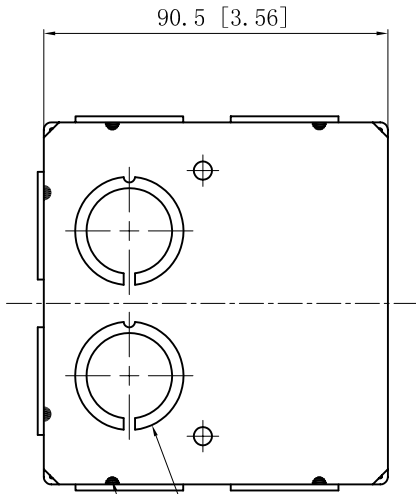
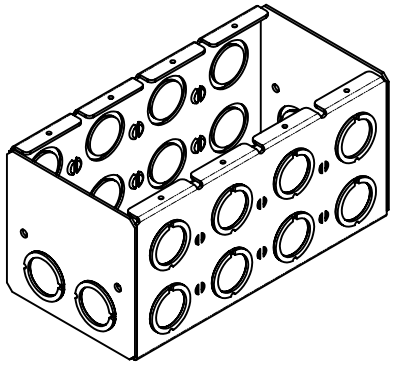

4 1/2"-3/4" MOON KNOCKOUTS $\phi=22.50[\phi=0.886]$
 $\phi=28.50[\phi=1.122]$ MIRROR

12 PLACES SPOT WELDING

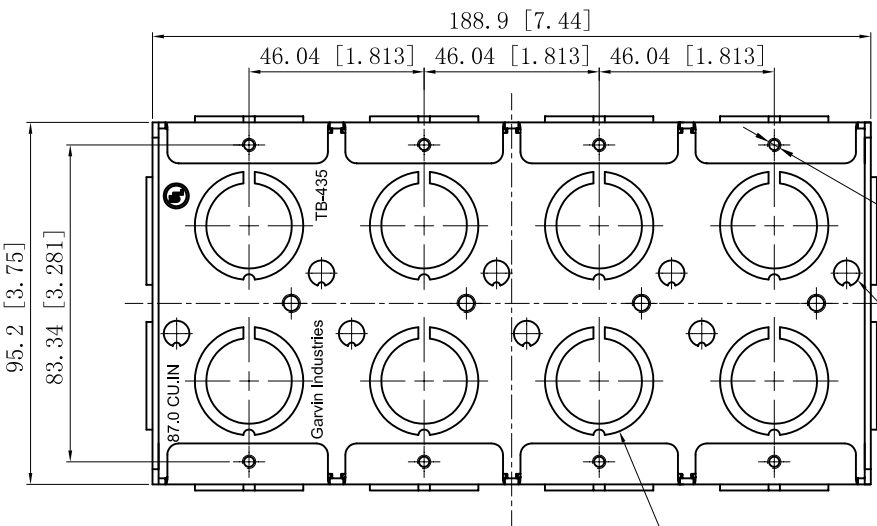

8-#6-32 UNC HOLE

8 KNOCKOUTS $\phi=6.75[\phi=0.27]$

8 1/2"-3/4" MOON KNOCKOUTS $\phi=22.50[\phi=0.886]$
 $\phi=28.50[\phi=1.122]$

This data sheet is for reference only .GARVIN INDUSTRIES reserves the right to make changes to the design without prior notice.

DESCRIPTION
TRADE REFERENCE TERMS

STANDARD PACKING
5 PCS

GARVIN INDUSTRIES		
TITLE SOLID MASONRY BOX 3-1/2" DEEP		
SIZE A4	DWG NO. TB-435	REV B
DATA SHEET		