





Thank you for purchasing this quality product. Be sure to check all packing materials carefully for small parts, which may have come loose inside the carton during shipment. Identify and count all items and compare with the PARTS LIST and/or HARDWARE LIST shown below.









Caution: Please read the instructions thoroughly before assembly.

1. We recommend that you assemble this product with the assistance of another person; this will make the assembly easier, and will help eliminate damage to the product or injury to persons during assembly.
2. Please do not over tighten screws or bolts until the assembly is completed.
3. Please put all parts on a non-abrasive floor before assembly, and follow the assembly steps to assemble your newly purchased product correctly and efficiently.

PARTS LIST

NO:	COMPONENT	SKETCH	Q'TY
A	Chair Back		2 PCS
B	Cushion seat		2 PCS
C	Front Leg		4 PCS
D	Right Side Facing (RSF) Arm		2 PCS
E	Left Side Facing (LSF) Arm		2 PCS

HARDWARE LIST

NO:	COMPONENT	SKETCH	Q'TY
1	Allen Key		1 PC
2	Long Bolt 5/16"*3-3/4"L		8 PCS
3	Medium Bolt 5/16"*2-1/4"L		10 PCS
4	Lock Washer 5/16"		18 PCS
5	Flat Washer 5/16"		18 PCS
6	Short Bolt 1/4"*1-1/2"L		4 PCS
7	Lock Washer 1/4"		4 PCS
8	Flat Washer 1/4"		4 PCS
9	Screw 8*1-1/2"		4 PCS

WEIGHT CAPACITY (PER CHAIR)	250 LBS
-----------------------------	---------

- STEP 1** Place the chair back (A) on a soft and clean surface.
 Assemble the Cushion Seat (B) with the Chair Back (A) by using Allen Key (1) with hardware 3, 4, and 5.

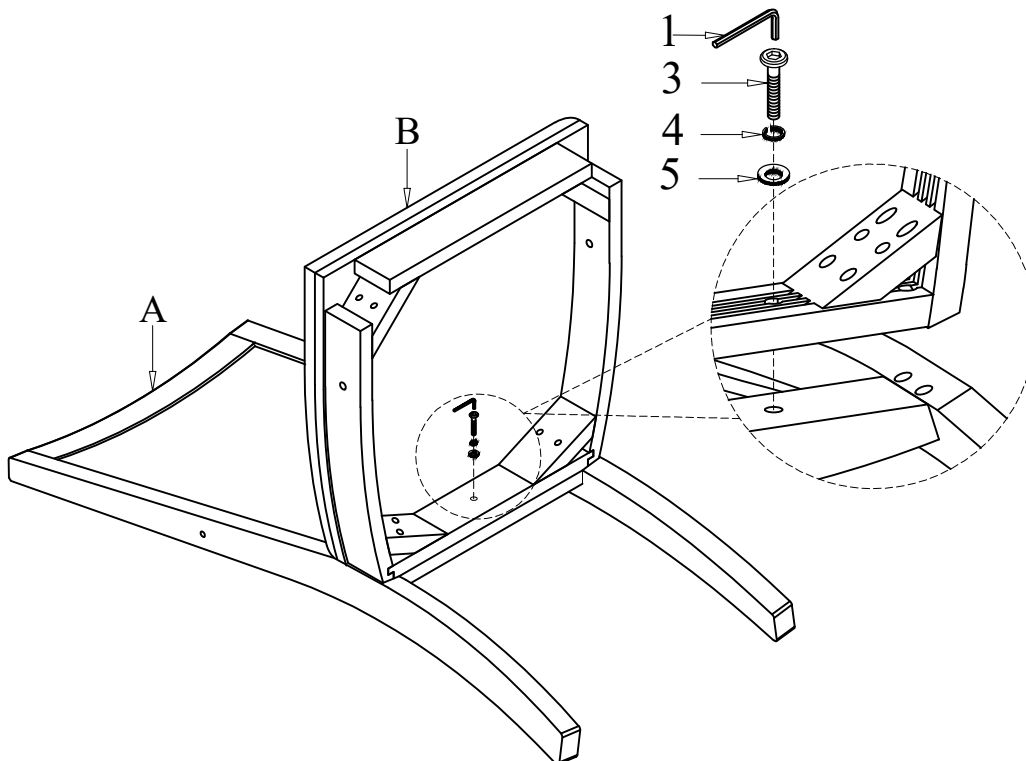

STEP 2 Assemble the Cushion Seat (B) with the back legs of the Chair Back (A) by using Allen Key (1) with hardware 2, 4, and 5.

****Attention: DO NOT TIGHTEN THE BOLTS**

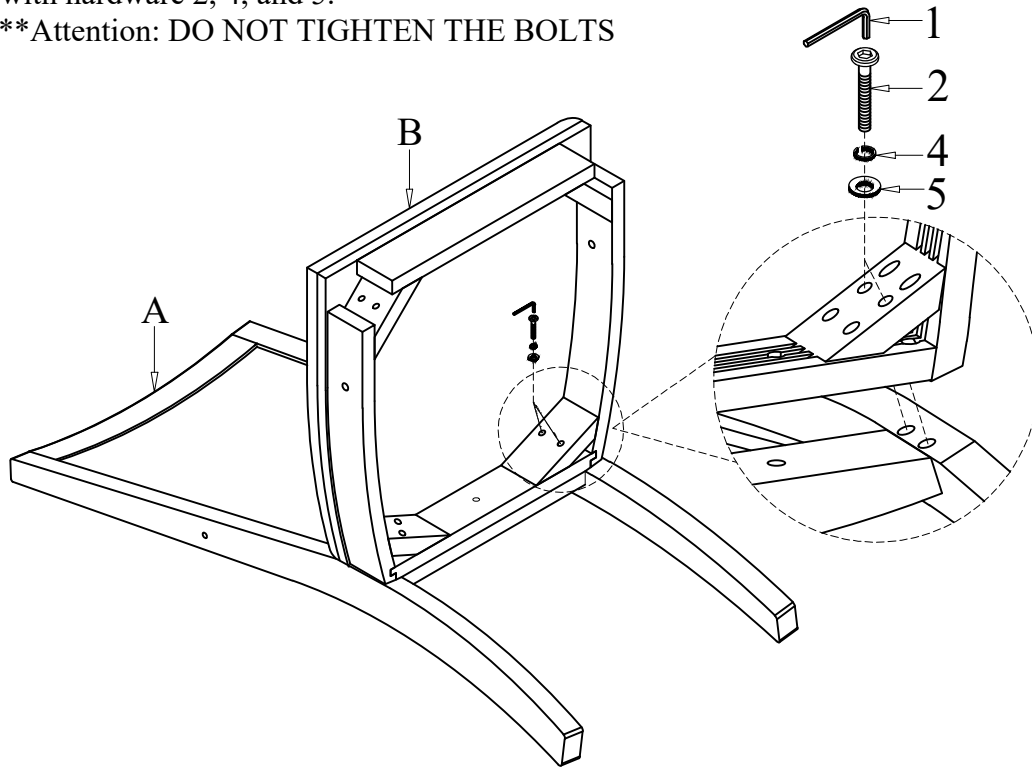

STEP 3 Assemble the Front Legs (C) with the Cushion Seat (B) by using Allen Key (1) with hardware 3, 4, and 5.

****Attention: DO NOT TIGHTEN THE BOLTS.**

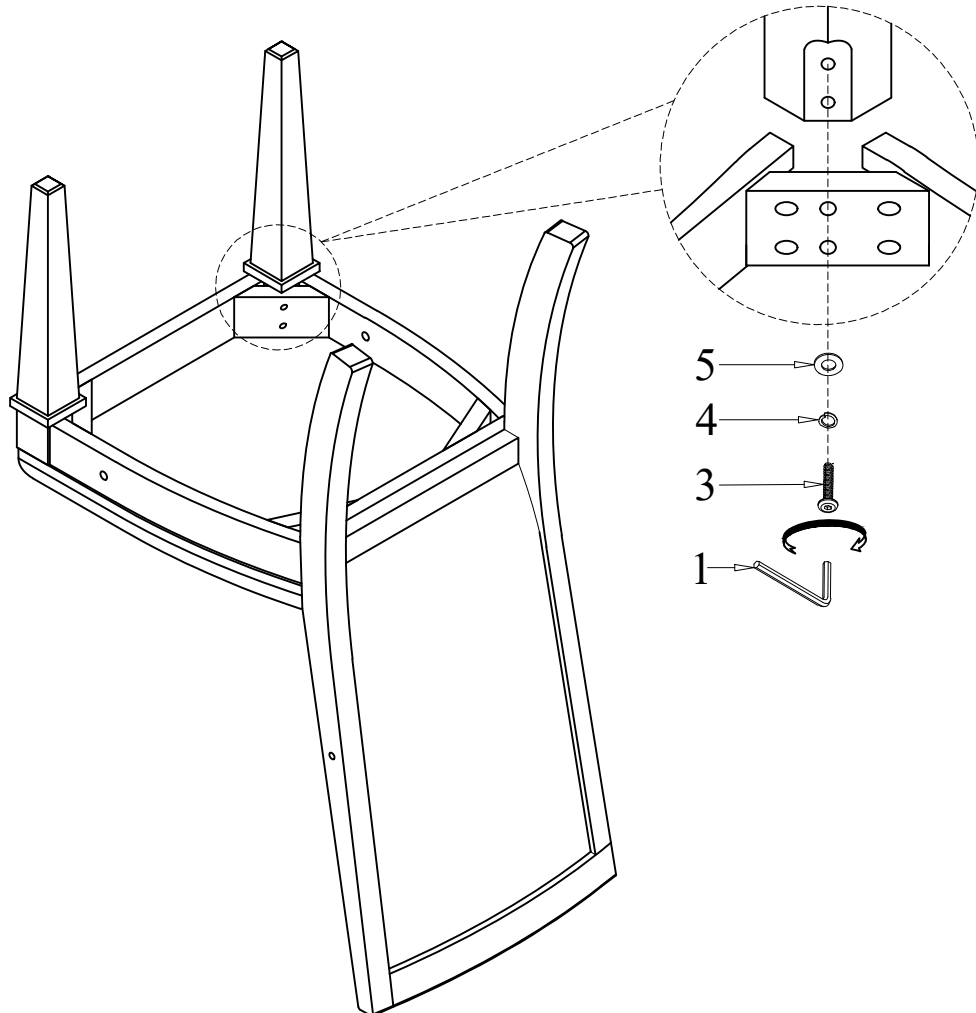

STEP 4 Assemble the RSF Arm (D) with the Cushion Seat (B) by using Allen Key (1) with hardware 6, 7, and 8. Then assemble the RSF Arm (D) with the Chair Back (A) by using a screwdriver with hardware 9. Repeat the step to assemble the LSF Arm (E).

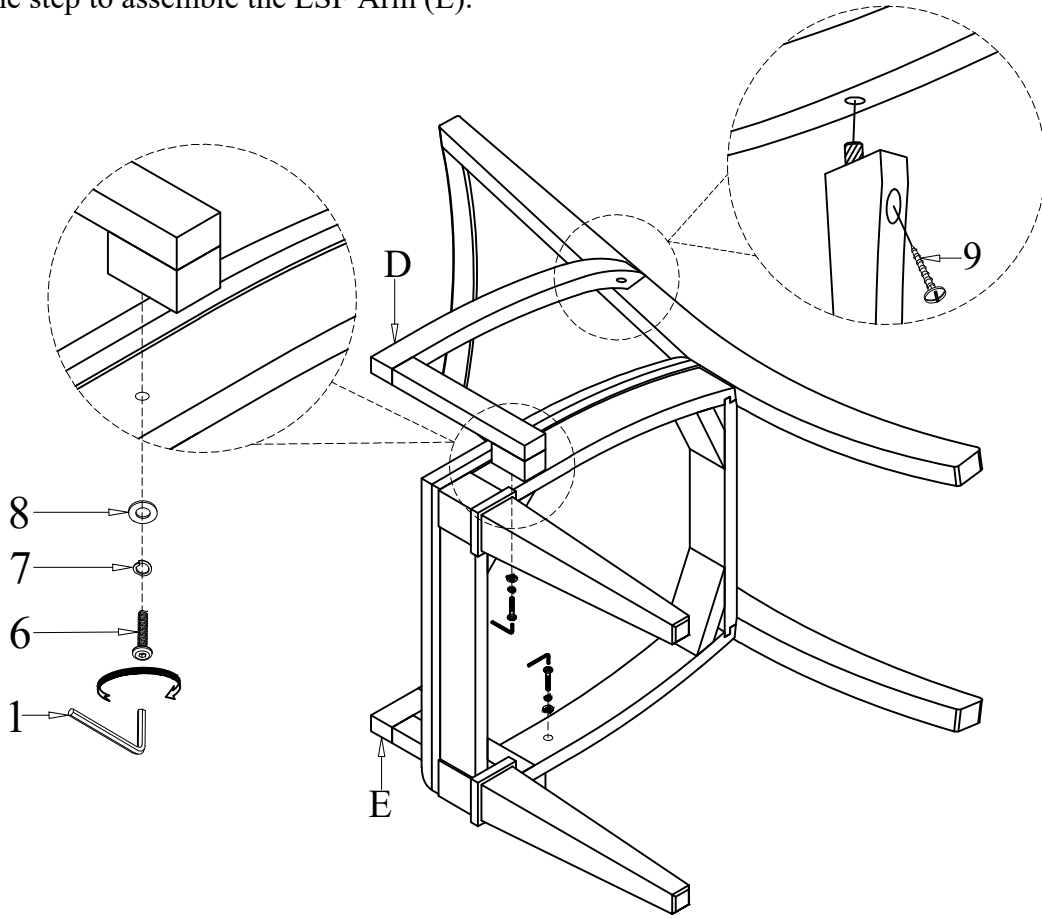

STEP 5 To level the chair, stand the chair up on a flat surface and tighten all the bolts by using Allen Key (1).

