

SIDES	BOTTOM
2 PCS 8-32×1/2 Screws Installed	
Material:Steel-0.0625"-G60 Galvanized	

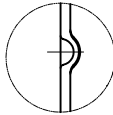

WELDING STYLE DETAIL VIEW D

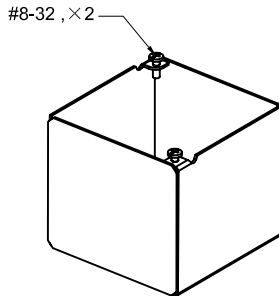
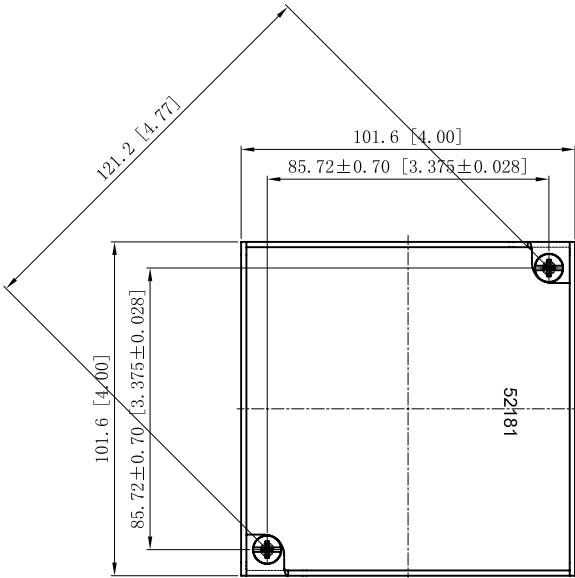
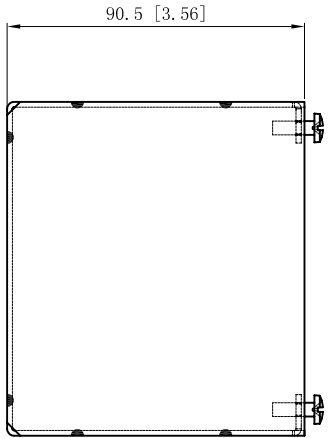
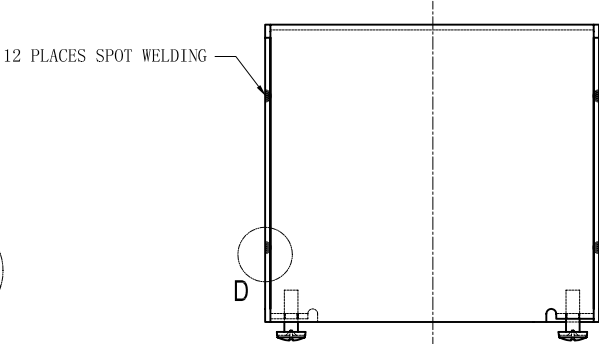

DESCRIPTION
TRADE REFERENCE TERMS

This data sheet is for reference only .GARVIN INDUSTRIES reserves the right to make changes to the design without prior notice.

STANDARD PACKING	<h1 style="text-align: center;">GARVIN INDUSTRIES</h1>			
10 PCS				TITLE
	SIZE	DWG NO.	REV	
	A4	52181-BLNK		
		DATA SHEET		