

# JACK & JUNE

ADIRONDACK CHAIR  
JJ-CHAIR-RW

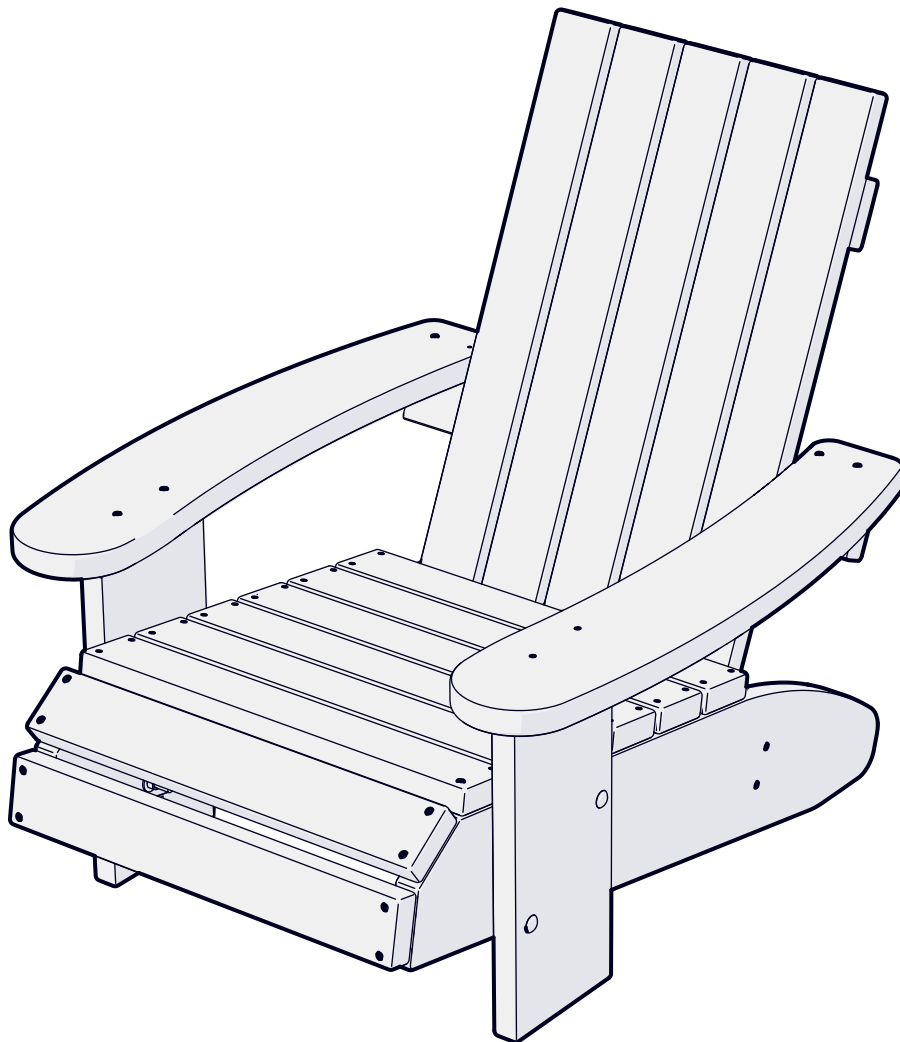

2L-6967-00

# PRE-ASSEMBLY TIPS

1. **Read this manual carefully before starting assembly.** Read each step completely before beginning each step.
2. **Some smaller parts may be shipped inside larger parts. Check inside all parts and cartons before assembling or ordering parts.**
3. **To make assembly easier, use the Hardware Identifier on page 4 to identify and sort all parts. Check all cartons for kits. All hardware may not be located in one kit.**
4. **Do not tighten until instructed to do so. If parts are tightened too soon, parts may not easily fit together. Leave nuts slightly loose until you are instructed to tighten them.**
6. **Save these instructions and your proof of purchase (receipt) in the event that the manufacturer has to be contacted for replacement parts.**

**Required Tools:**

- Phillips screwdriver
- 9/16" Wrench or Adjustable Wrench



**Please Do Not Return This Product To The Store!**

Contact Escalade<sup>®</sup> Sports customer service department at:

Phone: 1-800-GO-SWING Toll – Free !

Escalade Sports

Physical Location:

817 Maxwell Ave.  
Evansville, IN 47711

Mailing Address: (Correspondence Only)

PO Box 889  
Evansville, IN 47706

Please visit our Website at:  
[www.escaladesports.com](http://www.escaladesports.com)

ON-LINE TROUBLE SHOOTING    TECHNICAL ASSISTANCE  
ON-LINE PARTS REQUESTS    FREQUENTLY ASKED QUESTIONS  
ADDITIONAL ESCALADE<sup>®</sup>SPORTS PRODUCT INFORMATION



PARTS LIST (NOT ACTUAL SIZE)

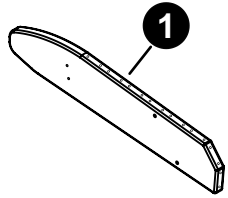

Lower Support 2x8  
PG-28-0002  
QTY.2

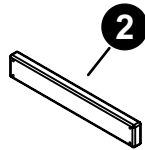

Seat Slats 2x4  
PG-24-0085  
QTY. 8

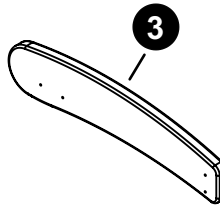

Adirondack Chair Arm  
PG-28-0001  
QTY. 2

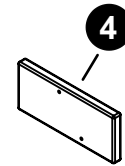

Arm Support 2x8  
PG-28-0003  
QTY. 2

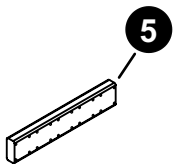

Upper Back Support 2x4  
PG-24-0082  
QTY. 1

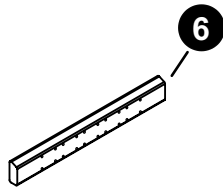

Back Support 2x4  
PG-24-0083  
QTY. 1

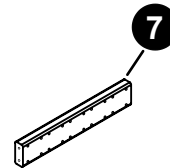

Bottom Back Support 2x4  
PG-24-0084  
QTY. 1

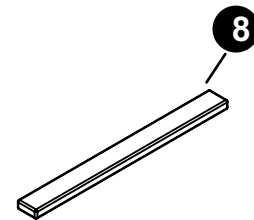

Back Slats 2x4  
PG-24-0081  
QTY. 5

## HARDWARE IDENTIFIER (ACTUAL SIZE)

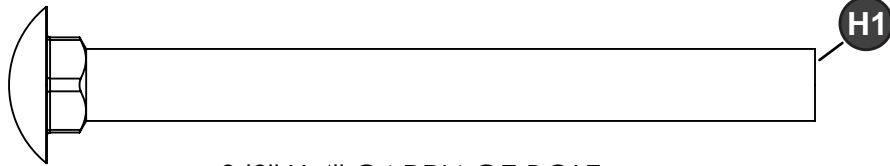

3/8" X 4" CARRIAGE BOLT  
PG-HW-B014  
QTY. 4

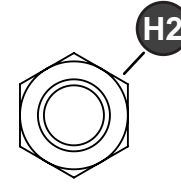

3/8" NYLON LOCKNUT  
PG-HW-N001  
QTY. 4

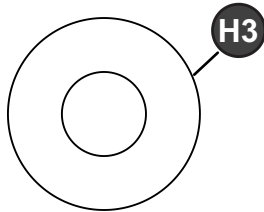

3/8" FLAT WASHER  
PG-HW-W004  
QTY. 4

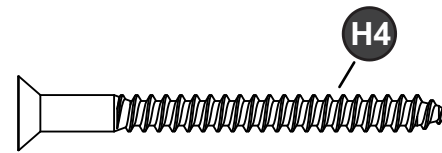

#10X2.25" FLAT HEAD WOOD SCREW  
PG-HW-S021  
QTY. 104

## TOOLS NEEDED



PHILLIPS SCREW DRIVER

### NOTE:

An electric screwdriver is helpful in assembly. However, please set at **low torque and use extreme caution** with an electric screwdriver because you could over-tighten the hardware & strip out the screws.

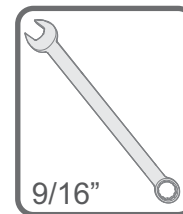

OR

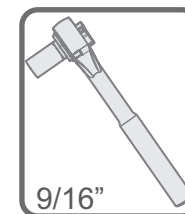

## STEP 1

On a flat surface lay five (#8) Back Slats about  $3/8$ " apart. Then lay and center (#5, #6 & #7) back supports. Attach with (H4) Screws as shown.

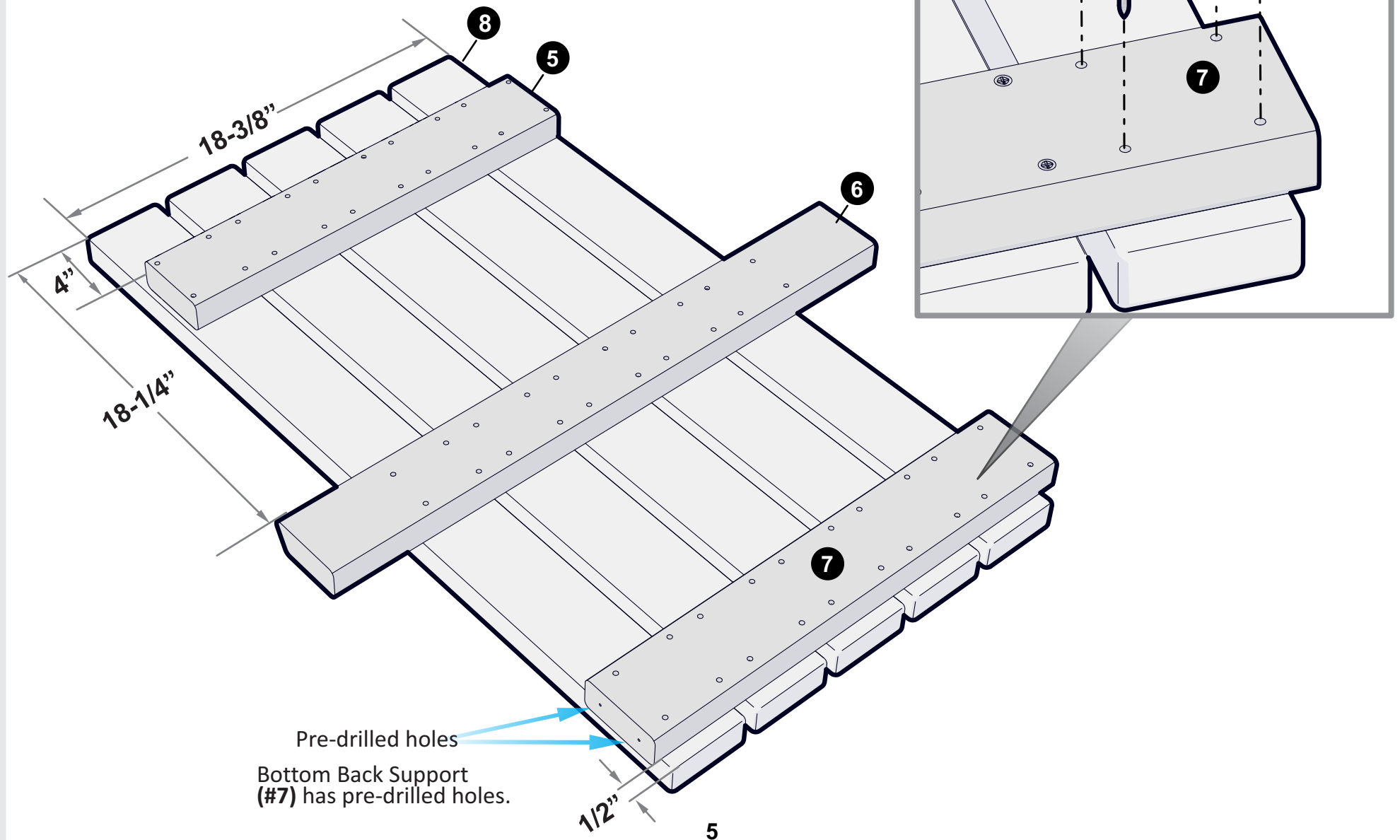

## STEP 2

On a flat surface arrange (#1) Lower Supports and attach eight (#2) Seat Slats with (#H4) Screws as shown.

**NOTE:** Lower Supports (#1) & Seats Slats (#2) are pre-drilled, make sure to match up the holes when driving the screws.

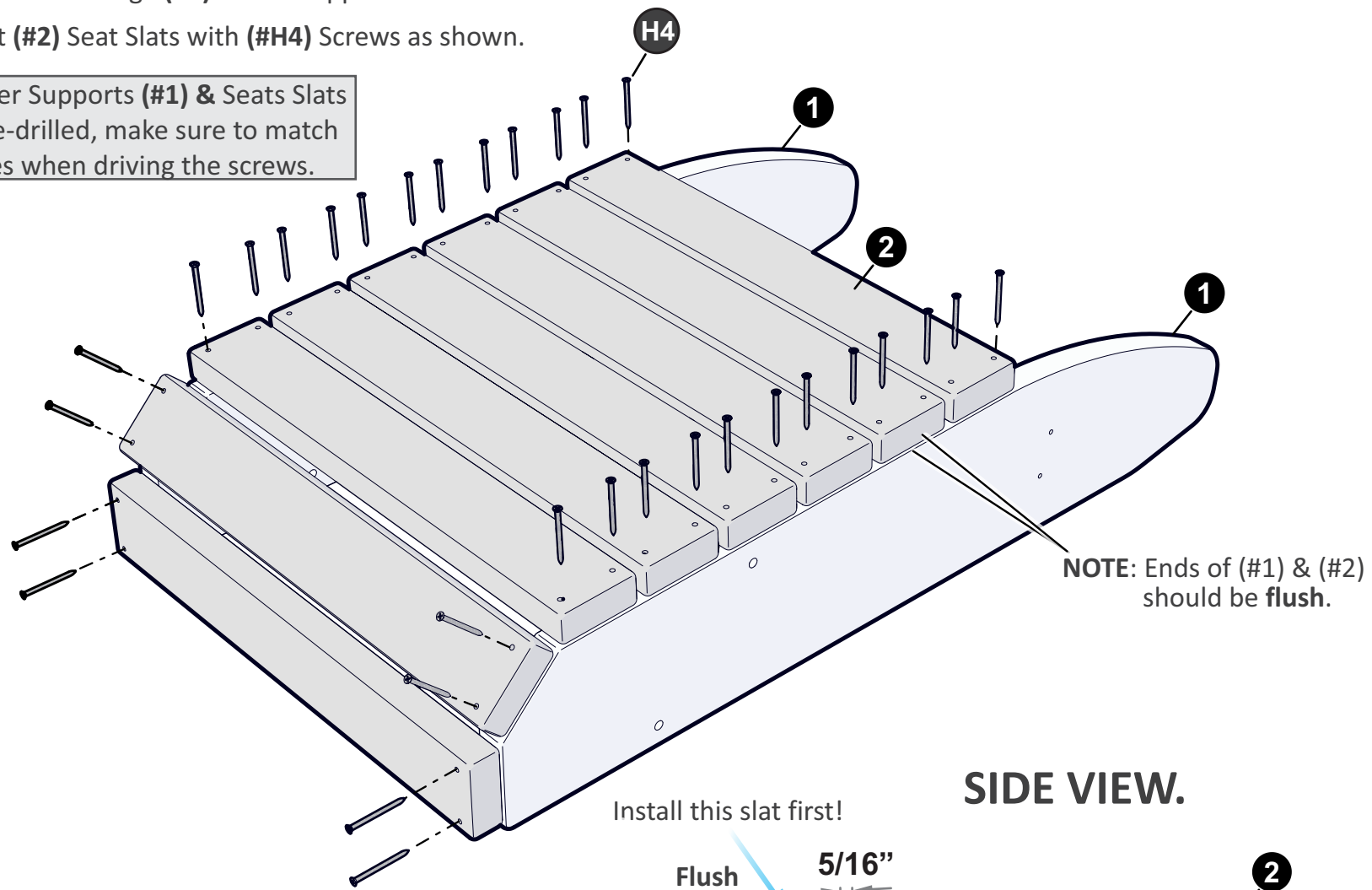

**SIDE VIEW.**

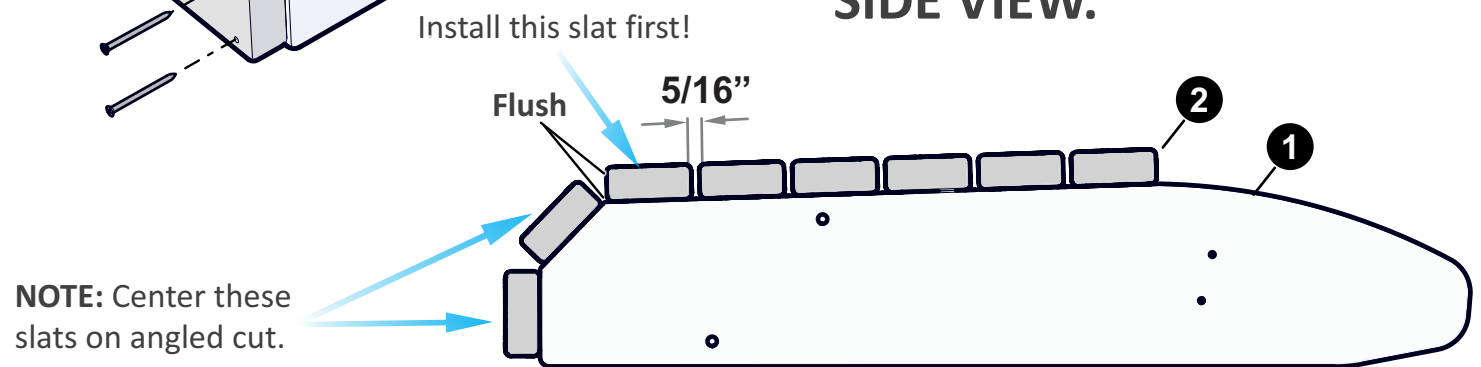

### STEP 3

Flip seat assembly over and attach (#4) Arm Supports as shown. Use (#H1) Carriage Bolt, (#H3) Washer & (#H2) Nut to attach to the seat assembly.

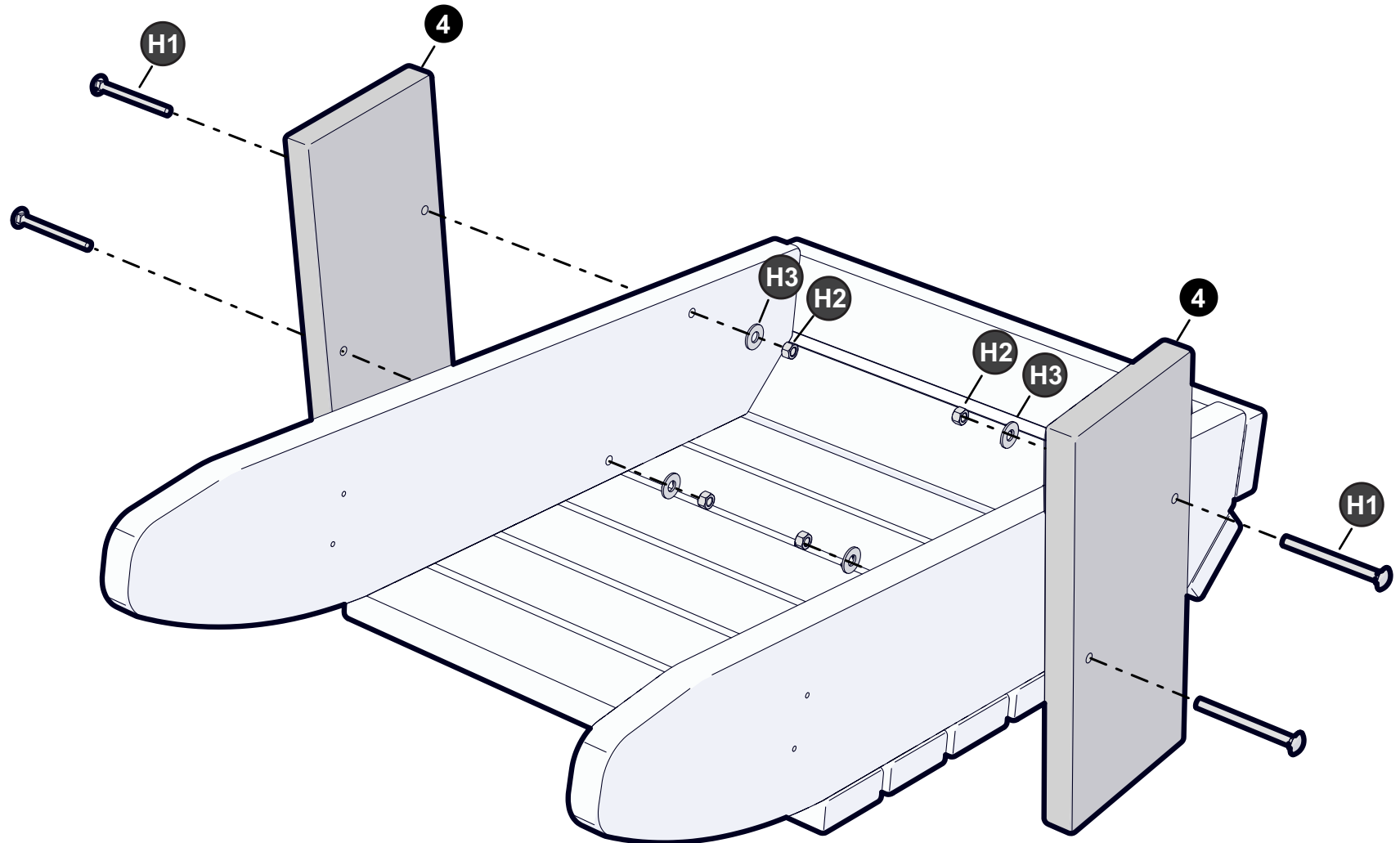

## STEP 4

Flip the seat assembly over and attach the back assembly as shown. Match the pre-drilled holes on the bottom Back assembly Board.

**NOTE:** Only install the **top** screw on each side of the assembly. The bottom screw will be installed in a later step.

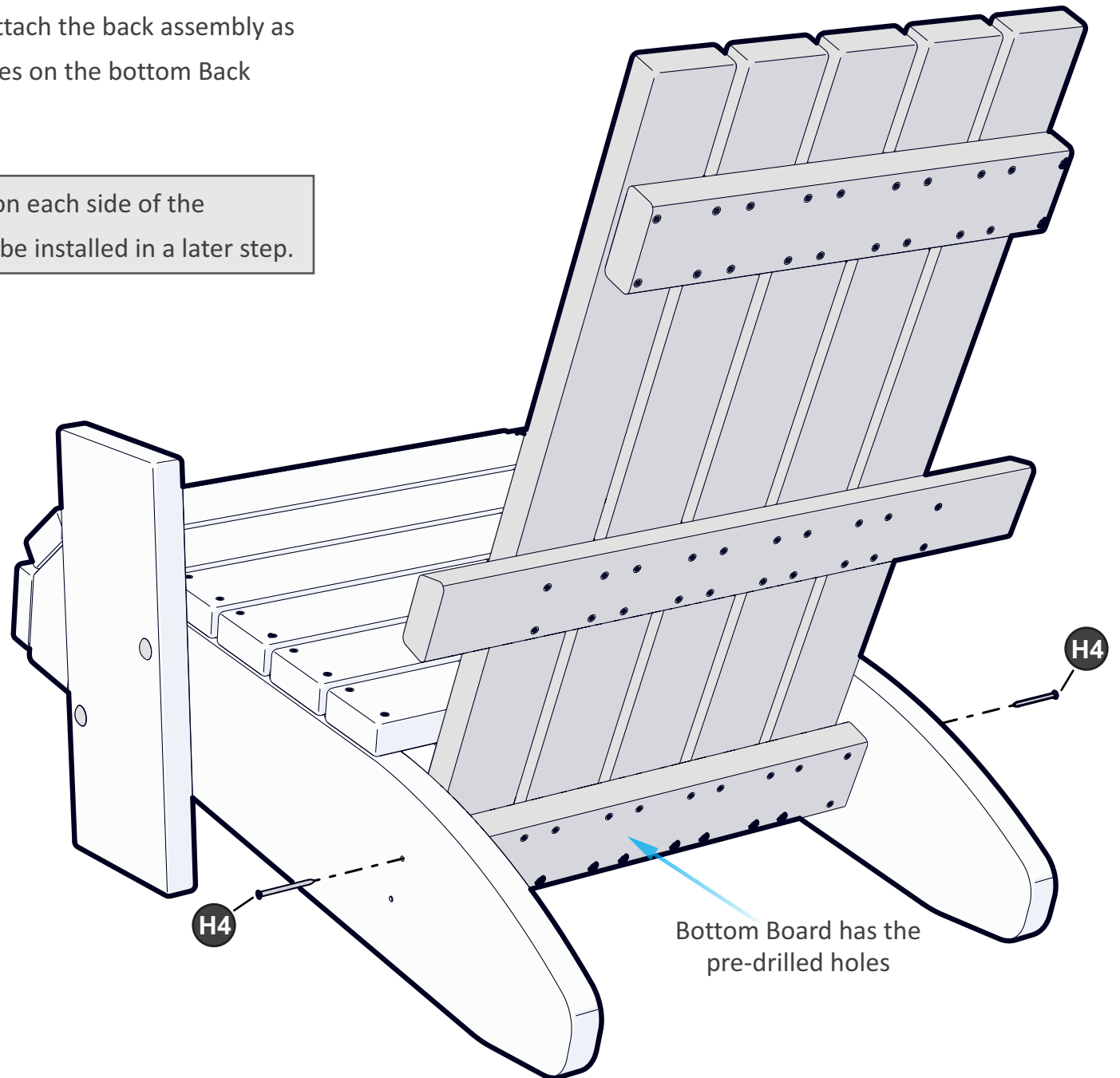



## STEP 5

Center and attach (#3) Arms with (#H4) Screws as shown.

**NOTE:** All H4 screws must be centered on the Arm Supports as shown in the illustrations.

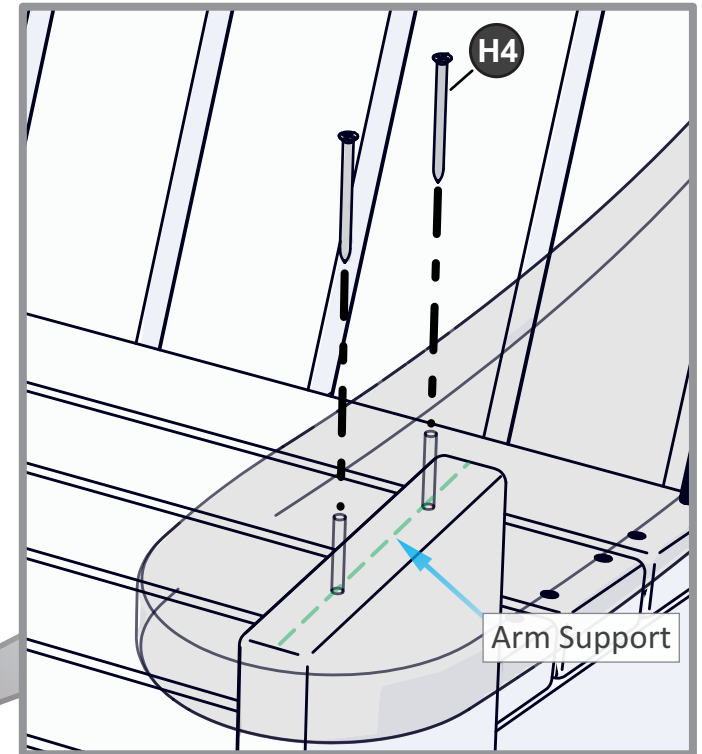
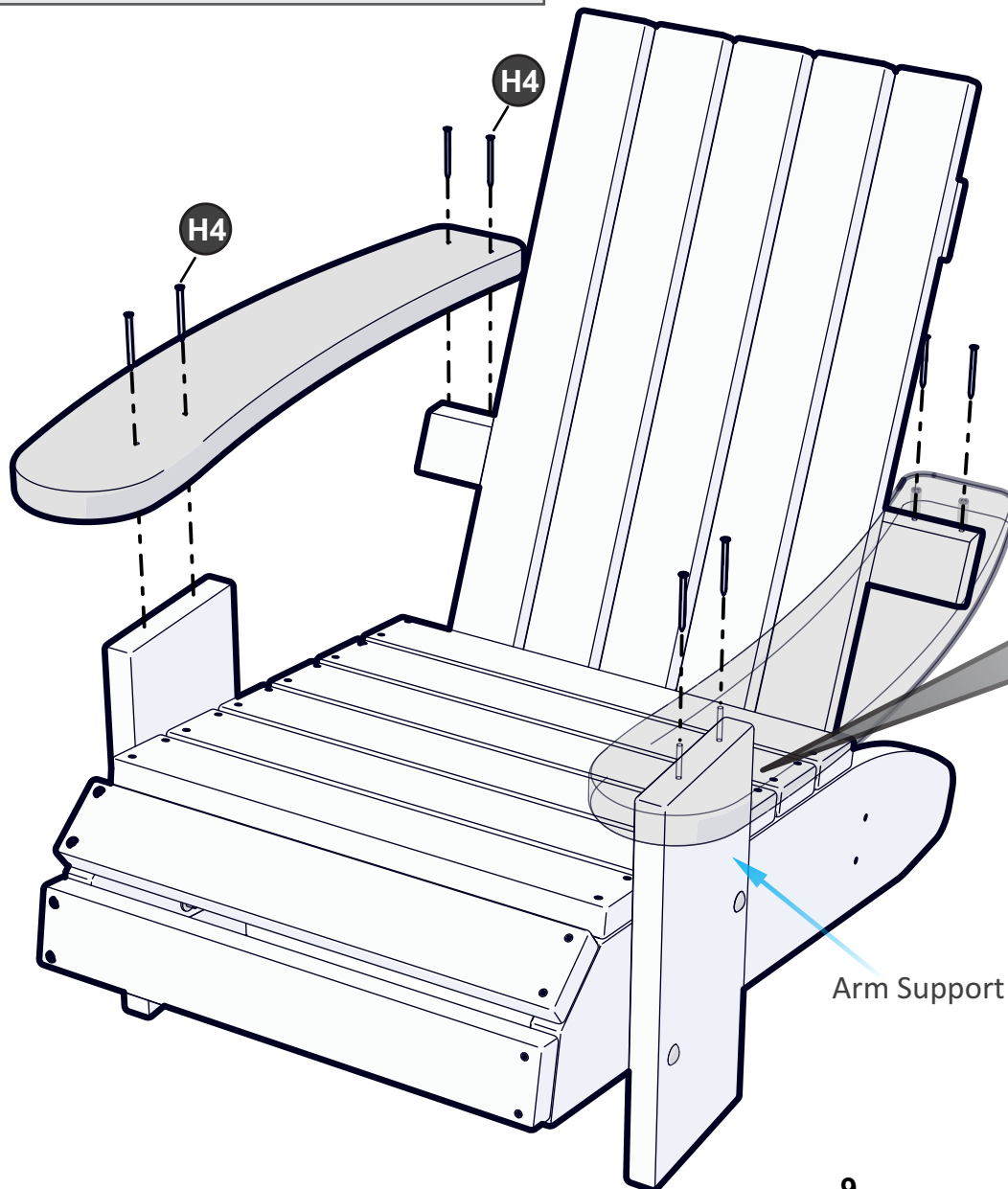

**NOTE:** H4 screws must be centered on the Arm Supports as shown.

## STEP 6

Match the pre-drilled holes on the bottom Back assembly Board and attach screws (#H4) the bottom holes as shown.

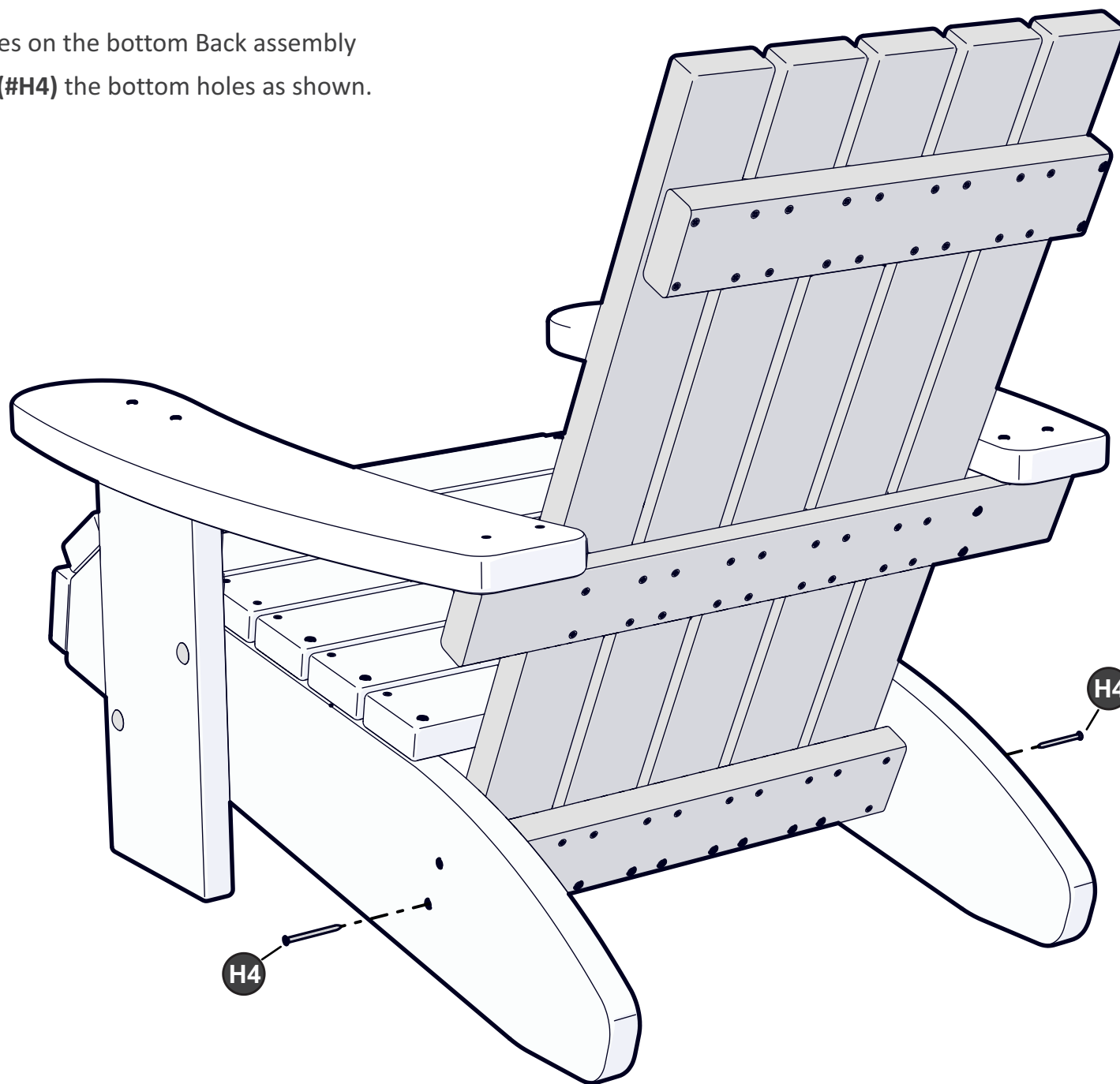

# JACK & JUNE WARRANTY

## **1 Year Warranty**

Subject to proper installation and normal residential use, Jack & June warrants, subject to the limitations stated below, to the original retail purchaser, parts to be free from defects in material and workmanship for a period of **one year** from date of purchase. Merchandise covered under this limited **one-year** warranty will, at our option, be repaired or replaced, excluding any freight or labor fees.

For **one Year** after the original purchase date of our **products**, Jack & June warrants, to the original retail purchaser, all wooden components against structural failure due to corrosion, wood rot, or insect infestation. Seasonal checks, surface cracks, knotholes and knots, not resulting in structural failure, are natural characteristics of all wooden play equipment, are not covered under this warranty and will not affect the integrity of your playset.

Jack & June warrants to the original retail customer that we will replace any hardware that fail due to rust or breakage (excludes surface rust).

Timber is a natural material which can absorb and release moisture. Although this product is designed to minimize this effect, in certain circumstances some movement or distortion is unavoidable. During dry hot weather timber may shrink and check - this is a normal process of weathering. After the first year of service it is advisable to clean and apply a non-toxic stain or sealant to the wood, safe for children's use.

Components covered under this **1 year** warranty will be replaced free of charge excluding freight and labor fees.

Non-residential use of the playset is prohibited and voids the warranty as the playsets are designed for residential use only.

Escalade Sports reserves the right to examine photographs and/or physical evidence of merchandise claimed to be defective, and to recover said merchandise, prior to disposition of warranty claims. Merchandise returned to our factory for examination or recovery must be shipped freight prepaid, unless a Return Authorization Number is issued.

This warranty program does not cover normal wear and tear, color fading, or damages resulting from misuse, abuse, vandalism, alteration, acts of God, or assembly and maintenance contrary to our instructions. Escalade Sports assumes no responsibility for incidental or consequential damages which may arise from the purchase or use of our equipment. Please supervise your children's play activity and maintain your play equipment periodically.

This warranty is expressly in lieu of all other warranties, expressed or implied, including warranties of merchantability or fitness for use. Jack & June does not assume or authorize any person to assume for us, any other liability in connection with the sale of our products.

Special Note: Jack & June reserves the right to make changes in materials, design, and pricing without notice. See your instruction manual for maintenance requirements. Your child's safety is your responsibility; therefore, you should inspect this equipment regularly for wear and safety.

**For warranty service, contact:**

**Escalade Sports**

**P.O. Box 889**

**Evansville, IN 47706**

**1-800-GO-SWING**

**Or E-Mail us at: [playgroundcs@escaladesports.com](mailto:playgroundcs@escaladesports.com)**