

- NOTES: UNLESS OTHERWISE SPECIFIED
1. FOR GENERAL SERIES SPECIFICATIONS, SEE SD74-0000.
 2. MATERIAL SPECIFICATIONS: BRASS PER ASTM B16.
 3. FINISH SPECIFICATIONS:
 BODY: .000030 MIN GOLD PER ASTM B488 OVER
 .000050 MIN NICKEL PER AMS-QQ-N-290
 4. ELECTRICAL SPECIFICATIONS:
 CURRENT RATING: 30 AMP
 5. FOR USE WITH 10 GA. OR EQUIVALENT WIRE.
 6. REFER TO CAP10-01 FOR CABLE ASSEMBLY PROCEDURE.

REV	DESCRIPTION	BY DATE	APPD
C	REVISED PER ER7306	04/14/08 CWB	CWB

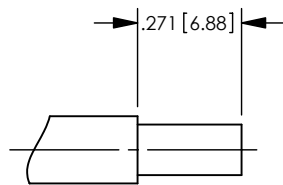
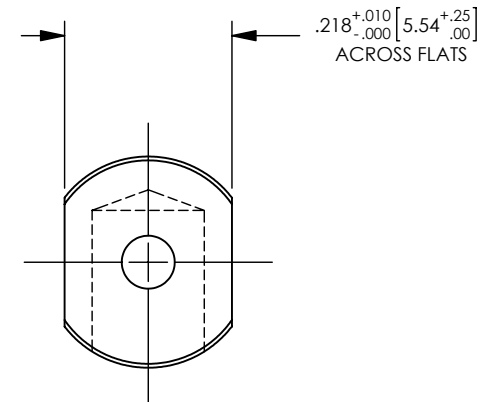
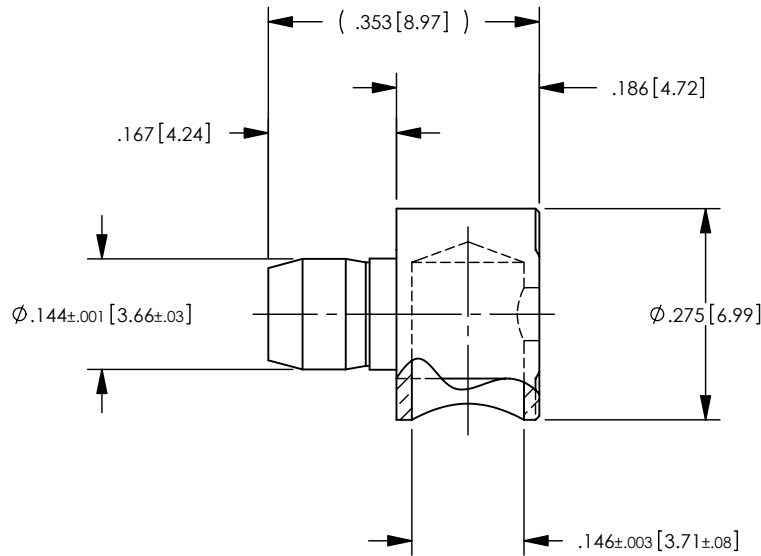

RECOMMENDED CABLE TRIM DIMENSIONS
 SCALE: 2:1

CATALOG P/N: 01361

PER ASME Y14.5M-1994 UNLESS OTHERWISE SPECIFIED: DIMENSIONS ARE IN INCHES [MM] TOLERANCES: DECIMAL: XX [X.X] \pm .01 [0.3] XXX [X.XX] \pm .005 [0.13] ANGLES: $\pm 2^\circ$ SCALE: 4:1				 Winchester Electronics Corporation 62 Barnes Industrial Road North Wallingford, Connecticut 06492	
CUSTOMER DRAWING					
DRAWN JEM	DATE 10/15/03	APPROVED CWB	DATE 10/15/03	POWER SNAP RIGHT ANGLE SOLDER MOUNT 10 AWG, 30 AMP	
APPROVED JED	DATE 10/15/03	APPROVED SD	DATE 10/15/03	A	SD01361
				SHT 1 OF 1	REV C