

Multi-Flash #2 • 7/8 - 4 inch (Retrofit: 1/2 - 3 1/2 inch) • Black EPDM Rubber with Stainless Steel Gripper

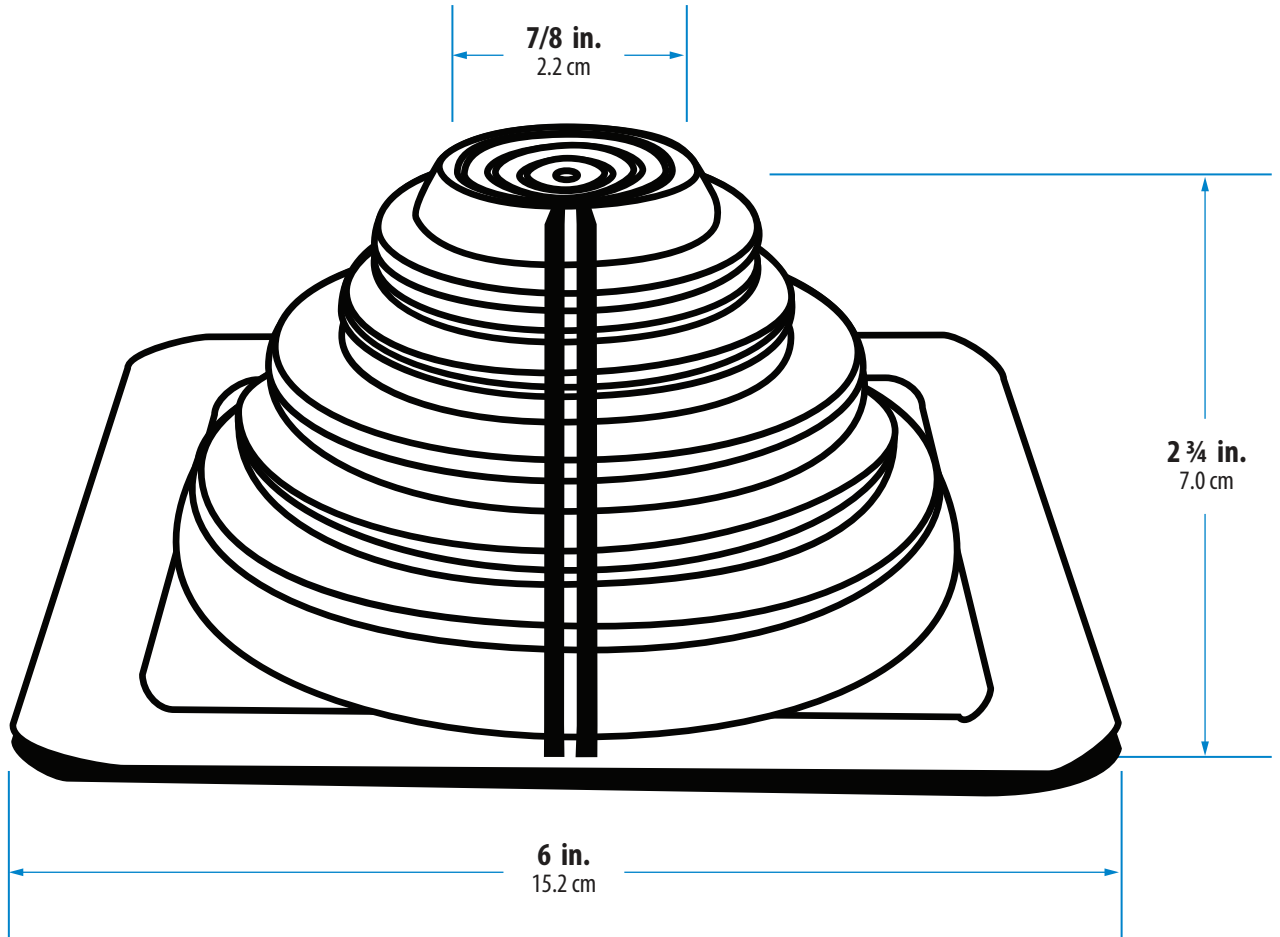

COMPOUND & SPECIFICATION DATA FOR BLACK EPDM

TYPICAL PHYSICAL PROPERTIES OF EPDM - ASTM D2000 M3BA510 A14, B13, C12, F17, Z1, Z2, Z3, Z4, Z5

Property	Value	Test Method	
A14	Heat Aging	70 hrs. @ 100° C	ASTM D573
B13	Compression Test	22 hrs @ 70° C Max. 25%	ASTM D395 B
C12	Ozone Resistance	70 hrs. @ 50 pphm	ASTM D1171
F17	Low Temp. Brittleness	3 Minutes @ -40° C PASS	ASTM D2137A, 9.3.2
Z1	Target Hardness	55 +/-5 Shore A	ASTM 2240
Z2	Specific Rubber	EDPM	PASS
Z3	Horizontal Flame Resistance	Not to exceed 3 in./minute	ASTM 2240