

## CONTENTS

- 02 Side Frame
- 20 Supporting Cross Bars
- 40 Bolts [5/16" x 1-5/8"]
- 40 Lock Washers [5/16"]
- 40 Flat Washers [5/16"]
- 09 Base Shelves

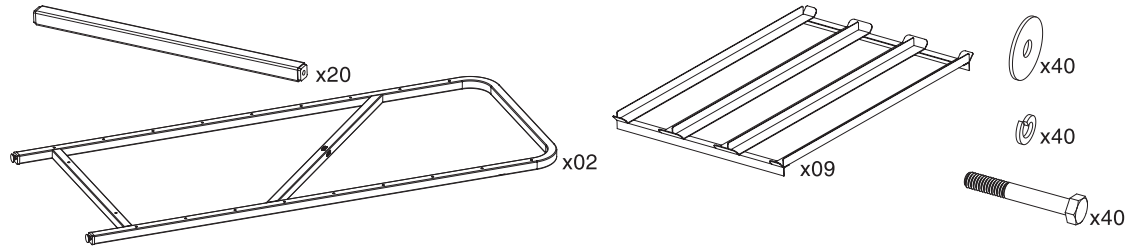

\*Contents are not to scale to each other

## 1 ASSEMBLE THE RACK

- Preassemble the provided hardware:
  - >> Insert a bolt into lock washer and flat washer.
- Align the cross bar hole with the side frame hole and secure with bolt/washer assembly by hand tightening.
  - >> Repeat for the other bars on both side racks.
- Align the remaining side frame to the cross bars and secure with bolt/washer assembly by hand tightening.

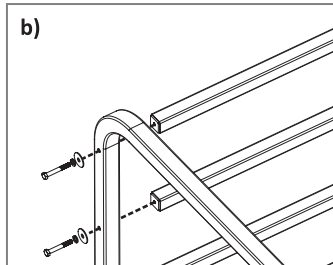
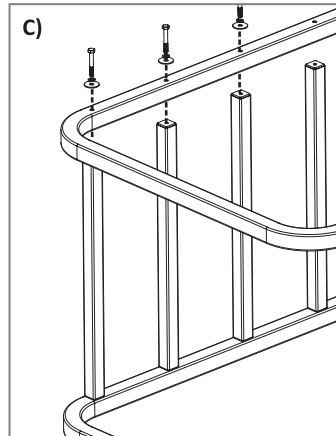
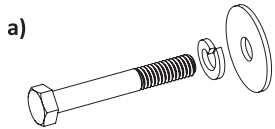

**NOTE:**  
Make sure cross bars  
have flat side facing up.



## 2 INSTALL RACK SHELVES

- Stand rack upright on a level surface/floor.
- Place the rack shelves onto the support bars.

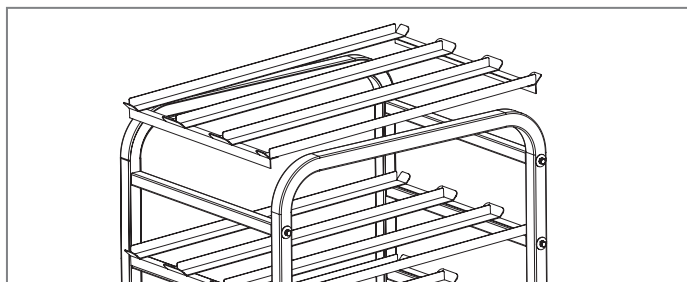

## 3 ADJUST LEVELERS

- Adjust levelers on the bottom of rack.

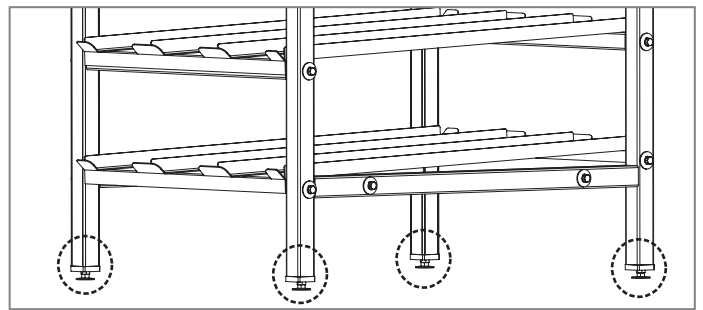

## 4 FINAL CHECK

- Stand the rack upright on a level surface/floor.
- All levelers must be touching the floor evenly.
- Firmly tighten all bolts to ensure they are secure.

**CAUTION**

**DO NOT  
OVERTIGHTEN  
BOLTS .**

Overtightening may  
cause stripped  
threads and  
the bolt will not  
function properly.

