



**IMPORTANT**

Carefully remove all the parts from the carton and place them individually on a soft cloth to prevent scratches or other damage.

Carefully and strictly follow these assembly instructions to ensure a completed product as designed.

Do not use power tools above 8 volts to assemble.

**Part List**

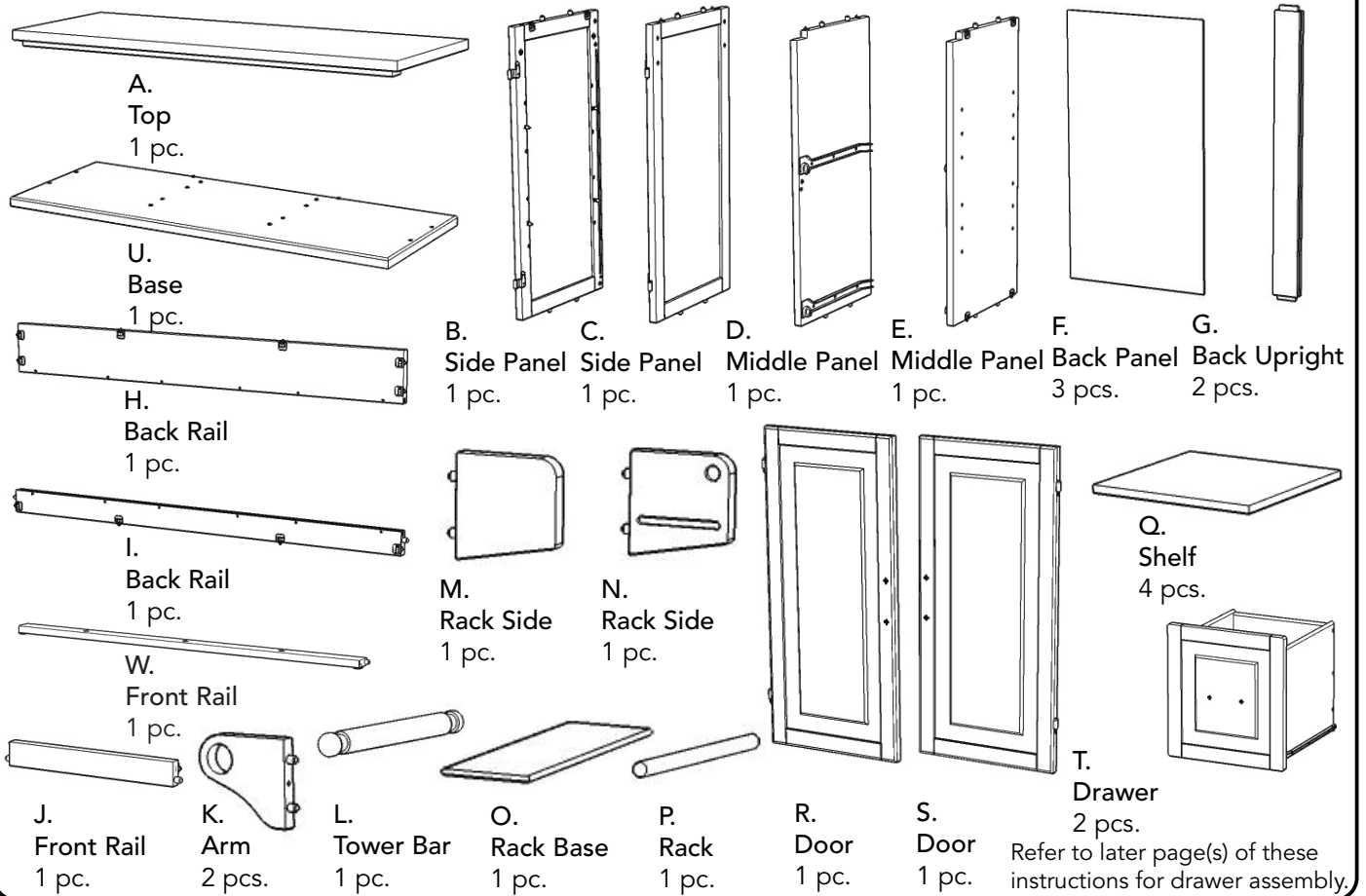

**Hardware List**

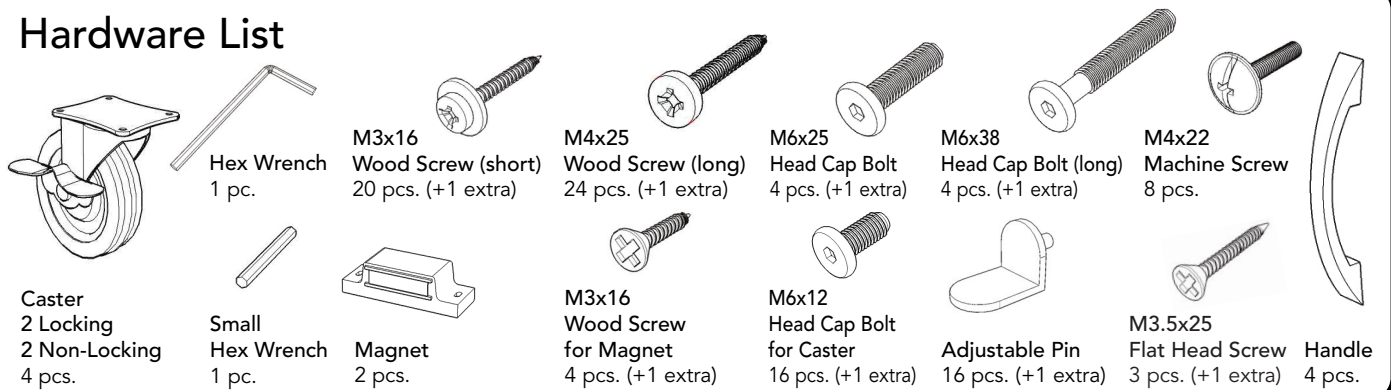

Tool(s) required for assembly: Phillips screwdriver

Home Styles Customer Service: [www.homestylesfurniture.com](http://www.homestylesfurniture.com),  
servicedesk@homestylesfurniture.com, 888-680-7460, 877-831-0319

## Assembly Instructions 2/7

### IMPORTANT

- Use a soft cloth between these parts and the floor.
- Do not use power tools above 8 volts to assemble.
- Do not tighten all the bolts until each part is properly assembled.
- Keep Hex Wrench as the bolts may need to be tightened in the future.

### STEP 1

Assemble Rack Sides (M), (N), Rack Base (O) and Rack (P).

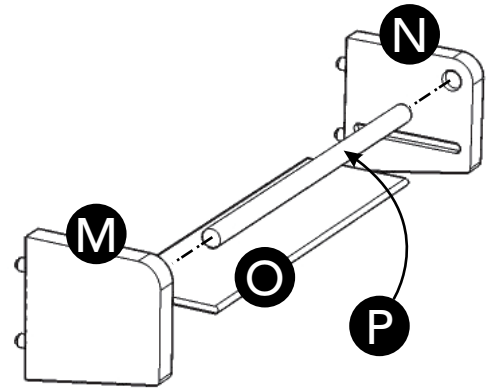

### STEP 2

Attach unit to Side Panel (C) with Head Cap Bolts.

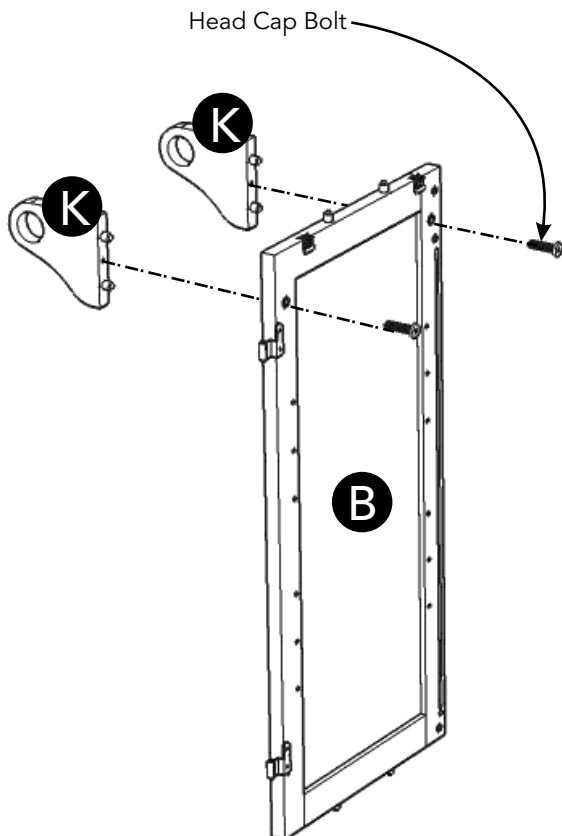
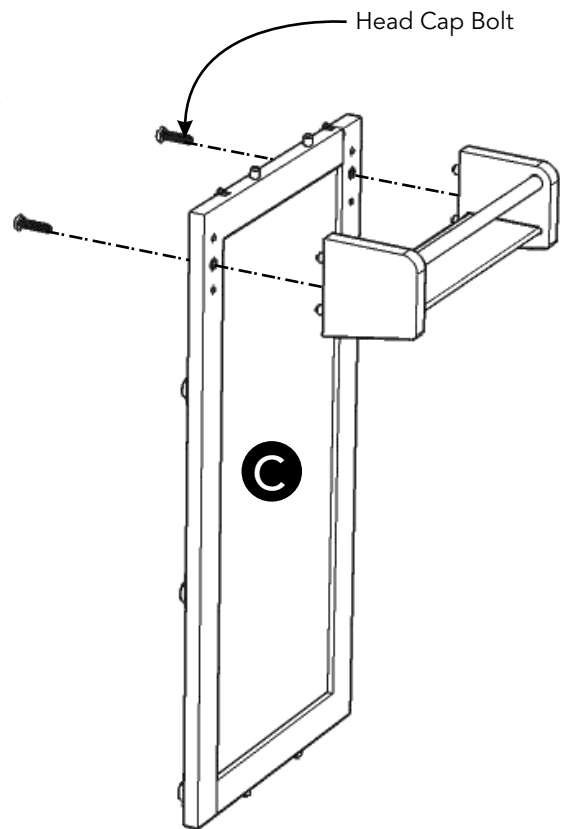

### STEP 3

Attach Arms (K) to Side Panel (B) with Head Cap Bolts.

## Assembly Instructions 3/7

### STEP 4

Attach Back Rail (H) to Side Panel (C), then flip Locks.  
(See Figures 1 and 2)

Attach Back Uprights (G) to unit.

Slide Back Panels (F) into position.

Attach Back Rail (I) to unit, then flip Lock.

Attach Side Panel (B) to unit, then flip Locks.

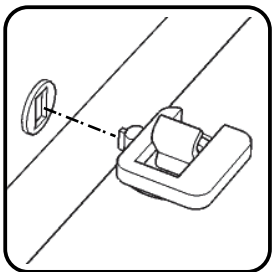
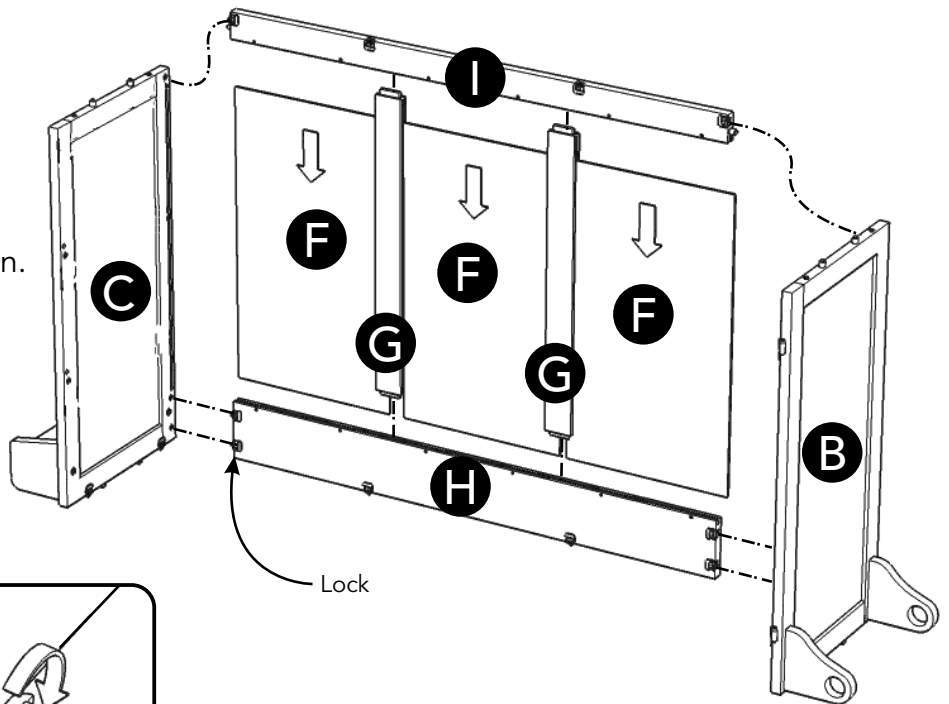

Figure 1

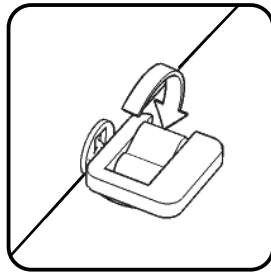
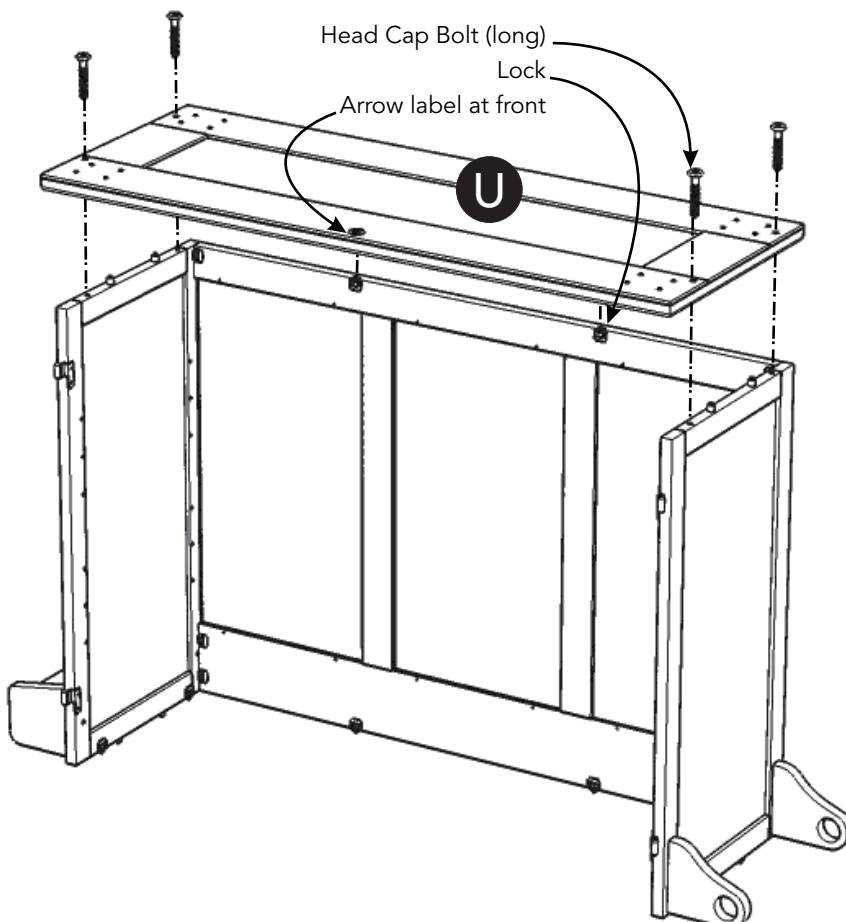

Figure 2



### STEP 5

Attach Base (U) to unit with Head Cap Bolts (long), then flip Locks.  
(See Figure 3)

Note: Arrow label indicates front of Base (U).

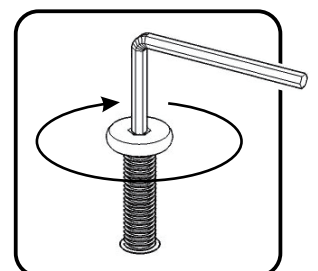

Figure 3

# Assembly Instructions 4/7

## STEP 6

Attach Casters to unit with Head Cap Bolts for Caster into pre-drilled holes, with Locking Casters at front. (See Figure 4)

Note: Arrow label indicates front of unit.

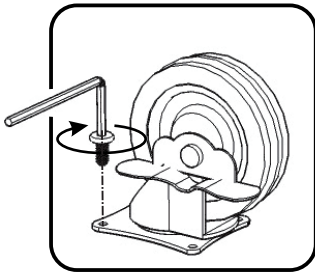
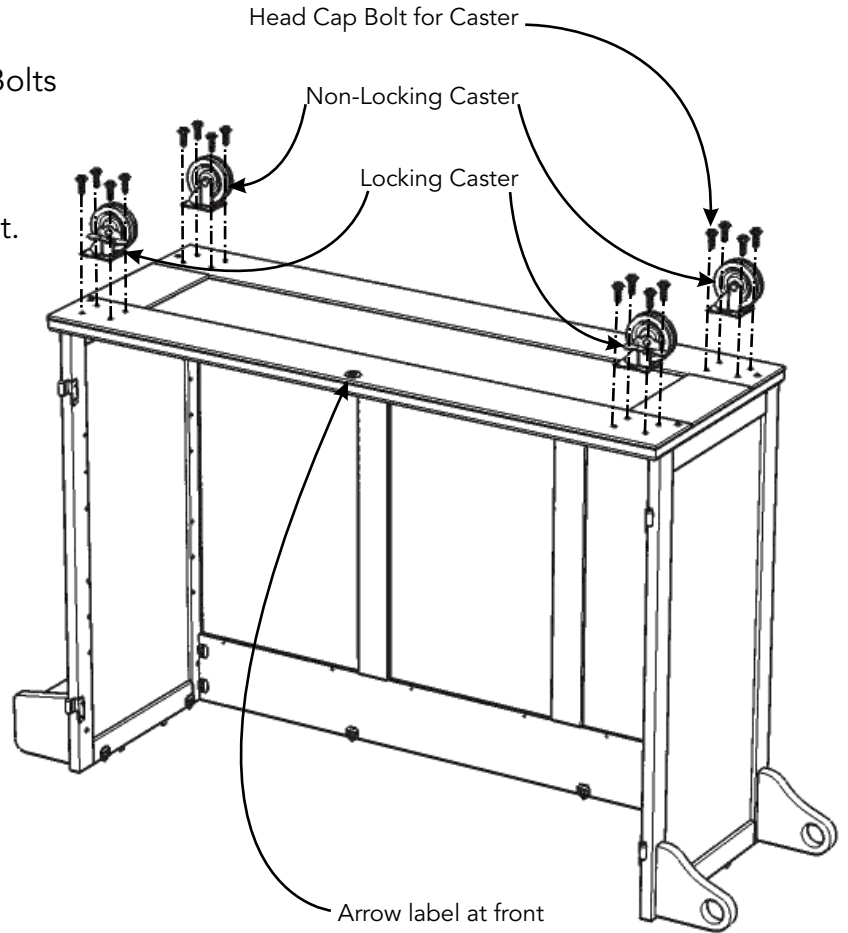
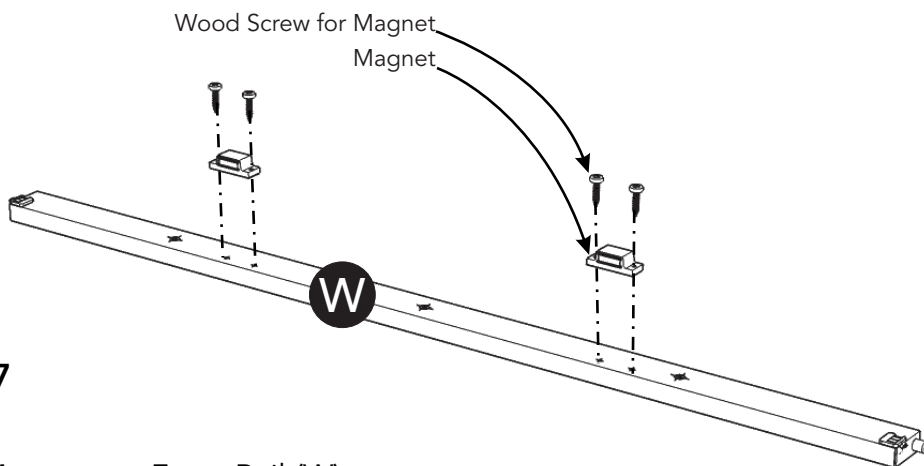

Figure 4



## STEP 7

Attach Magnets to Front Rail (W) by inserting Wood Screws for Magnet into pre-drilled holes, then tighten. (See Figure 5)

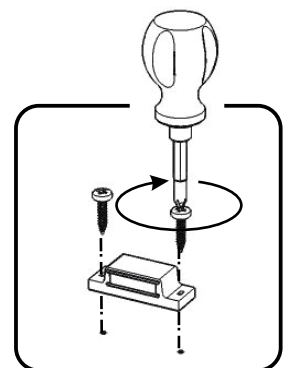

Figure 5

## Assembly Instructions 5/7

### STEP 8

Turn unit over to its upright position.

Attach Middle Panel (D) to unit, then flip Locks.

Attach Front Rail (J) and Middle Panel (E) to unit, then flip Lock.

Insert Wood Screws (short) into pre-drilled holes in unit, then tighten.

Slide Towel Bar (L) into position.

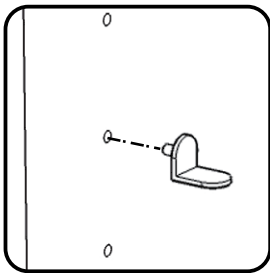
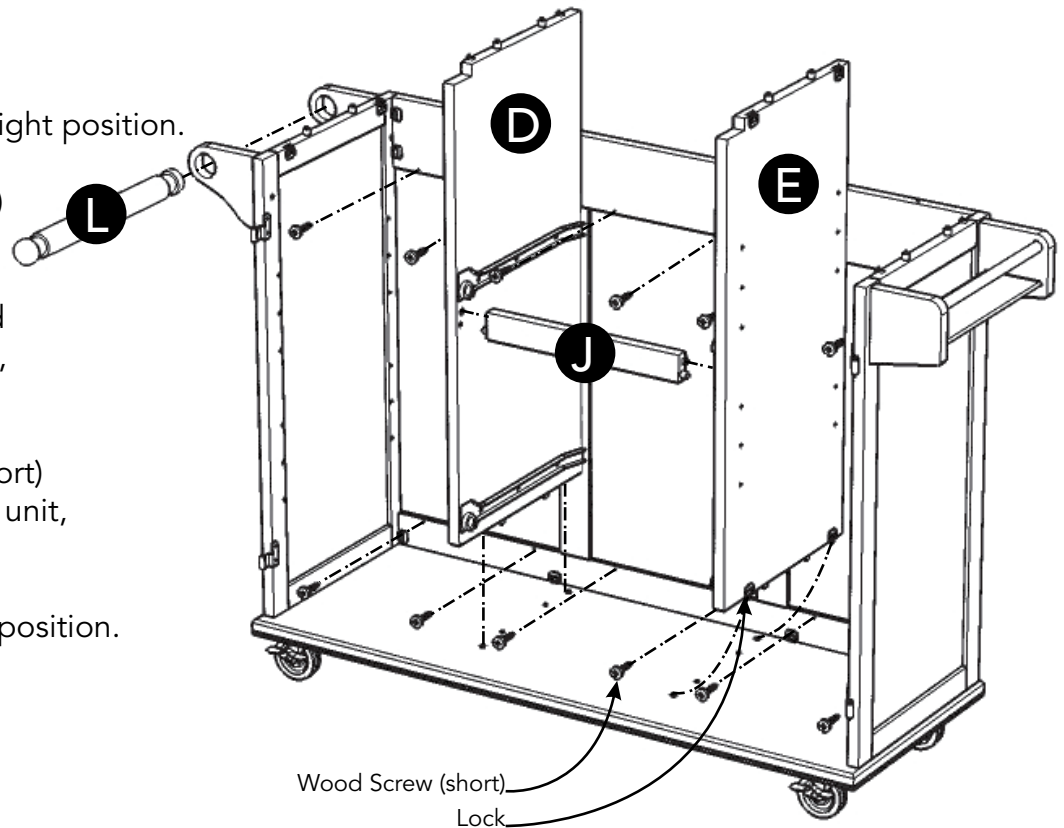

Figure 6

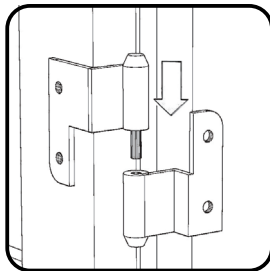
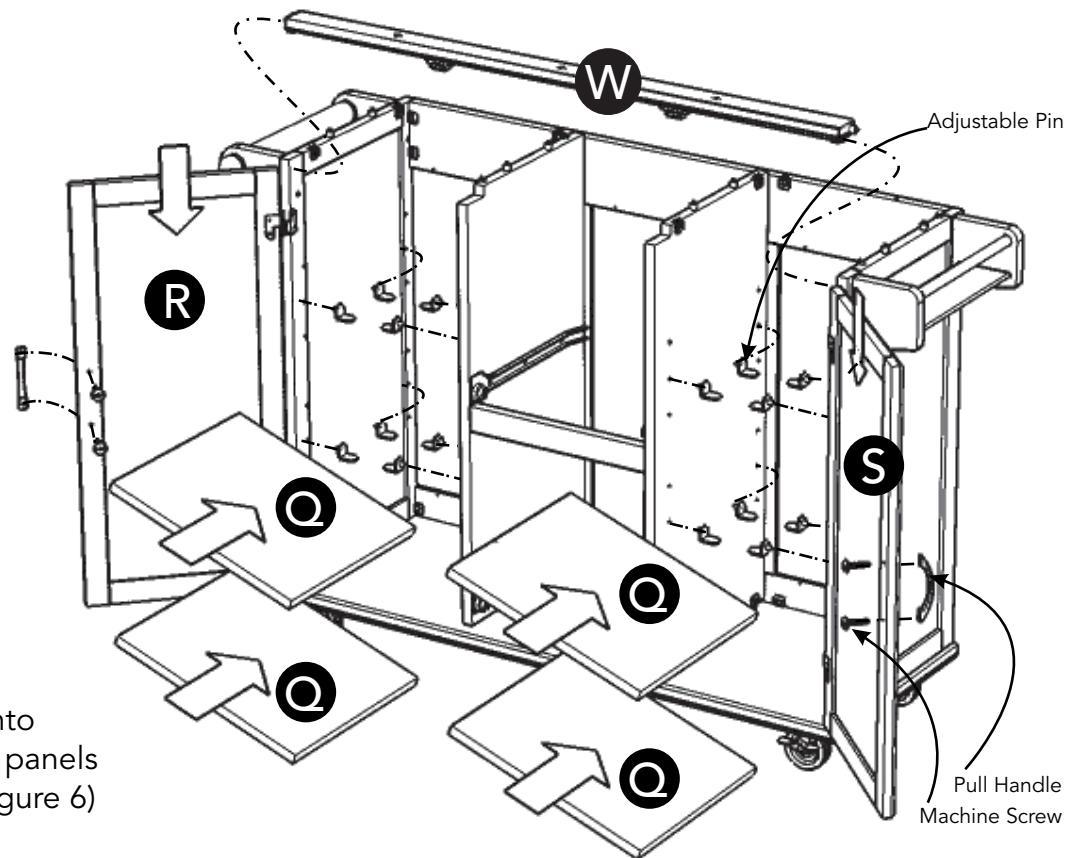

Figure 7



### STEP 9

Insert Adjustable Pins into side panels and middle panels at desired level. (See Figure 6)

Place Shelves (Q) into position.

Attach Doors (R) and (S) by sliding door hinges into side panel hinges. (See Figure 7)

Attach Handles to Doors (R) and (S) with Machine Screws.

Attach Front Rail (W) to unit, then flip Locks.

# Assembly Instructions 6/7

## Drawer (T)

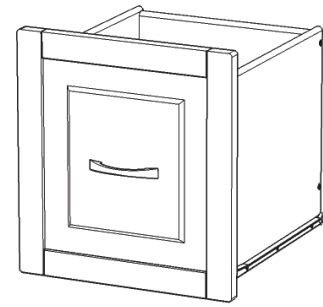
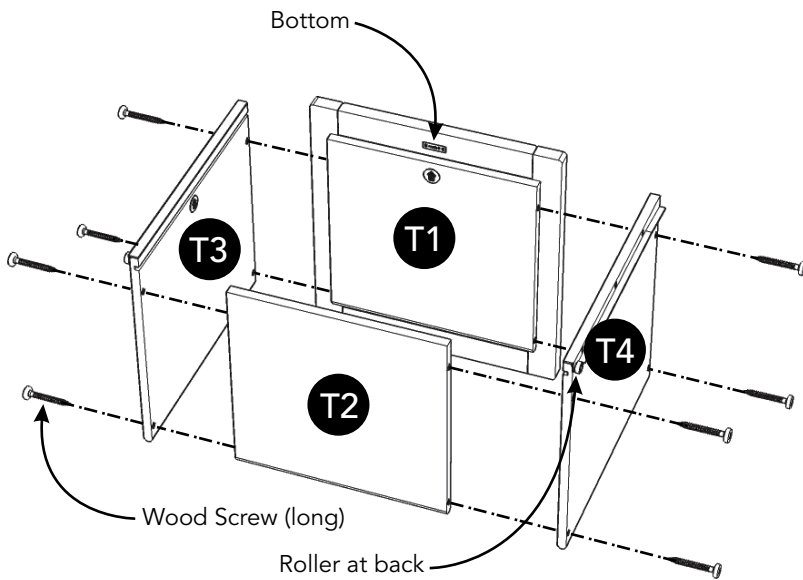

### STEP 10

Attach Drawer Front (T1) and Drawer Back (T2) to Drawer Side (T3) with Wood Screws (long).

Attach Drawer Side (T4) to unit with Wood Screws (long).

### STEP 11

Slide Drawer Bottom (T5) into groove.

Attach Drawer Bottom (T5) to unit with Wood Screws (short).

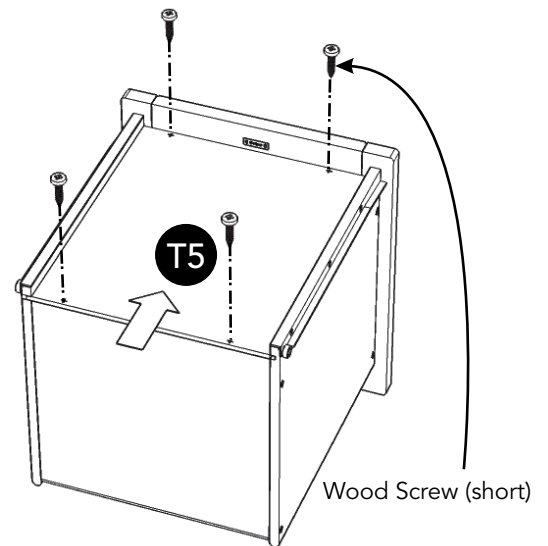
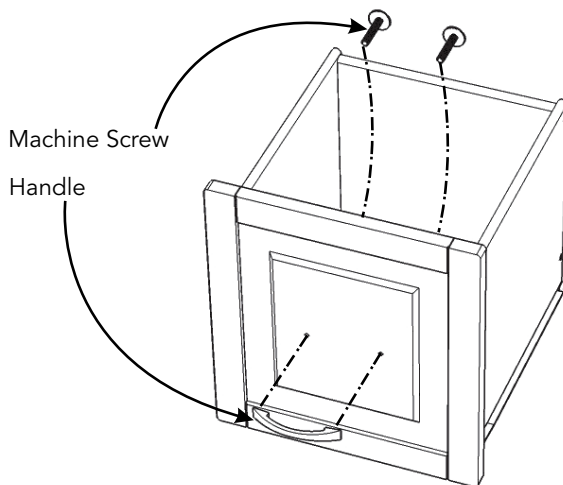

### STEP 12

Attach Handle with Machine Screws.

## Part List

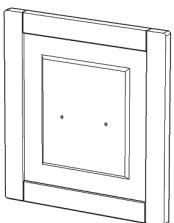

T1.  
Drawer Front  
2 pcs.

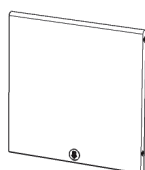

T2.  
Drawer Back  
2 pcs.

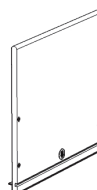

T3.  
Drawer Side  
2 pcs.



T4.  
Drawer Side  
2 pcs.

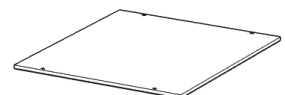

T5.  
Drawer Bottom  
2 pcs.

## Assembly Instructions 7/7

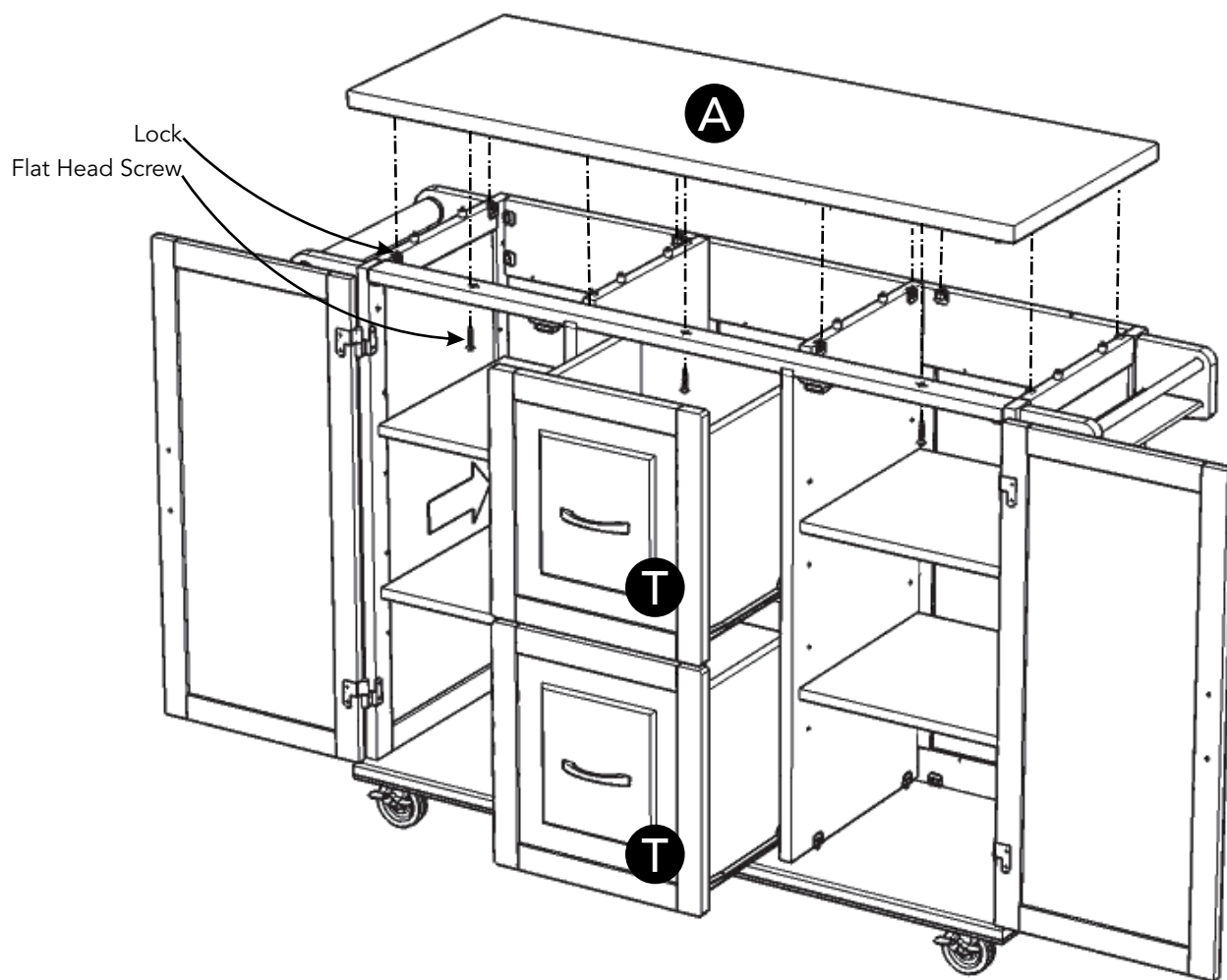

### STEP 13

Attach Top (A) to unit with Flat Head Screws, then flip Locks.

Slide Drawers (T) into position.

# CARE INSTRUCTIONS

## NEVER

allow liquids to remain on furniture.  
Absorption causes parts to warp  
and split and finishes to delaminate.

## NEVER

use glass cleaners on  
finished furniture. Ammonia  
chemically attacks the finish.



Do not use power tools  
above 8 volts to assemble.

**PREVENT  
CRACKING**

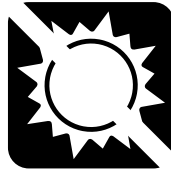

Do not place  
in direct sunlight.

**PREVENT  
FADING**



Do not write  
directly on surface.

**PREVENT  
MARKING**



Do not place hot  
objects on surface.

**PREVENT  
FINISH DAMAGE**

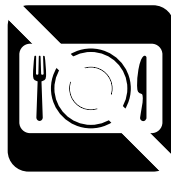

Do not use rubber  
based placemats.

**PREVENT  
DISCOLORING**



Do not use commercial  
waxes and polishes.

**PREVENT  
YELLOWING**

## CLEAN

with a soft cloth moistened  
in lukewarm soap and water.  
Buff with a dry clean cloth.



Home Styles will provide replacements free of charge for missing or damaged hardware or parts within 30 days of purchase. Digital images of the defective parts may be required. If the product was not purchased from an authorized retail affiliate, Home Styles is under no obligation to provide replacement parts. Parts are not available for fully assembled items nor are parts available for sale. Replacements for missing or damaged hardware or parts may be requested at:

[www.homestylesfurniture.com/customer-service/replacement-parts](http://www.homestylesfurniture.com/customer-service/replacement-parts)

Home Styles Customer Service: [www.homestylesfurniture.com](http://www.homestylesfurniture.com),  
[servicedesk@homestylesfurniture.com](mailto:servicedesk@homestylesfurniture.com), 888-680-7460, 877-831-0319