

# INSTRUCTION MANUAL

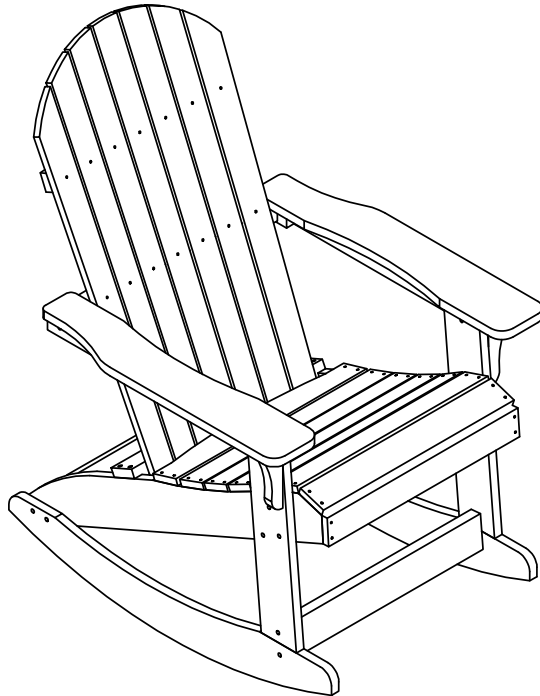

**Outdoor Rocking Adirondack Chair**  
**SKU: OP5004**

**V1.0**

## ! NOTICE

### Do not overtighten screws. (Insert all screws before tighten screws.)

- Please do not exceed the weight limitations of this item.
- Do not stand on or use any part of this item as a step ladder.
- Firmly secure all bolts, screws and nuts before use.
- Reconfirm that all bolts, screws, and nuts are secure every 90 days.
- Do not use or store this item in the proximity of open flame or flammable/combustible chemicals.
- Be aware that some parts are heavy and have sharp edges.
- Please adjust the speed slowly when you use electric drill for assembling to avoid screw slippage.

## TOOLS REQUIRED



SCREWDRIVER  
(PROVIDED)



ALLEN WRENCH  
(PROVIDED)



CHAIR  
330 LBS  
CAPACITY



1 PERSON  
ASSEMBLY



UP TO 30 MIN.  
ASSEMBLY

## HARDWARE

1

M4 x 40mm  
SCREW



4 PCS

2

M6 x 40mm  
BOLT



4 PCS

3

M6 x 55mm  
BOLT



6 PCS

4

M6 x 60mm  
BOLT



8 PCS

5

M6 x 80mm  
BOLT

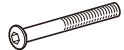

2 PCS

6

M6 x 90mm  
BOLT

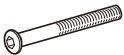

2 PCS

7

FLANGE NUT



10 PCS

8

ALLEN  
WRENCH



1 PC

9

SCREWDRIVER

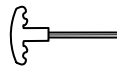

1 PC

## PARTS

A

CHAIR BACKREST

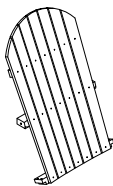

1 PC

B

CHAIR SEAT

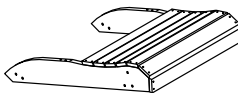

1 PC

C

RIGHT CHAIR ARM



1 PC

# PARTS

**D**

LEFT CHAIR ARM

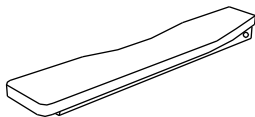

1 PC

**E**

RIGHT CHAIR LEG

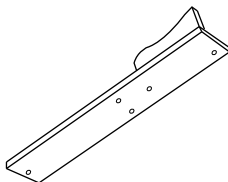

1 PC

**F**

LEFT CHAIR LEG

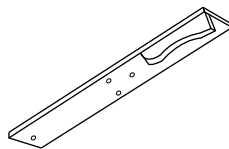

1 PC

**G**

REAR BRACE

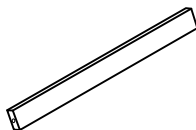

1 PC

**H**

REAR SLAT

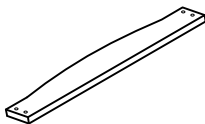

1 PC

**J**

ROCKING BASE

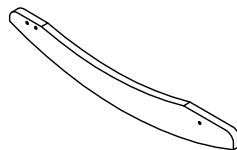

2 PCS

**K**

FRONT BRACE

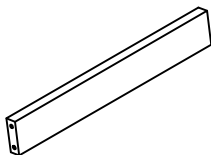

1 PC

## PRODUCT ASSEMBLY - OVERALL VIEW

Look at the overall view of this chair and learn the exact position of each part to be assembled.

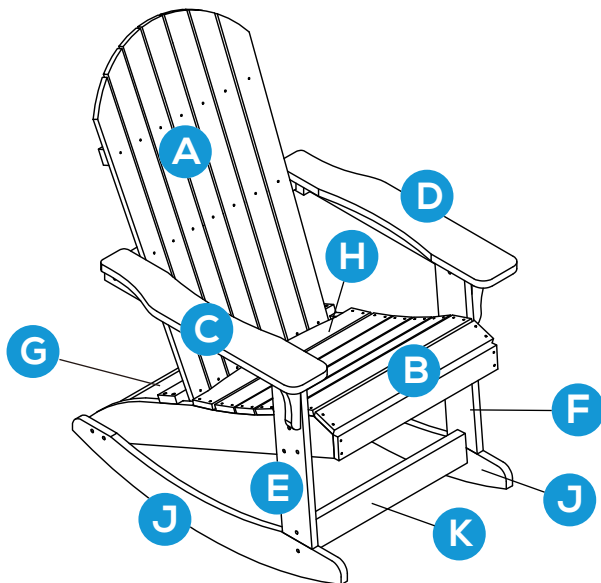

## PRODUCT ASSEMBLY

**1**

Place part H Rear Slat onto part B Chair Seat as below, attach the rear slat with 4 pcs of hardware 1 Screw.

Attention: Keep countersink holes facing upward and put screws in.

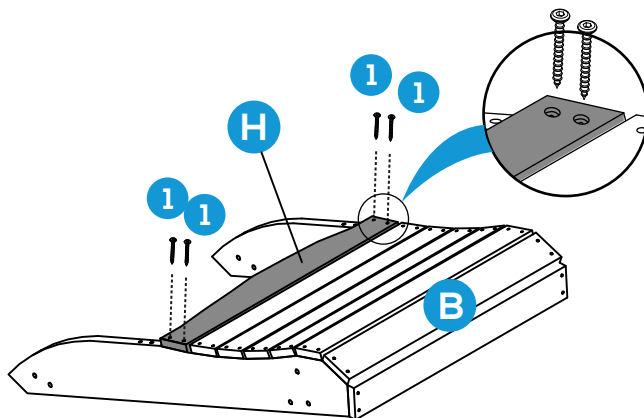

## PRODUCT ASSEMBLY

2

Attach part E Right Chair Leg to combined part ( B + H ) Chair Seat with 3 sets of hardware 4 Bolt and hardware 7 Flange Nut,

Do the same to attach part F Left Chair Leg to combined part ( B + H ).

Do not tighten bolts too much at this stage.

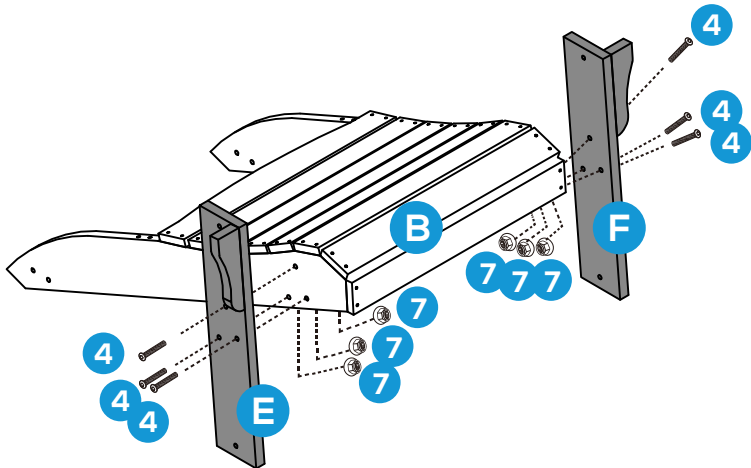

3

Place the assembled body (Chair Seat + Legs) onto part J Rocking base as below.

Place part K Front brace between two legs and rocking bases, attach them with 4 pcs of hardware 3 Bolt as below.

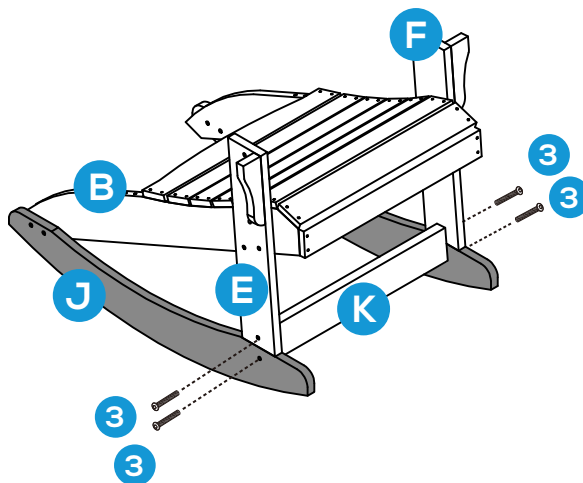

## PRODUCT ASSEMBLY

4

Attach 2 pcs of part J Rocking Base to part B Chair Seat with 2 sets of hardware 5 Bolt and hardware 7 Flange Nut.

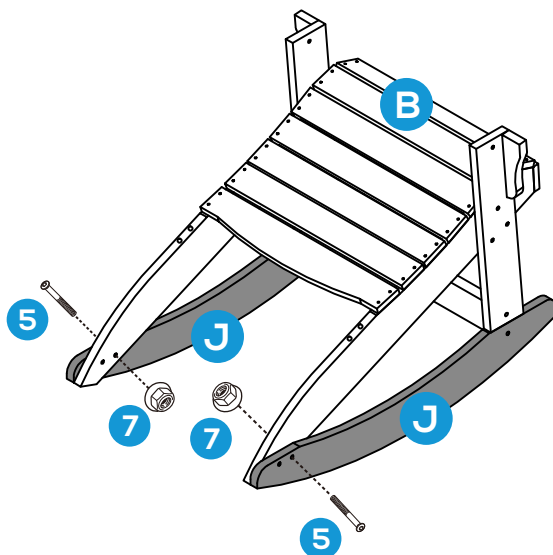

5

Place part G Rear Brace between rear part of part B Chair Seat as well as part J Rocking base, attach them with 2 pcs of hardware 3 Bolt.

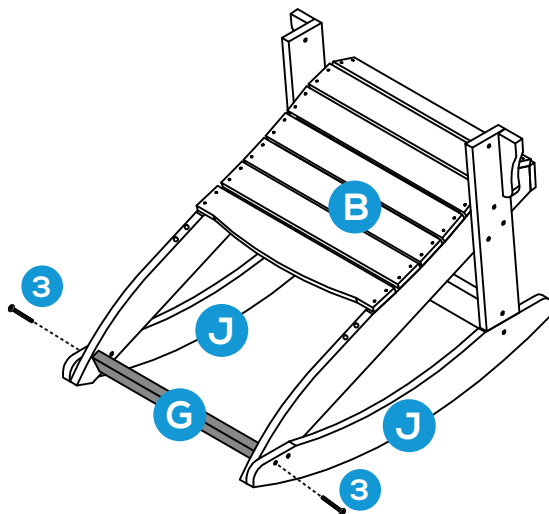

## PRODUCT ASSEMBLY

6

Attach part D Left Chair Arm to part F Left Chair Leg with 1 set of hardware 4 Bolt and hardware 7 Flange Nut.

Do the same to attach part C Right Chair Arm to part E Right Chair Leg.

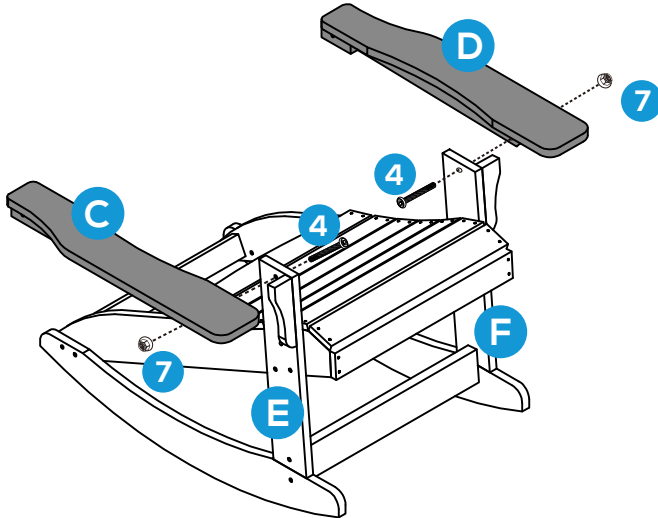

7

Place part A Chair Backrest onto part B Chair Seat as below and attach it to part C Right Chair Arms and part D Left Chair Arms with 2 pcs of hardware 6 Bolt.

Attach part G Rear Brace to part B Chair Seat with 4 pcs of hardware 2 Bolt.

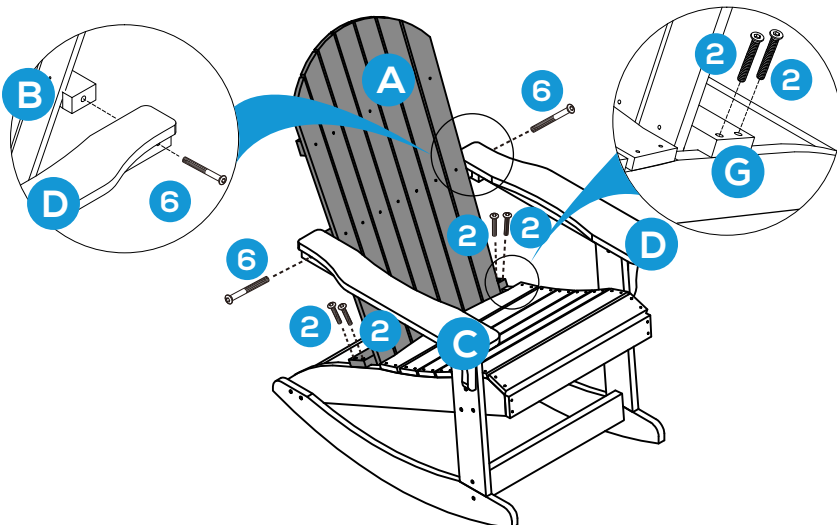

## PRODUCT ASSEMBLY

**8**

Tighten all the bolts again to ensure the steady of this Chair.

The assmebly finishes, enjoy the chair now.

