

This document, including the design, configuration and mechanical features revealed herein are the sole, confidential and proprietary property of TRU Corporation. Reproduction or use thereof, in whole or part, is prohibited without the prior written consent of TRU Corporation.

REV.	DESCRIPTION	DATE	APPROVED
-	ORIGINAL ISSUE	9/18/07	RMK

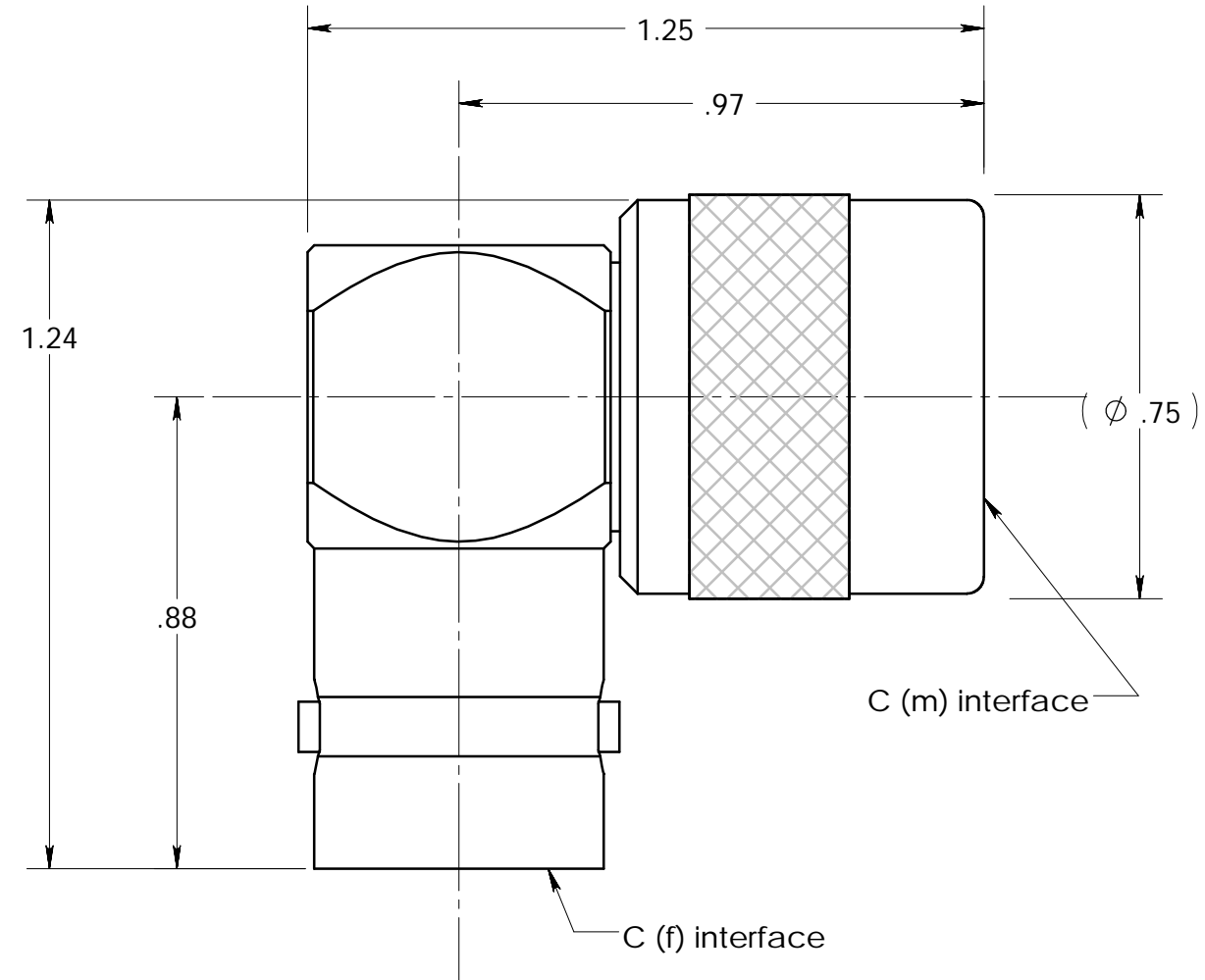
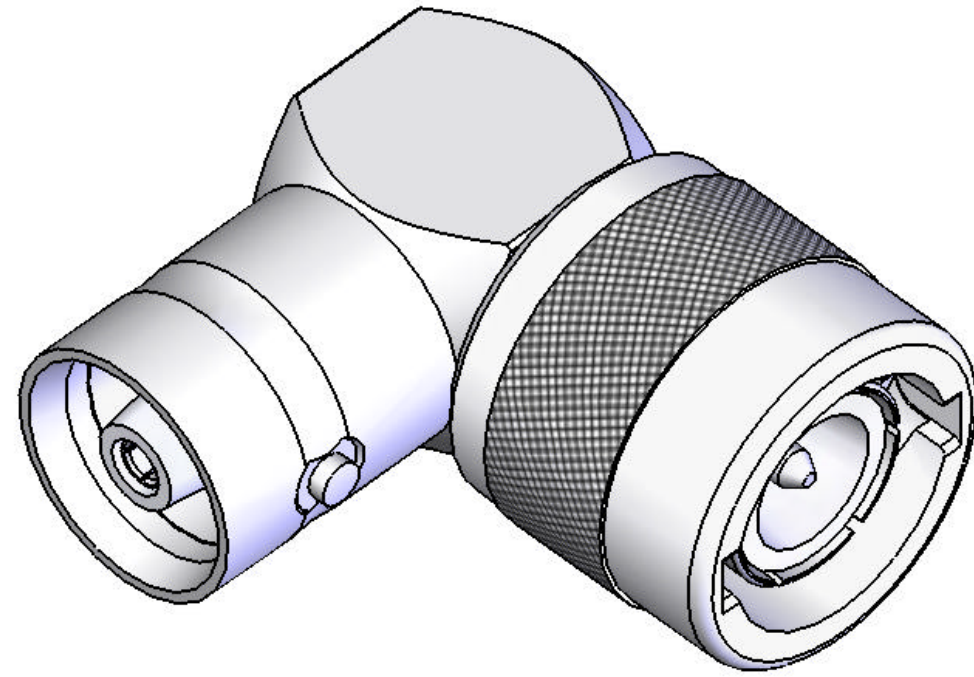

**ENGINEERING DATA:**

**ELECTRICAL:**  
IMPEDANCE: 50 OHMS NOMINAL

**MECHANICAL:**  
INTERFACE: C (m) per MIL-STD-348, fig. 302.1  
C (f) per MIL-STD-348, fig. 302.2

**WEIGHT:** 0.1 POUNDS

**MATERIAL:**  
INSULATORS: PTFE (Teflon) per ASTM-D1710, I1A  
OUTER CONTACT FINGERS: BERYLLIUM COPPER C17300, TD04 per ASTM-B196  
OTHER METAL PARTS: BRASS C36000, H02 per ASTM-B16  
GASKET: SILICONE RUBBER per A-A-59588A, cl. 2A, gr. 50-60

**FINISH:**  
ALL METAL PARTS: SILVER PLATED

**NOTES:**  
1. UNLESS OTHERWISE SPECIFIED; ALL DIMENSIONS ARE REFERENCE ONLY.  
2. PRODUCT COMPLIES WITH RoHS DIRECTIVE 2002/95/EC.

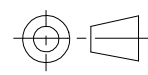
MATERIAL	DO NOT SCALE DRAWING	DRAWN RMK	DATE 9/13/07	 <b>TRU CORPORATION</b> 245 LYNNFIELD STREET, PEABODY, MA 01960 The Custom Interconnect Leader™
	UNLESS OTHERWISE SPECIFIED: DIMENSIONS ARE IN INCHES	ENG APPR. KOCH	DATE 9/18/07	
COMMENTS:	TOLERANCES: FRACTIONS: ±1/64 .XX : ±.01 .XXX: ±.005 ANGLES: ±1/2°	MFG APPR. ----	DATE ----	TITLE: <b>CONNECTOR, COAXIAL, RF C (f-m) ADAPTER, RIGHT ANGLE</b>
	MACHINED SURFACES: <b>63/</b>	OTHER APPR. AM	DATE 9/18/07	
weight: 0.105 lbs	THIRD ANGLE PROJECTION			SIZE <b>B</b> DWG. NO. <b>TRU-15044</b> REV <b>-</b>
		CAGE CODE: 92180	SCALE: 3:1	SHEET 1 OF 1