

### Features

- Digitally controlled thermostatic mixing valve
- For use with DTV+ system
- Antiscald protection
- Six independently controllable 1/2" NPT (13 mm) outlets
- 3/4" NPT inlets
- Maximum flow rate of 21.0 gpm (79.5 lpm) with 10.0 gpm (37.9 lpm) maximum flow from one outlet
- Includes filter screens
- Crossflow prevention
- High-temperature limit setting for additional protection

### Installation

- Suitable for use in either showering and/or bathing applications
- Mounts within standard 2" x 4" (38 x 102 mm) walls
- Includes 110 V AC power supply
- Data cable sold separately

### Required Products/Accessories

K-99693-P Digital interface  
K-99694 Interface Mounting Bracket  
K-99695 System Controller Module

or

K-99693-P Digital interface  
K-99694 Interface Mounting Bracket  
K-99695-E Eco-system controller module

### Recommended Products/Accessories

K-97172 Data cable for K-682-K six-port valve  
K-23723 Faucet cleaner



### Codes/Standards

ASME A112.18.1/CSA B125.1  
ASSE 1016/ASME A112.1016/CSA B125.16  
UL 1951  
CSA C22.2 No. 14  
CSA C22.2 No. 68  
IAPMO Certification

### KOHLER® Electronic Faucets, Valves, and Controls Five-Year Limited Warranty

See website for detailed warranty information.

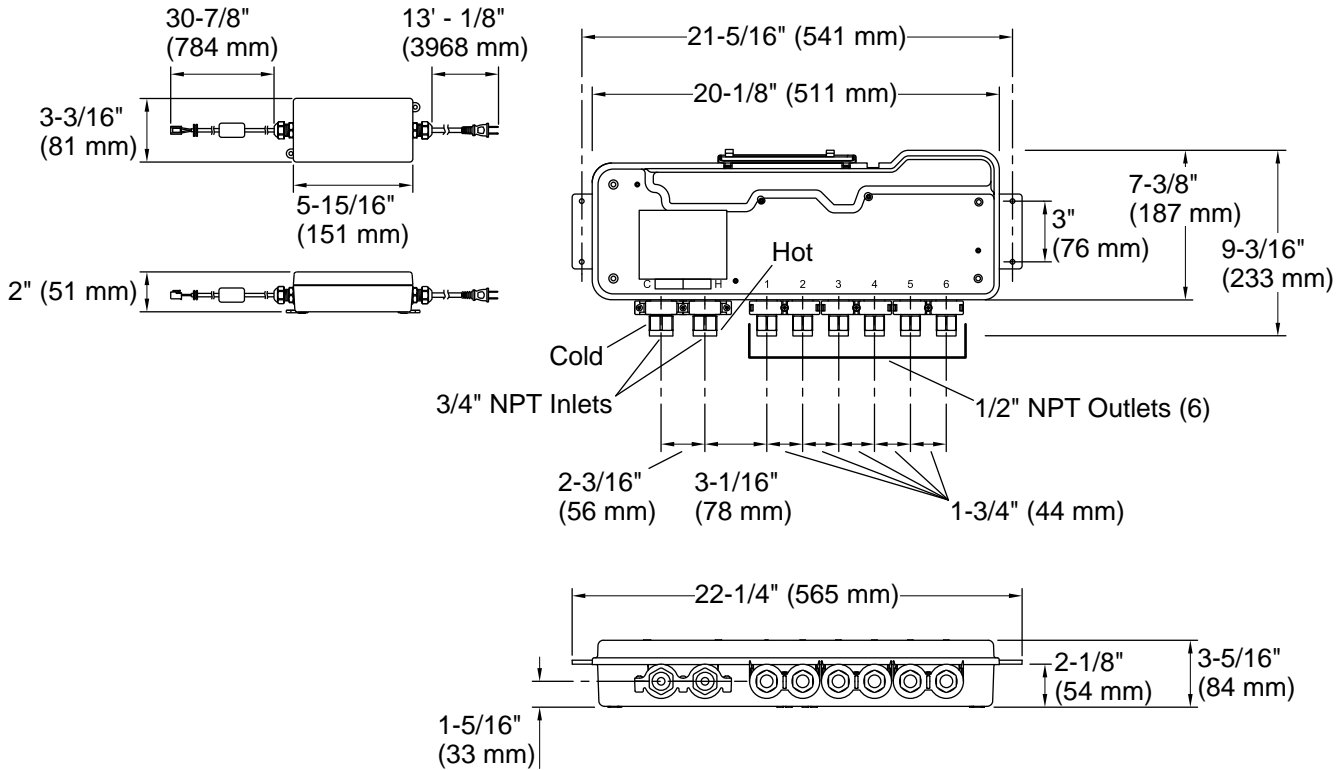

## Technical Information

All product dimensions are nominal.

Electrical component Thermostatic valve: 120/240 V, 1.5 A,  
rating: 50/60 Hz

## Handshower:

Rated maximum flow: 0 gal/min (0 l/min)

## Notes

Install this product according to the installation instructions.

This valve should be used in shower systems only and is not intended to be connected to bath spouts unless installed in a DTV-Bath system.

Provide access for servicing valve.

Use 3/4" supply lines for optimum performance.

A hot water system equal to 80 gallons (102 L) is recommended.

Pressure regulators are strongly recommended in applications where large pressure swings are anticipated or pressure differences between the supplies exist.

Water hammer arrestors and shut-offs are required in both the hot and cold supplies.

Drain requirements: The maximum flow rate of the valve system is 21 gal/min (79.5 l/min) at 45 psi (310.3 kPa). Use a minimum 3" (76 mm) single drain, minimum 2" (51 mm) multiple