

FLEXSTEEL®

W1027-834

ROUND DINING TABLE

IMPORTANT

Carefully remove all parts from the carton, and put them individually on a soft cloth to prevent damage to the parts.

We have taken great care in the design of this product and request that you carefully and accurately follow our assembly instructions to ensure proper set-up.

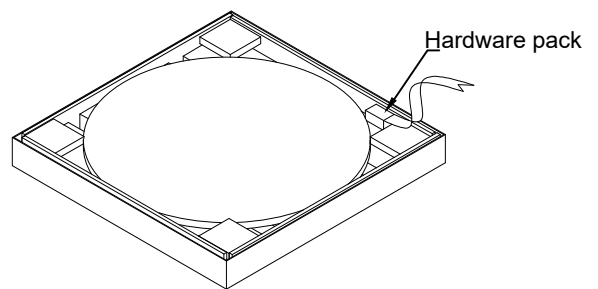
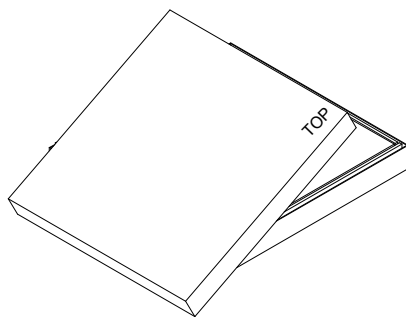
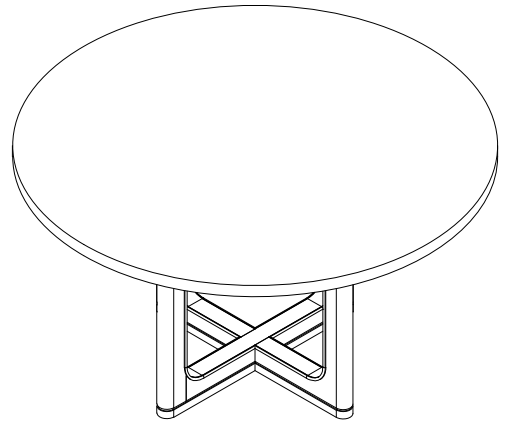

Part List

Assembly Instructions 1/3

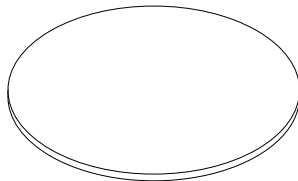

A. Table top
1 piece

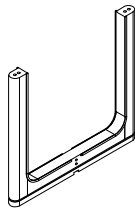

B. U Shaped Leg
1 piece

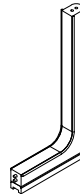

C. L Shaped Leg
2 pieces

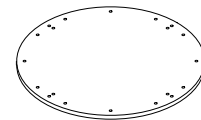

D. Connecting Panel
1 piece

Hardware List

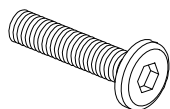

Bolt
Ø5/16"-18 UNC x 1-1/2"
20 pieces



Spring Washer
Ø5/16" x 1.5mm
20 pieces



Flat Washer
Ø5/16" x Ø19mm x 1.5mm
20 pieces

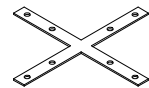

Metal Plate
11-3/4" x 11-3/4" x 1/8"
1 piece

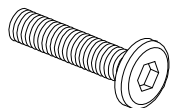

Bolt
Ø1/4"-20 UNC x 3/4"
8 pieces



Spring Washer
Ø1/4" x 1.5mm
8 pieces



Flat Washer
Ø1/4" x Ø19mm x 1.5mm
8 pieces

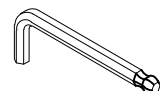

Hex Key
5/32"
1 piece

FLEXSTEEL®

Assembly Instructions 2/3

IMPORTANT NOTES

- Do not tighten up all the bolts until each part is properly assembled.
- Keep the Hex Key in a safe place as you may need to tighten up the bolts in the future.
- Use a soft cloth between these parts and the floor.
- We recommend this product be assembled by at least two adults.

STEP 1

Remove the crossbar on the U shaped Leg (B) by removing the screws with a Phillips screwdriver (not included). (See Figure 1). The crossbar and screws are not needed for assembly, and may be discarded.

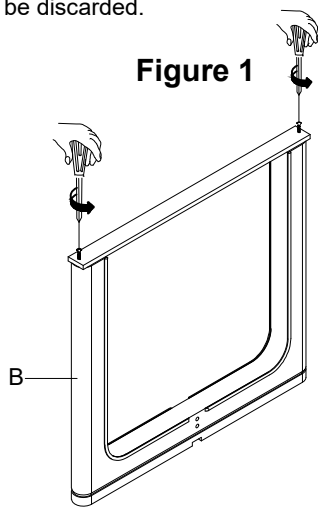

STEP 2

Connect U Shaped Leg (B) and L Shaped Leg (C). (See Figure 2).

Figure 2

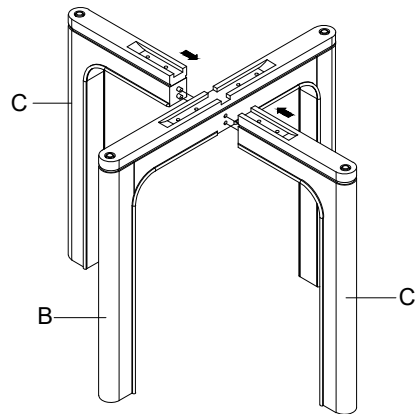

STEP 3

Connect the U Shaped Leg (B) and L Shaped Leg (C) with Metal Plate by inserting Bolt, Spring Washer, Flat Washer and fully tighten with Hex Key. (See Figure 3).

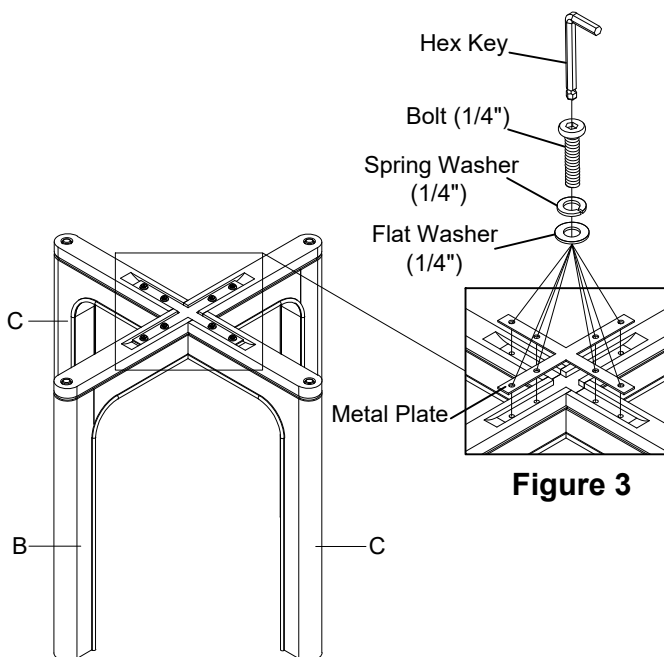

STEP 4

Connect the Connecting Panels (D) to U Shaped Leg (B) and L Shaped Leg (C) by inserting Bolt, Spring Washer, Flat Washer and fully tighten with Hex Key. (See Figure 4).

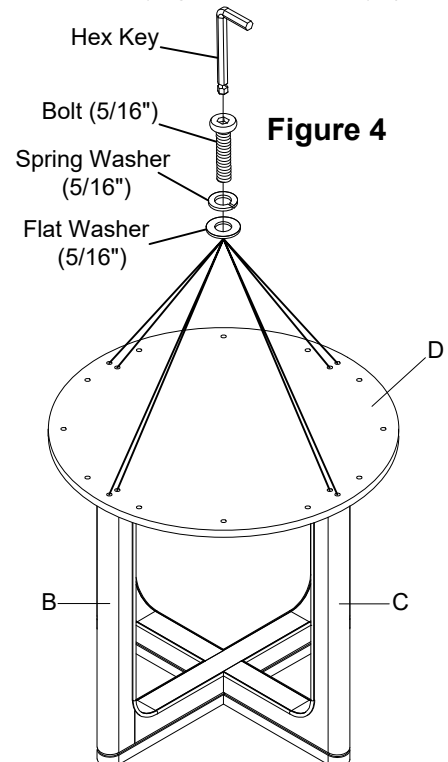

FLEXSTEEL®

Assembly Instructions 3/3

IMPORTANT NOTES

- Do not tighten up all the bolts until each part is properly assembled.
- Keep the Hex Key in a safe place as you may need to tighten up the bolts in the future.
- Use a soft cloth between these parts and the floor.
- We recommend this product be assembled by at least two adults.

STEP 5

Connect the Connecting Panels (D) and Table Top (A) by inserting Bolt, Spring Washer, Flat Washer and fully tighten with Hex Key. (See Figure 5)

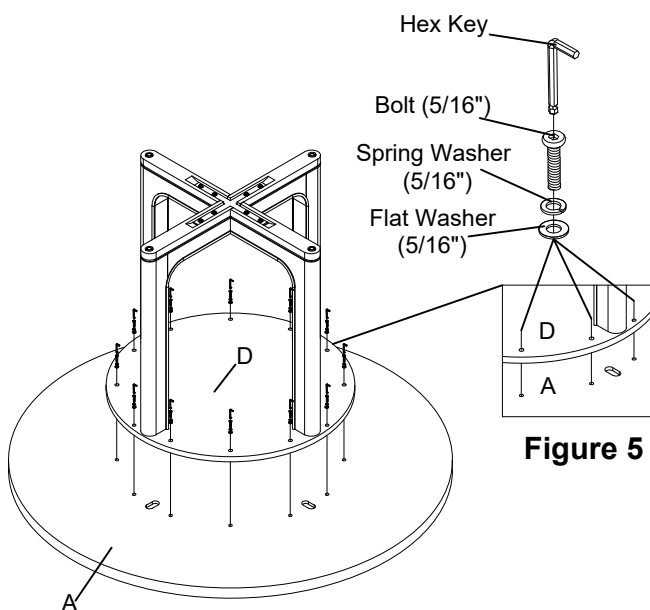

Figure 5

STEP 6

Flip table over, and adjust the levelers on the legs until the furniture is leveled. (See Figure 6)

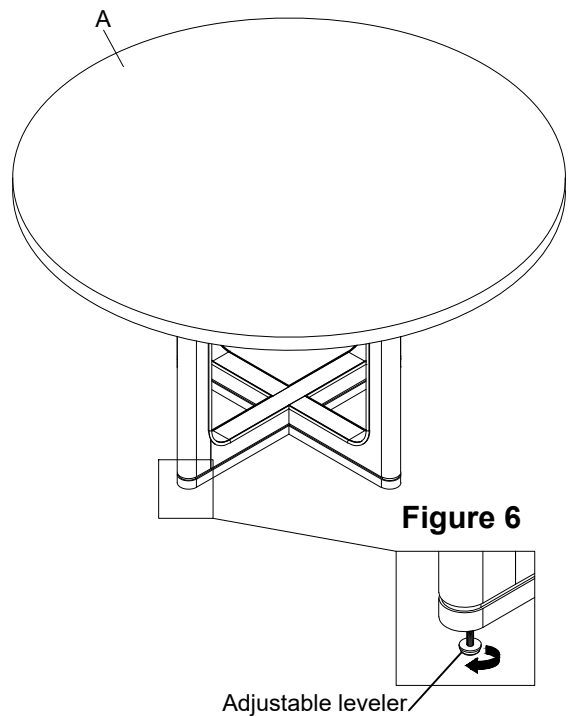

Figure 6

CARE INSTRUCTIONS

- To avoid scratches, do not place sharp or jagged objects directly on the table top.
- Do not place hot items directly on the table top.
- Use placemats or trivets under hot items and coasters under beverages to prevent marks and stains.
- Avoid the use of harsh chemicals or abrasive cleaning materials.
- Wipe the table clean with a soft, dry cloth after each use.
- Wipe up spills quickly with a soft, dry cloth.

Flexsteel Industries, Inc.

For Parts or Customer Service call

toll-free:

1-888-415-3979

Monday-Friday

8:00 a.m. -5:00 p.m.

(Central Time)

Email:

customersolutions@flexsteel.com

www.flexsteel.com