

INSTRUCTION MANUAL

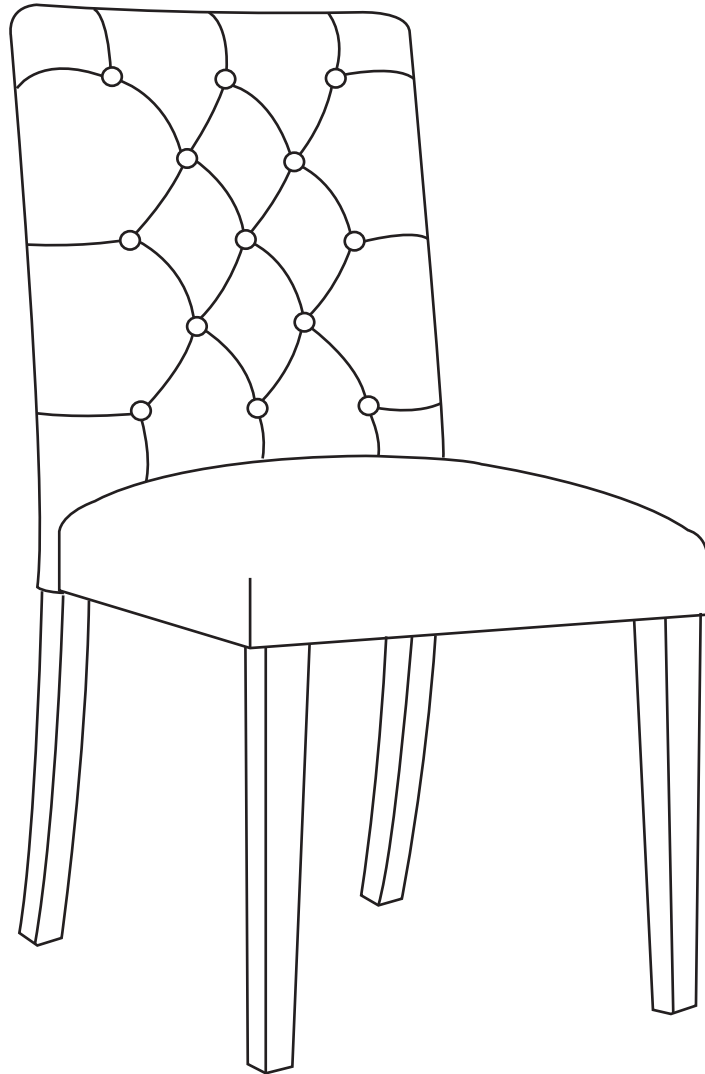

Linen Fabric Tufted Upholstered Side Chair
SKU: ID302

! CARE & MAINTENANCE

- △ Clean the dust with a soft cloth
- △ Do not store in extremely wet environment.

HARDWARE

1 Flat washer



2 Lock washer



3 Allen Key

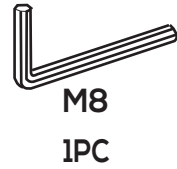

4 Shorter Screw



5 Medium Screws



6 longer Screws

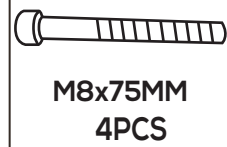

PARTS

A

Back

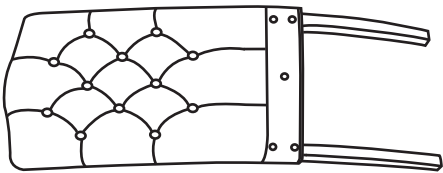

1PC

B

Seat

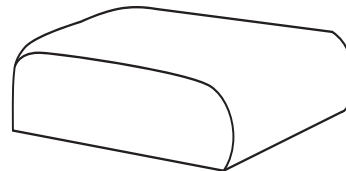

1PC

C

Front Legs

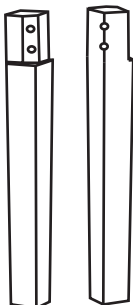

2PCS

PRODUCT ASSEMBLY

1

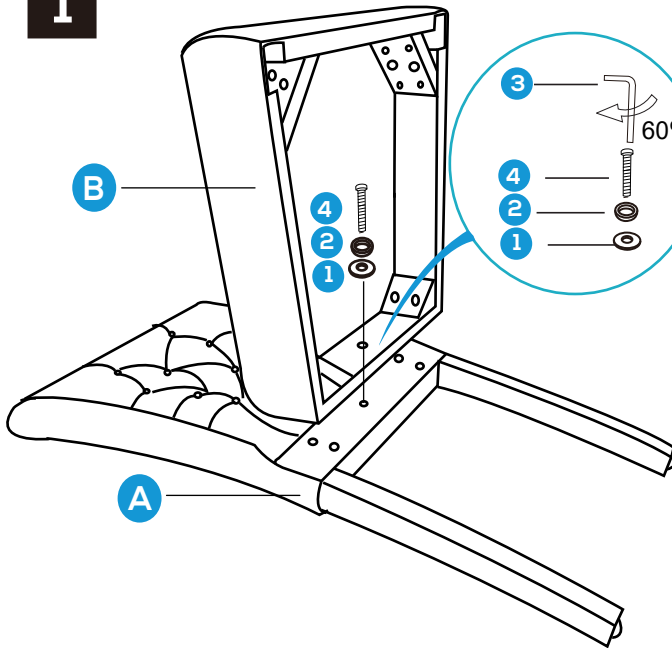

Put chair back on a clean flat surface.

Place seat pad against chair back as shown in diagram.

Secure center holes of the seat pad to chair back by using **SHORTER SCREW (4)** with Washer (#2, 1).

DO NOT FULLY TIGHTEN.

First **HAND** tighten then tightened using key up-to **60-80%** only at this stage.

2

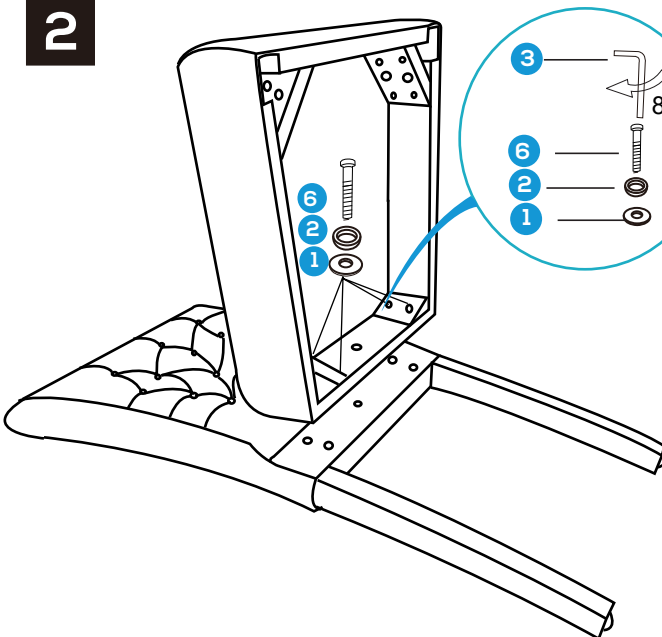

Secure both corner holes of the seat pad to the chair back by using **LONGER SCREWS (6)** with washers (#2, 1).

DO NOT FULLY TIGHTEN. First **HAND** tighten All 4 screws **TOGETHER** at the same time.

Tightened up-to **60-80%** using key only at this stage.

PRODUCT ASSEMBLY

3

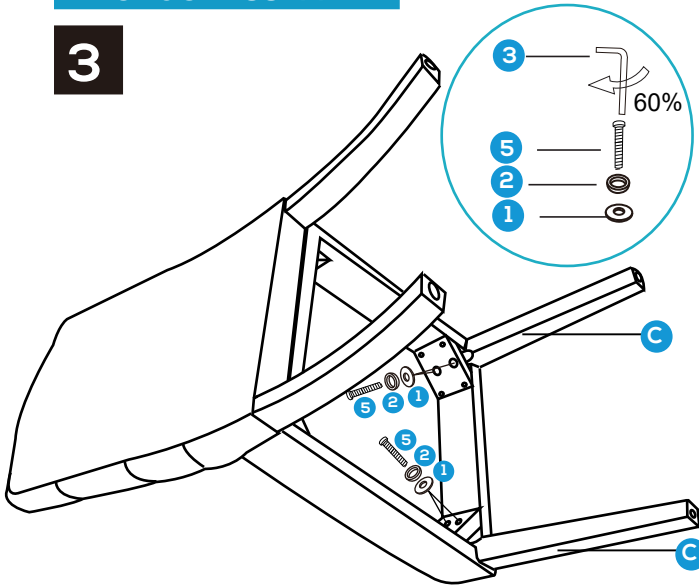

Align front legs in the seat pad as shown in the diagram.

Secure both corner holes of the seat pad to the chair back by using screws MEDIUM SCREWS (5) with washers (#2,1).

DO NOT FULLY TIGHTEN.
First **HAND** tighten All 4 screws **TOGETHER** at the same time.

Tightened up-to 60-80% using key only at this stage.

4

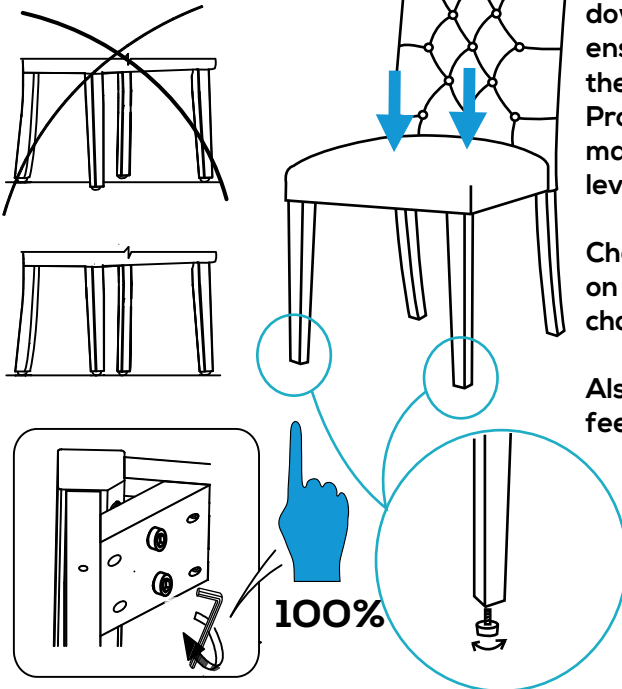

Put chair in the upright position and **SIT ON THE CHAIR** to press downwards on the seat pad ensuring that all 4 feet touch the ground and chair is leveled. Proceed to tighten all screws making sure the chair remains level when tightening.

Check that all screws are tight on a regular basis to ensure chair remains level and secure.

Also you can using adjustable feet to keep four legs level .

PRODUCT ASSEMBLY

5

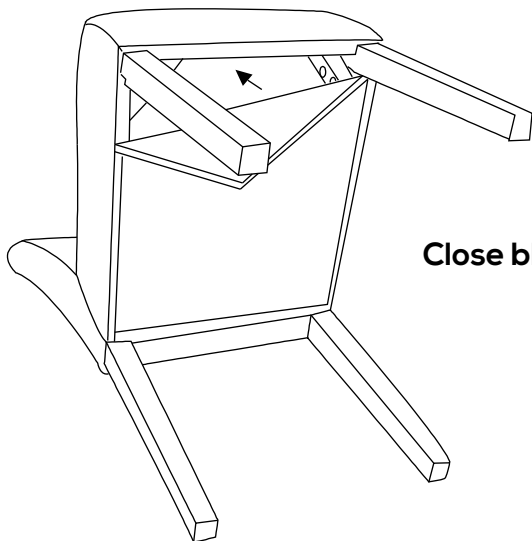

Close black fabric cover

6

