

Wiring

Please take every precaution to wire your DVC woofers for the correct impedance

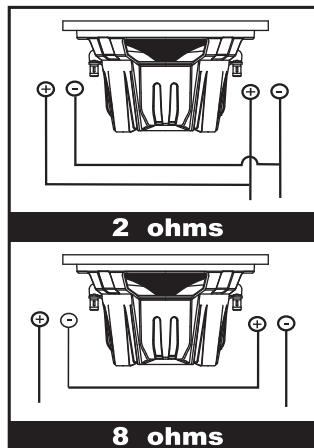

10" (254mm) Subwoofer

(1100 Watts RMS)

- 10" (254mm) ELECTROPLATE INJECTION CONE BUTYL RUBBER SURROUND
- DUAL 2.5" (64mm) HIGH TEMPERATURE ALUMINUM VOICE COIL
- 2200 WATTS PEAK/1100 WATTS RMS
- FREQUENCY RESPONSE: 25Hz-1.5KHz
- SENSITIVITY: 96dB (1WATT/1 METER)
- IMPEDANCE: DUAL 4OHMS
- MOUNTING DEPTH: 5-15/16" (151mm)
- MOUNTING DIAMETER: 8-3/5" (218mm)

User's Manual

10-INCH DUAL VOICE COIL
SUBWOOFER
P108DC

PHANTOM
SERIES

BOSS[®]
AUDIO SYSTEMS

P108DC
10-INCH DUAL VOICE COIL
SUBWOOFER

01.2010



tech support: www.bossaudio.com/support

BOSS Audio Systems
3451 Lunar Court • Oxnard, CA 93030

www.bossaudio.com

800.999.1236

Recommended Enclosures

Please note : Our recommended box volumes are given for internal air requirements.

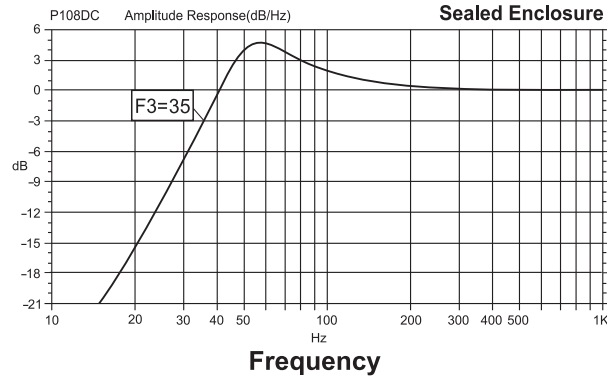

Sealed Enclosure

Box Volume : 0.95 Cu Ft

Box is given as internal air volume including driver displacement

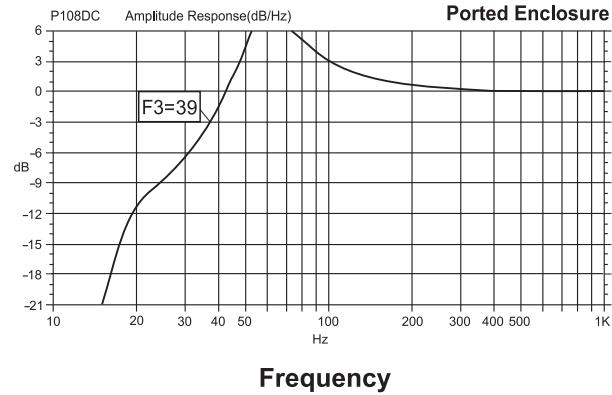
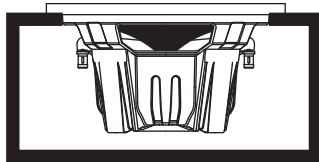

Frequency

Ported Enclosure

Box Volume : 1.12 Cu Ft

Box is given as internal air volume including driver displacement

Port Frequency : 50 Hz
 Port Diameter : 3 Inches
 Port Length : 6 Inches

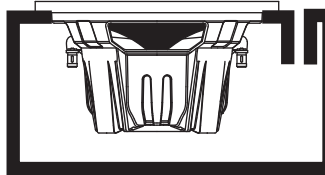

Product Specifications

Speaker Impedance		table	2ohms	4ohms
Free Air Resonance	(Fs)		51	51
Total Q Driver @ FS including all resistance's	(Qts)		0.885	1.336
Q of the Driver @ FS including non electrical resistance only	(Qms)		6.808	5.949
Q of the Driver @ FS including electrical resistance only	(Qes)		1.018	1.722
The Driver's compliance expressed as an equivalent	(Vas)		16.17	40.412
Volume of all (cubic Ft.)				
The Driver's linear displacement (inches)	(Xmax)		0.5	0.5
The DC resistance of the driver's twin voice coils(ohms)	(Re)		1.7	3.4
Thermal Power rating of Driver (Peak / R.M.S.)	(Pe)		2200W/1100W	2200W/1100W
The Driver's sensitivity (dB)	(Sens)		96	96

Calculating Enclosures

It is difficult to give exact box dimensions that are universal for all cars and trucks. It is for this reason that you must be able to calculate the space in which you have available in order to achieve the proper air volume required.

It is recommended to build your enclosure from 3/4" thick MDF (medium density fiberboard). Make sure the enclosure is sealed air tight.

Calculating External Volume

- 1) To calculate box volume, measure the outside Width x Height x Depth of the enclosure. Example 12" x 14" x 9" = 1512"
- 2) Next you must convert cubic inches into cubic feet. To do this, You must divide the cubic inch total by 1728". Example 1512 ÷ 1728= .875 Cubic feet

Calculating Internal Volume

- 1) To calculate the internal (net) volume of the above box you must first multiply the thickness of the wood you are using by Two (2) Example; 3/4" x 2"=1.5"
- 2) Next Subtract 1.5 from each of the outside measurements of the box. Width 12-1.5=10.5 Height 14-1.5=12.5 Depth 9-1.5=7.5
- 3) Multiply the new totals (H x W x D) Example : 10.5 x 12.5 x 7.5=984.375
- 4) Next you must convert cubic inches into cubic feet.To do this,you must divide the cubic inch total by 1728" Example 984.375 ÷ 1728= .5696 Cubic feet